

# ARFEM®

## ALÜMİNYUM

Diyarbakır' dan  
Dünya' ya Üretiyoruz

**GENEL KATALOG**



Arfem inşaat 1988 yılında inşaat, otoyol, alt yapı, baraj, içme suyu göleti, arıtma tesisi ve hidroelektrik tesisi yapımında faaliyet göstermek üzere Diyarbakır'da kurulmuştur.

Türkiye'nin birçok ilinde başarılı işlere imza atan firmamız, bölge pazarında büyük bir pay edinmiştir. Kazandığımız bu başarılar ülkemize ve bölgemize hizmet konusunda firmamıza daha fazla sorumluluk yüklemiş olup, bizi daha fazla yatırım ve istihdama yönlendirmiştir. Bu amaç doğrultusunda "Diyarbakır'dan Dünya'ya Üretiyoruz" sloganı ile alüminyum profili üretmek üzere Arfem Alüminyum 2011 yılında kurularak ülkemiz sanayisine kazandırılmıştır. Firmamızın temel faaliyet alanı; inşaat, mobilya, duşa kabin, cam balkon, perde, küpeşte ve elektronik gibi alanlara alüminyum profil üretimini yapmaktır. Ayrıca müşterilerimizden gelen özel projeler doğrultusunda alüminyum profil üretimi de gerçekleştirmektedir. Faaliyetlerini Türkiye ve Bölge ekonomisi için yatırım, istihdam ve değer yaratma sorumluluğu ile sürdüren firmamız, kurulduğu günden bugüne üretimini ve çalışan sayısını artırarak hızlı gelişimine devam etmektedir. Arfem Alüminyum, 400 personeli ile toplamda 40.000 m<sup>2</sup> açık alan üzerinde, 30.000 m<sup>2</sup> kapalı alanda faaliyet göstermektedir. Firmamız toplamda 2000 ton/ay kapasiteli 1100, 1450, 1450 ve 2200 ton olmak üzere 4 adet ekstrüzyon pres, 1600 ton/ay eloksal ve 600 ton/ay elektrostatik toz boya tesisleri ile üretimini sürdürmektedir.

### Misyon

Sürekli gelişim ve değişim gösteren alüminyum sektöründe; kalite, güven ve müşteri memnuniyeti esasına dayalı felsefemizle, yerli ve yabancı pazarda süreklilik göstermek, söz sahibi ve kalıcı olmak ana hedefimizdir.

### Vizyon

Yenilikçi uygulamalar ile teknolojik gelişmelere ve değişime ayak uydurmak; kalite ve değerlerimizden ödün vermeden yerli, yabancı pazarda en iyi hizmeti sunmak, sektörde saygın bir kuruluş olarak yerini almak.



Arfem Construction was established in Diyarbakir in 1988 to operate in construction, building highways, infrastructures, dams, drinking water ponds, treatment facilities and hydroelectric plants.

Accomplishing successful works in many provinces of Turkey, our company has had a great share for itself in the regional market. These accomplishments have laid a greater burden on our company in terms of serving our country and region and directed us to more investments and employments. Accordingly, Arfem Aluminum was founded in 2011 to produce aluminum profiles with the motto "We Produce in Diyarbakir for the World".

Our company's scope is to produce aluminum profiles for areas such as construction, furniture, shower cabins, glass balconies, curtains, guardrails and electronics. In addition, we produce aluminum profiles in accordance with custom project coming from our customers.

Operating with the responsibility of investment, employment and value creation for the economy of Turkey and the region, our company has continued its rapid growth increasing its production and employee since its foundation. Arfem Aluminum is in service with its 400 employees in an outdoor area of 40,000 m<sup>2</sup> and indoor area of 30,000 m<sup>2</sup>. Our company manufactures 1100, 1450, 1450 and 2200 tons with 4 pieces of extrusion press, 1600 tons/month eloxal and 600 tons/month electrostatic powder coating facilities with a capacity of 2000 tons/month.

### Mission

Continuous improvement and showing changes in the aluminum industry; quality, trust and customer satisfaction based on our philosophy is based on domestic and foreign markets to show continuity, the owner and our main goal is to become permanent.

### Vision

Innovative and deploys technological developments and to adapt to change; native without compromising our quality and value, to provide the best service in the foreign market sector to take its place as a respected organization.



# Üretim Tesisimiz

**ARFEM**<sup>®</sup>  
ALÜMİNYUM

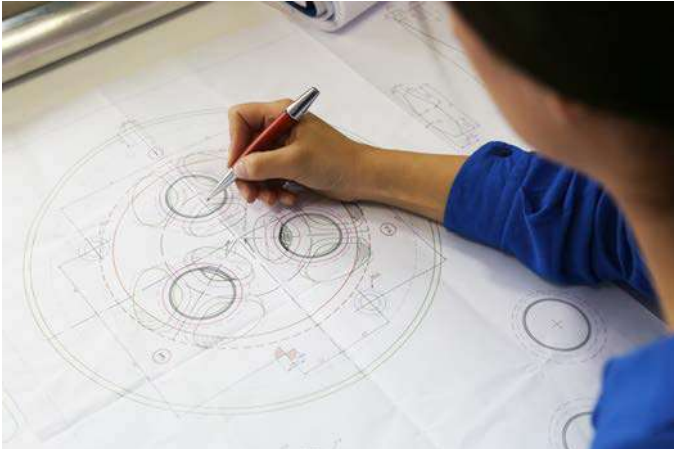

**CE**

**1783**

**ARFEM İNŞ.METAL TAŞ.TİC.SAN.A.Ş**  
Yaytaş Mah. Organize Sanayi 15. Cad. No:7/1  
Yenişehir/DİYARBAKIR

**17**  
**1783 - CPR - 491**

TS EN 15088: 2006

Alüminyumdan Mamül;

Yapısal Profiller, Levhalar, Çubuklar ve Borular

**MEKANİK ÖZELLİKLER:**

Akma Dayanımı(N/mm<sup>2</sup>) Min : 216 N/mm<sup>2</sup>  
Çekme Dayanımı(N/mm<sup>2</sup>) Min : 235,6 N/mm<sup>2</sup>  
Kopma Dayanımı(N/mm<sup>2</sup>) % Min : 13 N/mm<sup>2</sup>  
Sertlik Değeri(HBW) : 84,6

EN AW-6063 T6



Sertifika • Certificate • Zertifikat • Certificat • Сертификат  
Πιστοποιητικό • Certifikatë



**EuroSystem®**

**EuroGap Belgelendirme Kuruluşu**  
**EuroGap Certification Company**

TS ISO 45001 İş Sağlığı ve güvenliği sistemleri  
Occupational health and safety management systems

**Firma Adı**  
Company Name : ARFEM İNŞAAT METAL TAŞIMACILIK TİCARET SANAYİ ANONİM ŞİRKETİ

**Firma Adresi**  
Company Address : ORGANİZE SANAYİ BÖLGESİ 15. CAD. 110 ADA NO:12 YENİŞEHİR / DİYARBAKIR

**Belge Kapsamı**  
Certificate Scope : EKSTRÜZYON İMALAT YÖNTEMİ İLE ALÜMİNYUM PROFİL ÜRETİMİ, ELEKSAL KAPLAMA, TOZ BOYA VE DESEN KAPLAMA, DEKORATİF PANEL ÜRETİMİ, DÖKÜM İMALAT YÖNTEMİ İLE ALÜMİNYUM BİLETT ÜRETİMİ

**Sertifika No**  
Certificate Number : ISGS220046000

**İlk Belgelendirme**  
First Certification : 18.11.2020

**1. Gözetim Tarihi**  
1. First custody Date : 18.11.2021

**2. Gözetim Tarihi**  
2. First custody Date : 18.11.2022

**Belge Süresi**  
Certification Duration : 3 YIL

**Belge Bitiş Süresi**  
Certification Ends Duration : 18.11.2021

Bu sertifika, TS ISO 45001 - İş Sağlığı ve Güvenliği Sistemleri Standardı'na uygunluğunu belgelendirmek amacıyla, yukarıda tanımlanan faaliyetleri kapsamında verilmiştir. "EuroGap Uluslararası Standartı Sertifikasyon Enstitüsü Limited Şirketi" tarafından hazırlanmış ve onaylanmıştır.

ENİSOĞAK ULUSLARARASI STANDART SERTİFİKASYON ENSTİTÜSÜ LİMİTED ŞİRKETİ / ENİSOĞAK INTERNATIONAL STANDARDS CERTIFICATION INSTITUTE CO.LTD.  
Kocayolu Cad. Başkent Plaza, 01040. Beşiktaş / İstanbul / Türkiye  
Ticaret Sicil No: 412 228 21 52 54 Faks/Tele: +90 412 228 21 52 Web: www.enisoqak.com.tr E-mail: info@enisoqak.com.tr  
Ticaret Sicil No: 1589 / SK. Yenimahalle İlçe. No: 23 Melikgazi Cad. / Ankara / Türkiye  
Ticaret Sicil No: 199 242 213 44 68 Faks/Tele: +90 312 213 44 68 Web: www.enisoqak.com.tr E-mail: info@enisoqak.com.tr  
- Bu belge, ENİSOĞAK tarafından belirlenen diğer belgelerin bir parçasıdır ve diğer belgelerle birlikte değerlendirilmelidir.  
- This Certificate is valid as long as the customer acts in accordance with Certification Rules and Contract Conditions prepared by EuroGap  
- Vous pouvez vérifier votre certification en sur notre page: www.enisoqak.com.tr

FR-026-Brev. No 00-18112019



Sertifika • Certificate • Zertifikat • Certificat • Сертификат  
πιστοποιητικό • certifikatë



**EuroGap Belgelendirme Kuruluşu**  
**EuroGap Certification Company**

**TS EN ISO 14001 Çevre Yönetim Sistemi Belgesi**  
**TS EN ISO 14001 Environmental Management System Certification**

**Firma Adı**  
**Company Name**

: ARFEM İNŞAAT METAL TAŞIMACILIK TİCARET SANAYİ ANONİM ŞİRKETİ

**Firma Adresi**  
**Company Address**

: ORGANİZE SANAYİ BÖLGESİ 15. CAD. 110 ADA NO:12 YENİŞEHİR / DİYARBAKIR

**Belge Kapsamı**  
**Certificate Scope**

: EKSTRÜZYON İMALAT YÖNTEMİ İLE ALÜMİNYUM PROFİL ÜRETİMİ, ELOKSAL KAPLAMA, TOZ BOYA VE DESEN  
KAPLAMA, DEKORATİF PANEL ÜRETİMİ, DOKÜM İMALAT YÖNTEMİ İLE ALÜMİNYUM BİLETT ÜRETİMİ

**Sertifika No**  
**Certificate Number**

: CYS5220029300

**İlk Belgelendirme**  
**First Certification**

: 18.11.2020

**1. Gözetim Tarihi**  
**1. First custody Date**

: 18.11.2021

**2. Gözetim Tarihi**  
**2. First custody Date**

: 18.11.2022

**Belge Süresi**  
**Certification Duration**

: 3 YIL

**Belge Bitiş Süresi**  
**Certification Ends Duration**

: 18.11.2021

Bu sertifika, TS EN ISO 14001:2015 Çevre Yönetim Sistemi Standardı'na uygunluğunu belgelemek amacıyla, yukarıda tanımlanan faaliyetler kapsamında verilmiştir. EUROGAP ULUSLARARASI STANDART SERTİFİKASYON ENSTİTÜSÜ LİMİTED ŞİRKETİ tarafından hazırlanmış ve onaylanmıştır.



ΕΠΙΣΚΟΠΗ ΠΕΡΙΣΤΑΤΕΙΑΣ ΣΤΑΘΜΟΥ ΣΕΡΤΙΦΙΚΑΤΟΥ ΚΑΤΙΠΠΟΥ ΔΙΑΠΤΕΡΕ ΔΙΑΚΟΤΗ / ΕΡΓΟΝΟΜΕΣ ΕΠΙΧΕΙΡΗΣΕΙΣ ΣΤΑΘΜΟΥ ΣΕΡΤΙΦΙΚΑΤΟΥ ΚΑΤΙΠΠΟΥ 001110.  
Μεταφρασμένη: Πόλη της Κωνσταντινούπολης, Οδός Βασιλείας 222, 8. Μακρής / ΕΡΓΟΝΟΜΕΣ ΕΠΙΧΕΙΡΗΣΕΙΣ ΣΤΑΘΜΟΥ ΣΕΡΤΙΦΙΚΑΤΟΥ ΚΑΤΙΠΠΟΥ 001110.  
Türkiye/Prövine: 795 242 221 22 54-54. Pöble/Prövine: 795 242 221 22 54-54. Adres: www.eurogap.com.tr / E-mail: info@eurogap.com.tr  
Türkiye/Konstantinopolis: Söğütören Yolu, 15031/08, Tophane Sok. No:792 İşbirlikçi Evi/Çarşı/001110  
Türkiye/Prövine: 795 242 221 22 54-54. Pöble/Prövine: 795 242 221 22 54-54. Adres: www.eurogap.com.tr / E-mail: info@eurogap.com.tr  
• Bu sertifika, örgütlemenin, kuruluşun faaliyetleri alan belgelendirme sürecinde ve belgelendirme sürecinde gerçekleştirilen faaliyetlerin doğruluğunu belgelemek amacıyla hazırlanmıştır.  
• This Certificate is valid as long as the customer acts in accordance with Certification Rules and Conditions. Certificate prepared by EuroGap.  
• This can verify the certificate on our web page: [www.eurogap.com.tr](http://www.eurogap.com.tr)

Pöble/Prövine: No:01.18.11.2019





Sertifika • Certificate • Zertifikat • Certificat • Сертификат  
πιστοποιητικό • certifikatë



## EuroGAP Belgelendirme Kuruluşu EuroGAP Certification Company

### TS EN ISO 9001 Kalite Yönetim Sistemi Belgesi TS EN ISO 9001 Quality Management System Certification

**Firma Adı**  
Company Name  
: ARFEM İNŞAAT METAL TAŞIMACILIK TİCARET SANAYİ ANONİM ŞİRKETİ

**Firma Adresi**  
Company Address  
: ORGANİZE SANAYİ BÖLGESİ 15. CAD. 110 ADA NO:12 YENİŞEHİR / DİYARBAKIR

**Belge Kapsamı**  
Certificate Scope  
: EKSTRUZYON İMALAT YÖNTEMİ İLE ALÜMİNYUM PROFİL ÜRETİMİ, ELEKSAL KAPLAMA, TOZ BOYA VE DESEN KAPLAMA,  
: DEKORATİF PANELE ÜRETİMİ, DÖKÜM İMALAT YÖNTEMİ İLE ALÜMİNYUM BİLETT ÜRETİMİ

**EA**  
: 17

**Sertifika No**  
Certificate Number  
: KYSS220039200

**İlk Belgelendirme**  
First Certification  
: 18.11.2020

**1. Gözetim Tarihi**  
1. First custody Date  
: 18.11.2021

**2. Gözetim Tarihi**  
2. First custody Date  
: 18.11.2022

**Belge Süresi**  
Certification Duration  
: 3 YIL

**Belge Bitiş Süresi**  
Certification Ends Duration  
: 18.11.2021

**Revizyon No/Tarih**  
Revision Number/ Date  
: 00 / --

İbu sertifika, TS EN ISO 9001:2015 Kalite Yönetim Sistemi Standardı'na uygunluğunu belgelemek üzere, yukarıda tanımlanan faaliyetleri kapsamında verilmiştir.  
EUROGAP ULUSLARARASI STANDART SERTİFİKASYON ENSTİTÜSÜ DİKKETİNDEN HAZIRLANMIŞ VE ONAYLANMIŞTIR.  
This Certificate has prepared and approved by EUROGAP INTERNATIONAL STANDARDS CERTIFICATION INSTITUTE CO.LTD.



TÜRKAK BDS NO  
YS-800C-C12F  
TR.056-Ren. No.02-18112019

İSTİSNAYI KULLANILAN ÜRÜNLERİN SERTİFİKASYON ENSTİTÜSÜ LİSTESİ (SİRKETİ) / İSTİSNAYI KULLANILAN ÜRÜNLERİN SERTİFİKASYON ENSTİTÜSÜ LİSTESİ  
Mükerrer/Center : Bağcıler Mah. 514. Sok. 3. Kat Kat: 277 B. Bağcıler/Şişli/Beşiktaş / İstanbul  
Ticaret/Phone : +90 412 228 21 51-54 Faks/Fax : +90 412 228 21 53 Web : www.eurogap.com.tr E-mail : info@eurogap.com.tr  
Ticaret/Phone : +90 412 228 21 51-54 Faks/Fax : +90 412 228 21 53 Web : www.eurogap.com.tr E-mail : info@eurogap.com.tr  
Ticaret/Phone : +90 242 318 84 00 Faks/Fax : +90 242 318 84 01 Web : www.eurogap.com.tr E-mail : info@eurogap.com.tr  
- Bu sertifika, organizasyon, üretilen ürünler ve hizmetlerin belirlenen ve belirlenen şartlara uygunluğunu göstermektedir.  
- This Certificate is valid as long as the customer acts in accordance with Certification Rules and Certified Conditions prepared by EuroGap.  
- This certificate is valid as long as the customer acts in accordance with Certification Rules and Certified Conditions prepared by EuroGap.



Onaylıdır  
Approved By



**TÜRK STANDARDLARI ENSTİTÜSÜ**  
TÜRK STANDARDLARINA UYGUNLUK BELGESİ  
**TURKISH STANDARDS INSTITUTION**  
CERTIFICATE OF CONFORMITY TO TURKISH STANDARDS



<b>BELGE NUMARASI</b> REFERENCE NUMBER OF LICENCE	099186-TSE-01/04
<b>BELGENİN İLK VERİLİŞ TARİHİ</b> DATE OF FIRST ISSUE OF LICENCE	14.03.2014
<b>BELGENİN SON GEÇERLİLİK TARİHİ</b> LICENCE VALID UNTIL	14.03.2022
<b>BELGE SAHİBİ KURULUŞUN ADI</b> NAME OF THE LICENCE HOLDER	ARFEM İNŞAAT METAL TAŞIMACILIK TİCARET SANAYİ ANONİM ŞİRKETİ
<b>BELGE SAHİBİ KURULUŞUN ADRESİ</b> ADDRESS OF THE LICENCE HOLDER	ORG.SAN.BÖL.15 CADDE 110 ADA NO:12 DİYARBAKIR/TÜRKİYE
<b>ÜRETİM YERİ ADI</b> NAME OF THE MANUFACTURING PLACE	ARFEM İNŞ.MET.TAŞ.TİC.SAN.A.Ş.
<b>ÜRETİM YERİ ADRESİ</b> ADDRESS OF THE MANUFACTURING PLACE	OSB 15 CAD.110 ADA NO:12 DİYARBAKIR / TÜRKİYE
<b>İPTAL EDİLEN BELGE NUMARASI (Varsa)</b> INDICATION OF SUPERSEDED LICENCE (if any)	099186-TSE-01/03
<b>TESCİLLİ TİCARİ MARKASI</b> REGISTERED TRADE MARK	arfem
<b>İLGİLİ TÜRK STANDARDI</b> RELATED TURKISH STANDARD	TS EN 755-1:2016 / 09.12.2016
<b>BELGE KAPSAMI</b> SCOPE OF LICENCE	

\*ALÜMİNYUM VE ALÜMİNYUM ALAŞIMLARI  
EKSTRÜZYONLA İMAL EDİLMİŞ LUMBOZ BORULAR, PROFİLLER - EN AW6063 ALAŞIMDAN İMAL EDİLMİŞ

*e-imzalı/e-signed*

10.03.2021

Belgelendirme Merkezi Başkanı Adına  
MEHMET GENÇ

DİYARBAKIR BELGELENDİRME MÜDÜRÜ

\*Bu belge, belgelendirilen ürünün, üretim yerinin Enstitümüzün belirlediği şartları karşıladığını da gösterir.

\*Bu belge, hiç bir suretle tahrif edilemez, kısmen veya okunmasını zorlaştıracak şekilde çoğaltılamaz, kazıntı ve silinti yapılamaz.

\*TSE DİYARBAKIR BELGELENDİRME MÜDÜRLÜĞÜ \* Adres: Yenişehir Mahallesi Dr. Yusuf Azizoglu Cad. Diyarbakir Ticaret ve Sanayi Odası Eğitim Merkezi No:21 Yenişehir/Diyarbakir

\* Telefon: 0 412 228 92 66\* Faks: 0 412 228 29 31

\*TSE BELGELENDİRME MERKEZ BAŞKANLIĞI; Adres: Necatibey Cad. No:112 06100 Bakanlıklar/ANKARA – Telefon: 0 312 416 64 81 / 416 64 27, Faks:0 312 416 66 17 E-posta :bmb@tse.org.tr , web : www.tse.org.tr







<b>BELGE NUMARASI</b> REFERENCE NUMBER OF LICENCE	099186-TSE-04/01
<b>BELGENİN İLK VERİLİŞ TARİHİ</b> DATE OF FIRST ISSUE OF LICENCE	14.03.2014
<b>BELGENİN SON GEÇERLİLİK TARİHİ</b> LICENCE VALID UNTIL	14.03.2022
<b>BELGE SAHİBİ KURULUŞUN ADI</b> NAME OF THE LICENCE HOLDER	ARFEM İNŞAAT METAL TAŞIMACILIK TİCARET SANAYİ ANONİM ŞİRKETİ
<b>BELGE SAHİBİ KURULUŞUN ADRESİ</b> ADDRESS OF THE LICENCE HOLDER	ORG.SAN.BÖL.15 CADDE 110 ADA NO:12 DIYARBAKIR/TÜRKİYE
<b>ÜRETİM YERİ ADI</b> NAME OF THE MANUFACTURING PLACE	ARFEM İNŞ.MET.TAŞ.TİC.SAN.A.Ş.
<b>ÜRETİM YERİ ADRESİ</b> ADDRESS OF THE MANUFACTURING PLACE	OSB 15 CAD.110 ADA NO:12 DIYARBAKIR / TÜRKİYE
<b>İPTAL EDİLEN BELGE NUMARASI (Varsa)</b> INDICATION OF SUPERSEDED LICENCE (if any)	14.0.30.4.44.00/TSE-64029
<b>TESCİLLİ TİCARİ MARKASI</b> REGISTERED TRADE MARK	ARFEM
<b>İLGİLİ TÜRK STANDARDI</b> RELATED TURKISH STANDARD	TS EN 12020-1 / 02.03.2010
<b>BELGE KAPSAMI</b> SCOPE OF LICENCE	***** ALÜMİNYUM VE ALÜMİNYUM VE ALAŞIMLARINDAN EKSTRÜZYON İLE İMAL EDİLMİŞ HASSAS PROFİLLER ; - ENA W 6060 ve ENAW 6063 ALAŞIMLI ALÜMİNYUM MALZEMEDEN ISIL BARIYERLİ VE ISIL BARIYERSİZ EKSTRÜZYON PROFİLLER

*e-imzalı/e-signed*

10.03.2021

Belgelendirme Merkezi Başkanı Adına  
MEHMET GENÇ

DIYARBAKIR BELGELENDİRME MÜDÜRÜ

\*Bu belge, belgelendirilen ürünün, üretim yerinin Enstitümüzün belirlediği şartları karşıladığını da gösterir.  
\*Bu belge, hiç bir surette tahrif edilemez, kısmen veya okunmasını zorlaştıracak şekilde çoğaltılamaz, kopyasını ve silinti yapılamaz.  
\*TSE DIYARBAKIR BELGELENDİRME MÜDÜRLÜĞÜ \* Adres: Yenişehir Mahallesi Dr. Yusuf Azizoglu Cad. Diyarbakır Ticaret ve Sanayi Odası Eğitim Merkezi No: 21 Yenişehir/Diyarbakır  
\* Telefon: 0 412 228 92 66\* Faks: 0 412 228 29 31  
\*TSE BELGELENDİRME MERKEZ BAŞKANLIĞI; Adres: Necatibey Cad. No:112 06100 Bakanlıklar/ANKARA – Telefon: 0 312 416 64 81 / 416 64 27, Faks:0 312 416 66 17 E-posta : bmb@tse.org.tr , web : www.tse.org.tr

<https://evrakkontrol.tse.org.tr/BelgeDogrulama.aspx?p=0ocqo0ir> adresinden belgenin doğruluğunu ve geçerliliğini sorgulayınız.



1 / 1



**TÜRK STANDARDLARI ENSTİTÜSÜ**  
**TÜRK STANDARDLARINA UYGUNLUK BELGESİ**  
**TURKISH STANDARDS INSTITUTION**  
**CERTIFICATE OF CONFORMITY TO TURKISH STANDARDS**



<b>BELGE NUMARASI</b> REFERENCE NUMBER OF LICENCE	099186-TSE-02/01
<b>BELGENİN İLK VERİLİŞ TARİHİ</b> DATE OF FIRST ISSUE OF LICENCE	14.03.2014
<b>BELGENİN SON GEÇERLİLİK TARİHİ</b> LICENCE VALID UNTIL	19.03.2022
<b>BELGE SAHİBİ KURULUŞUN ADI</b> NAME OF THE LICENCE HOLDER	ARFEM İNŞAAT METAL TAŞIMACILIK TİCARET SANAYİ ANONİM ŞİRKETİ
<b>BELGE SAHİBİ KURULUŞUN ADRESİ</b> ADDRESS OF THE LICENCE HOLDER	ORG.SAN.BÖL.15 CADDE 110 ADA NO:12 DİYARBAKIR/TÜRKİYE
<b>ÜRETİM YERİ ADI</b> NAME OF THE MANUFACTURING PLACE	ARFEM İNŞ.MET.TAŞ.TİC.SAN.A.Ş.
<b>ÜRETİM YERİ ADRESİ</b> ADDRESS OF THE MANUFACTURING PLACE	OSB 15 CAD.110 ADA NO:12 DİYARBAKIR / TÜRKİYE
<b>İPTAL EDİLEN BELGE NUMARASI (Varsa)</b> INDICATION OF SUPERSEDED LICENCE (if any)	14.0.30.4.44.00/TSE-64027
<b>TESCİLLİ TİCARİ MARKASI</b> REGISTERED TRADE MARK	ARFEM
<b>İLGİLİ TÜRK STANDARDI</b> RELATED TURKISH STANDARD	TS 4922 / 15.01.2018
<b>BELGE KAPSAMI</b> SCOPE OF LICENCE	

\*\*ALÜMİNYUM VEYA ALÜMİNYUM ALAŞIMLARININ ANODİK OKSİDASYON İŞLEMİ İLE KAPLANMASI, KAPLAMA KALINLIĞI: AA 10, KİMYASAL MATLAŞTIRMA ÖNİŞLEMİ TATBİK EDİLMİŞ (B), PARLATMA ÖNİŞLEMİ TATBİK EDİLMİŞ (B) (KAPSM GENİŞLEME TARİHİ:26.02.2019)

*e-imzalı/e-signed*

10.03.2021

Belgelendirme Merkezi Başkanı Adına  
MEHMET GENÇ

DİYARBAKIR BELGELENDİRME MÜDÜRÜ

\*Bu belge, belgelendirilen ürünün, üretim yerinin Enstitümüzün belirlediği şartları karşıladığını da gösterir.

\*Bu belge, hiç bir suretle tahrif edilemez, kısmen veya okunmasını zorlaştıracak şekilde çoğaltılamaz, kazıntı ve silinti yapılamaz.

\*TSE DİYARBAKIR BELGELENDİRME MÜDÜRLÜĞÜ \* Adres: Yenişehir Mahallesi Dr. Yusuf Azizoglu Cad. Diyarbakir Ticaret ve Sanayi Odası Eğitim Merkezi No:21 Yenişehir/Diyarbakir

\* Telefon: 0 412 228 92 66\* Faks: 0 412 228 29 31

\*TSE BELGELENDİRME MERKEZ BAŞKANLIĞI; Adres: Necatibey Cad. No:112 06100 Bakanlıklar/ANKARA – Telefon: 0 312 416 64 81 / 416 64 27, Faks:0 312 416 66 17 E-posta

:bmb@tse.org.tr , web : www.tse.org.tr

<https://evrakkontrol.tse.org.tr/BelgeDogrulama.aspx?p=r2rtb4ne> adresinden belgenin doğruluğunu ve geçerliliğini sorgulayınız.



1 / 1





T.C.  
TÜRK PATENT ve MARKA KURUMU

## MARKA YENİLEME BELGESİ

Marka No : 2010 57833 - Ticaret - Hizmet

**ARFEM**

Marka Sahibi : ARFEM İNŞAAT METAL TAŞIMACILIK TIC.SAN. A.Ş.  
TÜRKİYE CUMHURİYETİ  
Organize San.Böl. 15 Cad.110 Ada No:10/B Diyarbakır

Emtiası : 06 , 09 , 17 , 35 , 40  
İlişiktir.

İşbu Marka ilk defa 13/12/2010 tarihinde tescil edilmiş olup, 13/12/2020 tarihinden itibaren ON YIL süreyle yenilenmiştir.



*H.P. Asan*

Prof. Dr. Habip ASAN  
Türk Patent ve Marka  
Kurumu Başkanı

**TURK  
PATENT**  
TÜRK PATENT VE MARKA KURUMU

## Authorization to use the quality sign



This is to certify that

### **ARFEM Insaat Metal Tasimacilik Ticaret Sanayi A.Ş.**

Organize Sanayi Bölgesi 15. Cadde 110 Ada No:12  
TR – 21100 Yenisehir - Diyarbakir

**Licence number: 1650**

is authorized to use the quality sign which is shown above, according to the regulations for the use of the quality label for ARCHITECTURAL ANODIZING as described in the current edition of the Specifications for the QUALANOD quality label for sulfuric acid-based anodizing of aluminium (Edition 01.01.2021). Architectural anodizing is one of the four types of anodizing covered by the Specifications.

**Date of issue of the licence:**

**09.12.2019**

**Period of validity of the licence:**

**until 31.12.2021**

Zurich, 20 November 2020

**QUALANOD**

Dr. Metin Yilmaz  
President

**CERTIFICATION BODY**

Monica Gerber  
General Secretary



Website: [www.qualanod.net](http://www.qualanod.net)

E-Mail: [info@qualanod.net](mailto:info@qualanod.net) // Phone: +41 (0)43 305 09 77 / 81

Mailing address:  
QUALANOD, P.O. Box, CH-8027 Zurich

Domicile:  
QUALANOD  
c/o ARCO Association Management AG  
(certification body)  
Tödistrasse 42, CH-8002 Zurich





**TÜRK STANDARDLARI ENSTİTÜSÜ**  
TURKISH STANDARDS INSTITUTION

## FABRİKA ÜRETİM KONTROLÜ UYGUNLUK BELGESİ 1783-CPR-491

Avrupa Parlamentosu ve Konseyi'nin 9 Mart 2011 tarih ve 305/2011/EU sayılı Tüzüğü (Yapı Malzemeleri Tüzüğü veya CPR) uyarınca, bu belge aşağıda belirtilen yapı malzemesine uygulanır.

**ALÜMİNYUMDAN MAMÜL;  
YAPISAL PROFİLLER, LEVHALAR, BORULAR VE ÇUBUKLAR  
EN AW 6063'den imal edilmiş**

**ARFEM İNŞAAT METAL TAŞIMACILIK TİCARET SANAYİ ANONİM ŞİRKETİ  
ORG.SAN.BÖL.15 CADDE 110 ADA NO:12-DİYARBAKIR/TÜRKİYE**

adı veya tescilli markası altında piyasaya sunulan

**ARFEM İNŞAAT METAL TAŞIMACILIK TİCARET SANAYİ ANONİM ŞİRKETİ  
ORG.SAN.BÖL.15 CADDE 110 ADA NO:12-DİYARBAKIR/TÜRKİYE**

ve imalat tesis(ler)inde üretilmiş

Bu belge ,

### EN 15088:2005

standardı'nın ZA Eki'nde tanımlanan performansın değişmezliğinin değerlendirilmesi ve doğrulanması ile ilgili tüm hükümlerin, Sistem 2+ altında uygulandığını ve

**fabrika üretim kontrolünün ilgili gereklerle uyum içerisinde olduğunun değerlendirildiğini göstermektedir.**

Bu Belge ilk olarak 19.08.2014 tarihinde düzenlenmiş ve Kapsam Değişikliğinin Yapılması sebebiyle 20.09.2019 tarihinde revize edilmiş olup, uyumlaştırılmış standart, yapı malzemesi, PDDD yöntemleri ya da üretim tesisindeki koşulları önemli ölçüde değiştirilmediği sürece, onaylanmış fabrika üretim kontrolü belgelendirme kuruluşu tarafından askıya alınmaz veya iptal edilmez ise geçerlidir.



**Sezai DOĞAN**  
Direktifler Müdürü



## TSE COVID-19 GÜVENLİ ÜRETİM BELGESİ



TÜRK STANDARDLARI ENSTİTÜSÜ

Bu Belge ile

**ARFEM İNŞAAT METAL TAŞ. TİC. SAN. A.Ş.**  
ORGANİZE SANAYİ BÖLGESİ 15. CAD. 110 ADA NO:12  
YENİŞEHİR/DİYARBAKIR

kuruluşunun TSE COVID-19 HİJYEN, ENFEKSİYON ÖNLEME VE KONTROL BELGELENDİRME PROGRAMI şartlarını yerine getirerek TSE COVID-19 GÜVENLİ ÜRETİM BELGESİ almaya hak kazandığını onaylar

Belge Numarası : GU-DYB-26/21

Düzenleme Tarihi : 16.04.2021

Gecerlilik Tarihi : 16.04.2022



MEHMET GENÇ  
TSE DİYARBAKIR BELGELENDİRME MÜDÜRÜ

Bu belge Türk Standardları Enstitüsünün kuruluşu hakkındaki 132 sayılı kanun uyarınca verilmiş olup, sadece yukarıda belirtilen kuruluş adresi için geçerlidir.

211904202110332955



## GENEL KATALOG

Standart Profiller	1 - 21
Doğrama Profilleri	24 - 115
Sineklik Profilleri	134
Mobilya Profilleri	120 - 133
Duşakabin Profilleri	136 - 140
Küpeşte Profilleri	142 - 185
Perde Profilleri	188 - 190
Cam Balkon Profilleri	192 - 213
KepenK Profilleri	216 - 217
Özel Profiller	220 - 233
Tente Profilleri	236
Soğutma Profilleri	238
Asansör Profilleri	240
Ofis Bölme Profilleri	242 - 254







**ARFEM**<sup>®</sup>  
ALÜMİNYUM  
**Standart Profiller**



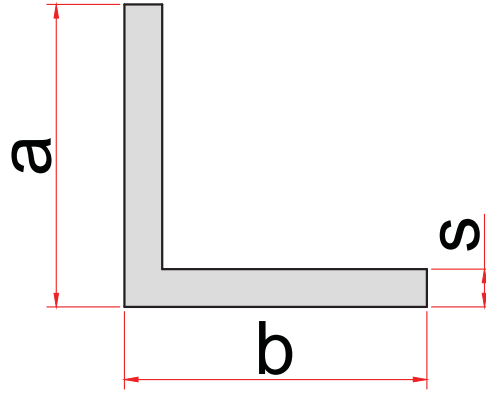

KOD CODE	<i>a</i> (mm)	<i>b</i> (mm)	<i>s</i> (mm)	Weight Ağırlık (kg/m)
1	20	80	1.25	0,332
2	4.1	40	1.30	0,151
13	10	150	1.50	0,645
14	20	20	1.10	0,117
15	25	25	1.10	0,146
16	30	30	1.20	0,192
17	20	40	1.10	0,176
18	20	60	1.20	0,257
22	50	50	5	1,282
34	20	20	2	0,205
44	20	30	1,10	1,146
45	40	40	1,20	0,253
122	20	100	1,30	0,416
123	20	120	1,30	0,486
124	4	20	1,20	0,073
135	23,5	23,5	1,50	0,184
139	40	40	4	0,820
145	40	40	3	0,623
155	25,1	75	1,60	0,454
156	18	40	1,40	0,211
157	18	70	1,30	0,305
158	18	80	1,40	0,364
775	27	27	3	0,413
776	36,5	36,5	3	0,567



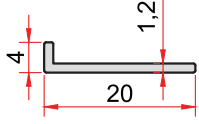

**KOD-CODE** *TEORİK AĞIRLIK*  
*THEORETICAL WEIGHT*  
124 0,073 Kg/m

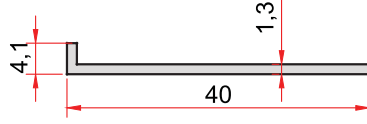

**KOD-CODE** *TEORİK AĞIRLIK*  
*THEORETICAL WEIGHT*  
2 0,151 Kg/m

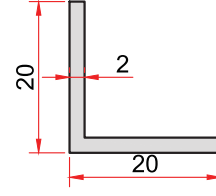

**KOD-CODE** *TEORİK AĞIRLIK*  
*THEORETICAL WEIGHT*  
34 0,205 Kg/m

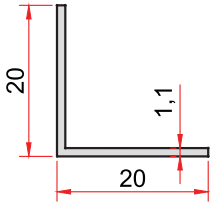

**KOD-CODE** *TEORİK AĞIRLIK*  
*THEORETICAL WEIGHT*  
14 0,117 Kg/m

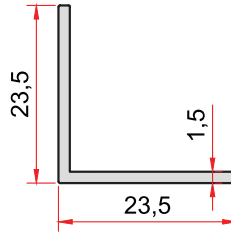

**KOD-CODE** *TEORİK AĞIRLIK*  
*THEORETICAL WEIGHT*  
135 0,184 Kg/m

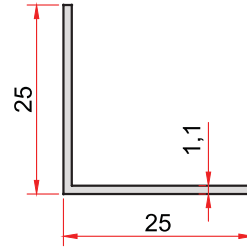

**KOD-CODE** *TEORİK AĞIRLIK*  
*THEORETICAL WEIGHT*  
15 0,146 Kg/m

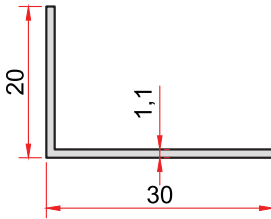

**KOD-CODE** *TEORİK AĞIRLIK*  
*THEORETICAL WEIGHT*  
44 0,145 Kg/m

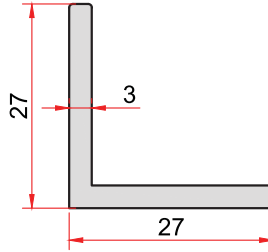

**KOD-CODE** *TEORİK AĞIRLIK*  
*THEORETICAL WEIGHT*  
775 0,413 Kg/m

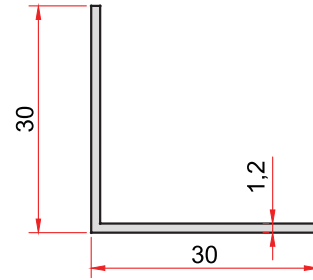

**KOD-CODE** *TEORİK AĞIRLIK*  
*THEORETICAL WEIGHT*  
16 0,192 Kg/m

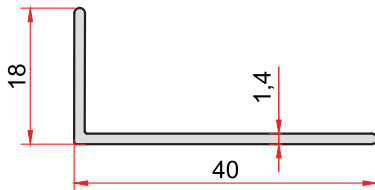

**KOD-CODE** *TEORİK AĞIRLIK*  
*THEORETICAL WEIGHT*  
156 0,211 Kg/m

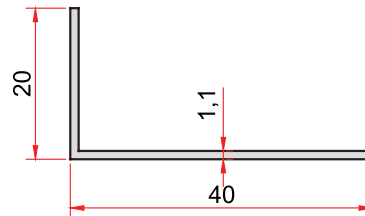

**KOD-CODE** *TEORİK AĞIRLIK*  
*THEORETICAL WEIGHT*  
17 0,176 Kg/m

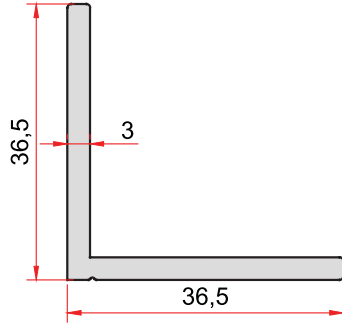

**KOD-CODE** *TEORİK AĞIRLIK*  
*THEORETICAL WEIGHT*  
**776** **0,567 Kg/m**

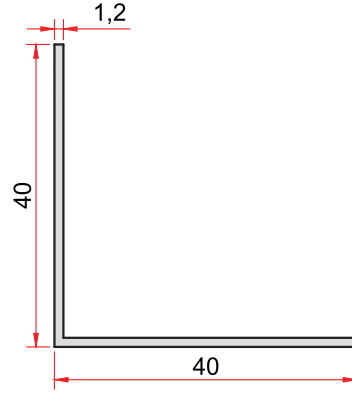

**KOD-CODE** *TEORİK AĞIRLIK*  
*THEORETICAL WEIGHT*  
**45** **0,253 Kg/m**

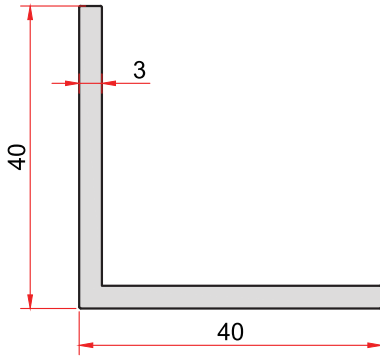

**KOD-CODE** *TEORİK AĞIRLIK*  
*THEORETICAL WEIGHT*  
**145** **0,623 Kg/m**

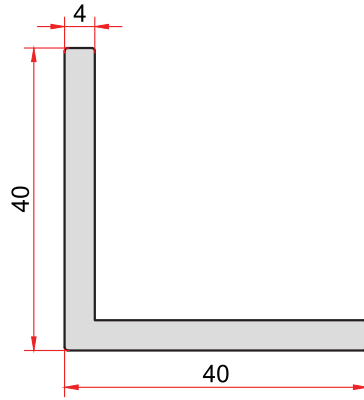

**KOD-CODE** *TEORİK AĞIRLIK*  
*THEORETICAL WEIGHT*  
**139** **0,820 Kg/m**

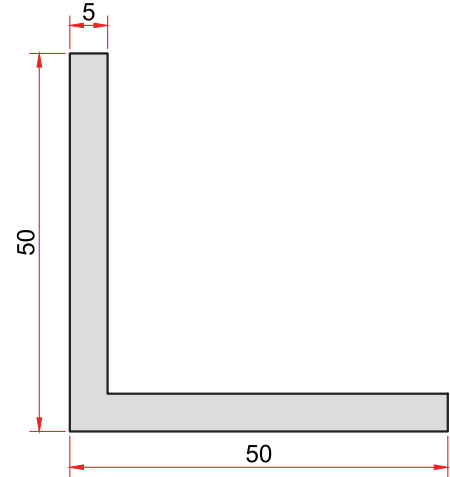

**KOD-CODE** *TEORİK AĞIRLIK*  
*THEORETICAL WEIGHT*  
**22** **1,282 Kg/m**

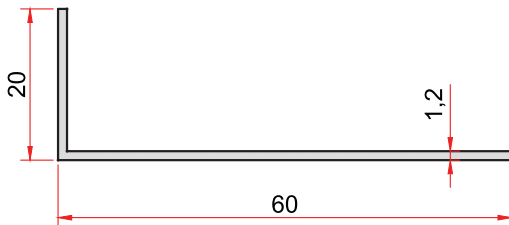

**KOD-CODE** *TEORİK AĞIRLIK*  
*THEORETICAL WEIGHT*  
**18** **0,257 Kg/m**

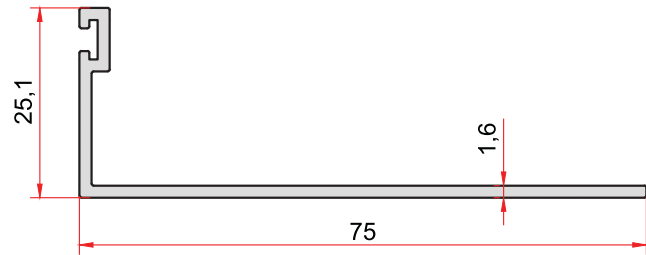

**KOD-CODE** *TEORİK AĞIRLIK*  
*THEORETICAL WEIGHT*  
**155** **0,454 Kg/m**

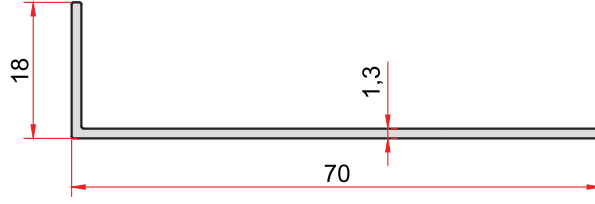

**KOD-CODE**      *TEORİK AĞIRLIK*  
*THEORETICAL WEIGHT*  
**157**              **0,305 Kg/m**

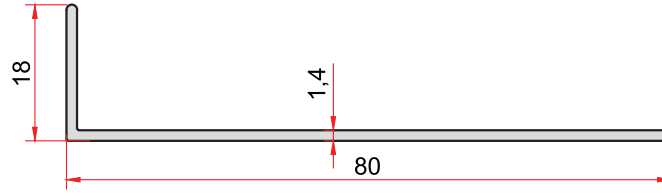

**KOD-CODE**      *TEORİK AĞIRLIK*  
*THEORETICAL WEIGHT*  
**158**              **0,364 Kg/m**

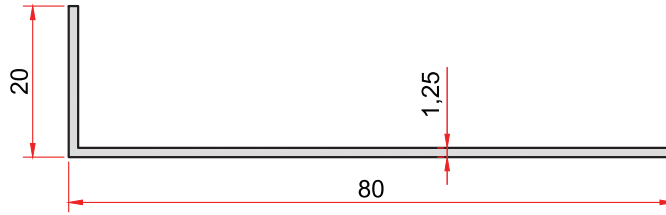

**KOD-CODE**      *TEORİK AĞIRLIK*  
*THEORETICAL WEIGHT*  
**1**                 **0,332 Kg/m**

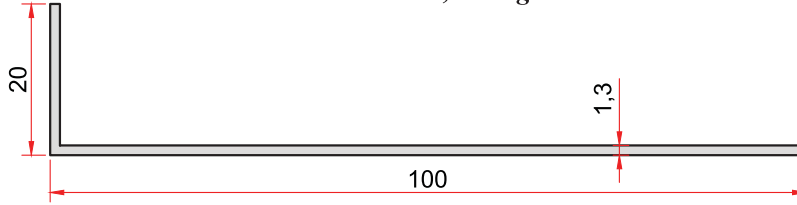

**KOD-CODE**      *TEORİK AĞIRLIK*  
*THEORETICAL WEIGHT*  
**122**             **0,416 Kg/m**

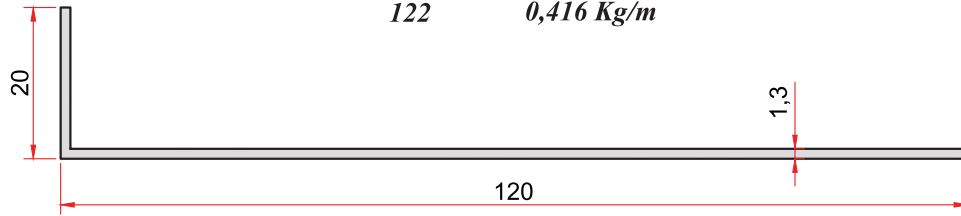

**KOD-CODE**      *TEORİK AĞIRLIK*  
*THEORETICAL WEIGHT*  
**123**             **0,486 Kg/m**

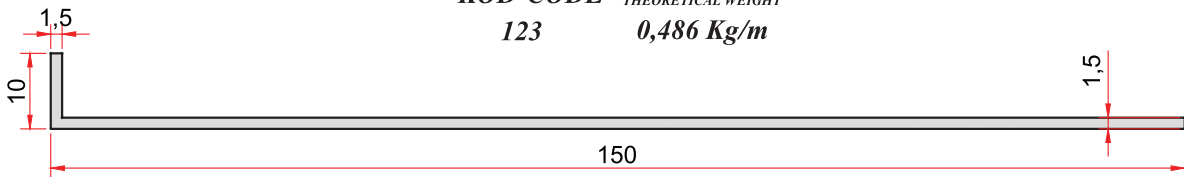

**KOD-CODE**      *TEORİK AĞIRLIK*  
*THEORETICAL WEIGHT*  
**13**               **0,645 Kg/m**



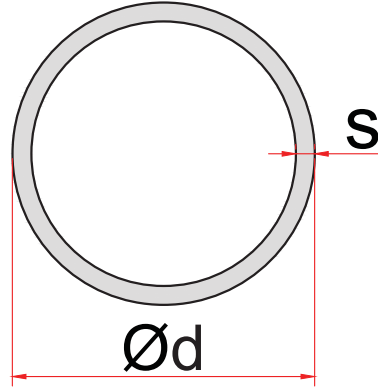

<i>KOD CODE</i>	<i>d (mm)</i>	<i>s (mm)</i>	<i>Weight Ağırlık (kg/m)</i>
11	60,6	1,10	0,558
12	60,2	1,10	0,532
27	150	4,60	5,673
28	120	4	3,934
29	90	3,60	2,639

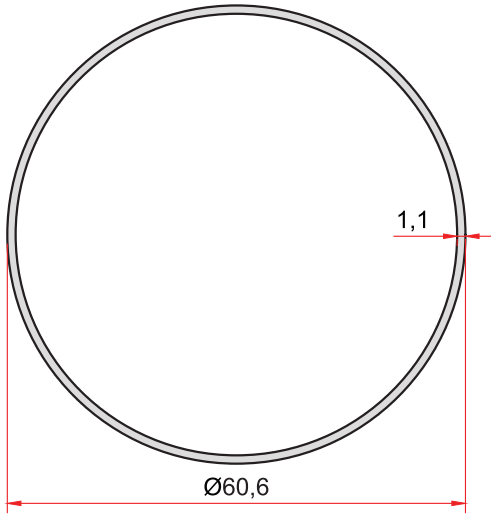

**KOD-CODE**      *TEORİK AĞIRLIK*  
*THEORETICAL WEIGHT*  
**11**              **0,558 Kg/m**

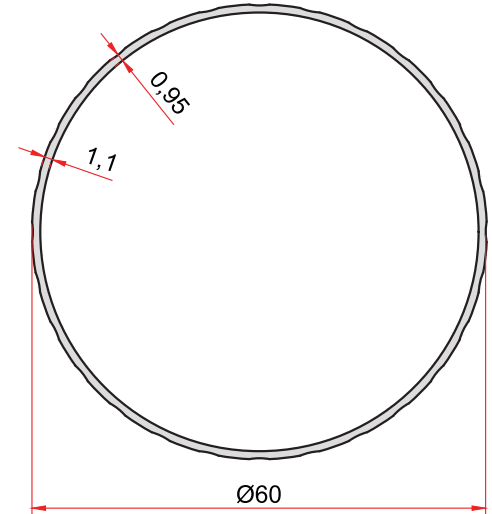

**KOD-CODE**      *TEORİK AĞIRLIK*  
*THEORETICAL WEIGHT*  
**12**              **0,532 Kg/m**



**KOD-CODE**      *TEORİK AĞIRLIK*  
*THEORETICAL WEIGHT*  
**27**              **5,673 Kg/m**

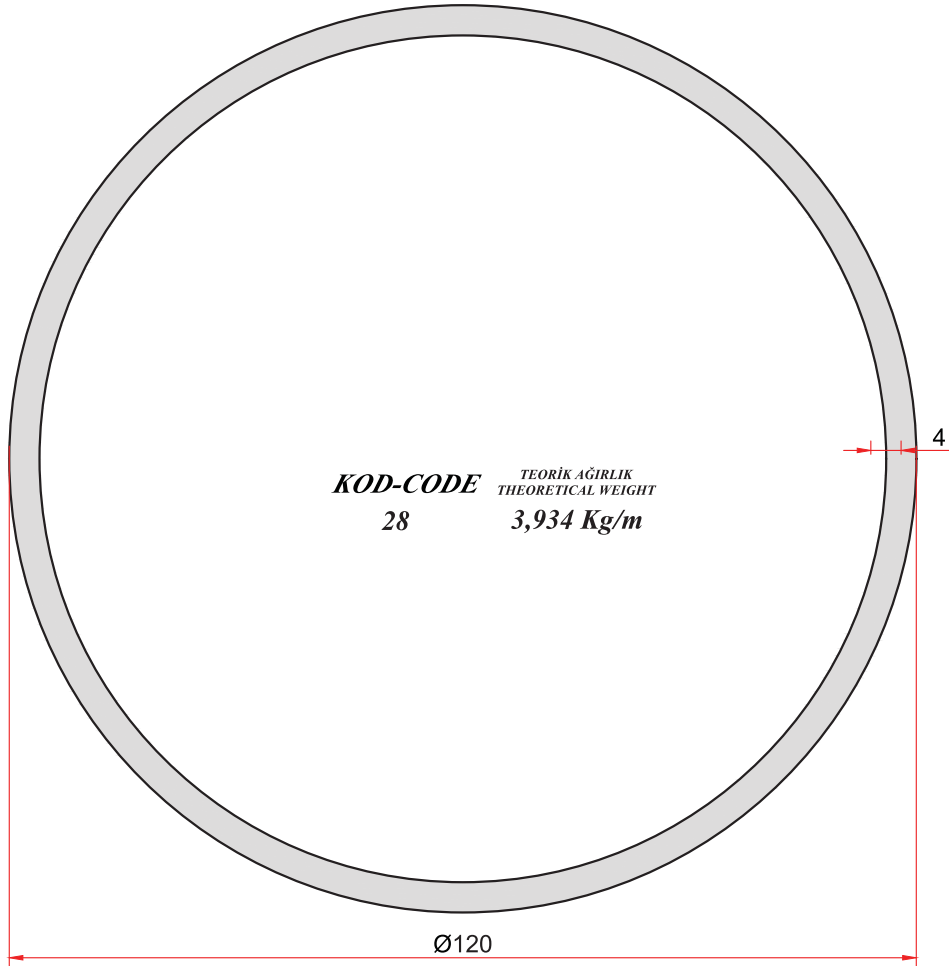
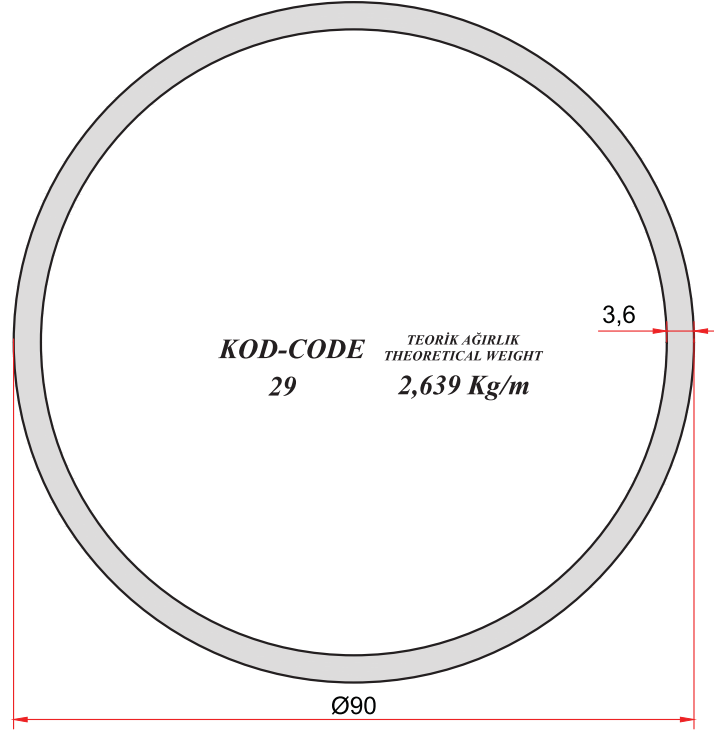



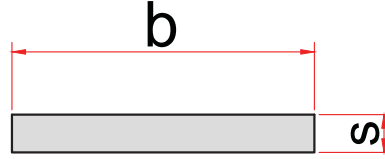

<i>KOD CODE</i>	<i>b (mm)</i>	<i>s (mm)</i>	<i>Weight Ağırlık (kg/m)</i>
25	30	6	0,486
64	20	3	0,162
65	20	4,5	0,243
66	25	5	0,337
67	40	2	0,216
68	40	4	0,432
69	40	25	2,700
70	45	2	0,243
71	50	10	1,350
72	50	15	2,025
73	50	20	2,700
74	50	25	3,375
125	43	43	5100
132	80	9	1,944
133	100	10	2,700
134	150	10	4,050
144	32	14	1,209
147	25,3	6	0,408
160	60	12	1,944

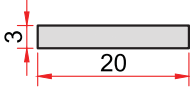

**KOD-CODE** *TEORİK AĞIRLIK*  
*THEORETICAL WEIGHT*  
64 0,162 Kg/m

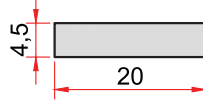

**KOD-CODE** *TEORİK AĞIRLIK*  
*THEORETICAL WEIGHT*  
65 0,243 Kg/m

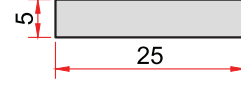

**KOD-CODE** *TEORİK AĞIRLIK*  
*THEORETICAL WEIGHT*  
66 0,337 Kg/m

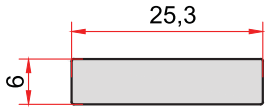

**KOD-CODE** *TEORİK AĞIRLIK*  
*THEORETICAL WEIGHT*  
147 0,408 Kg/m

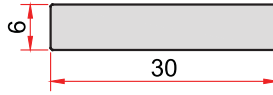

**KOD-CODE** *TEORİK AĞIRLIK*  
*THEORETICAL WEIGHT*  
25 0,486 Kg/m

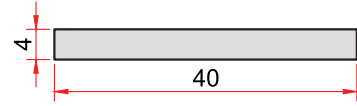

**KOD-CODE** *TEORİK AĞIRLIK*  
*THEORETICAL WEIGHT*  
68 0,432 Kg/m



**KOD-CODE** *TEORİK AĞIRLIK*  
*THEORETICAL WEIGHT*  
67 0,216 Kg/m

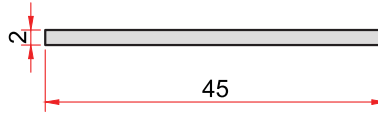

**KOD-CODE** *TEORİK AĞIRLIK*  
*THEORETICAL WEIGHT*  
70 0,243 Kg/m

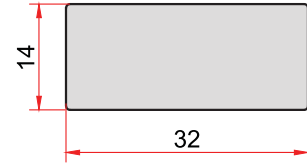

**KOD-CODE** *TEORİK AĞIRLIK*  
*THEORETICAL WEIGHT*  
144 1,209 Kg/m

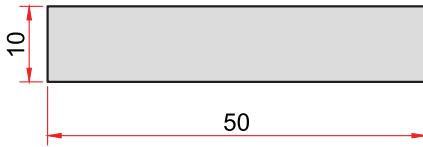

**KOD-CODE** *TEORİK AĞIRLIK*  
*THEORETICAL WEIGHT*  
71 1,350 Kg/m

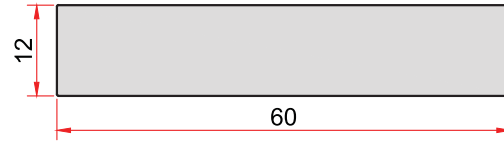

**KOD-CODE** *TEORİK AĞIRLIK*  
*THEORETICAL WEIGHT*  
160 1,944 Kg/m

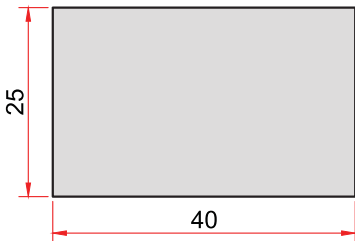

**KOD-CODE** *TEORİK AĞIRLIK*  
*THEORETICAL WEIGHT*  
69 2,700 Kg/m

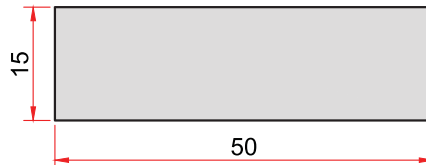

**KOD-CODE** *TEORİK AĞIRLIK*  
*THEORETICAL WEIGHT*  
72 2,025 Kg/m

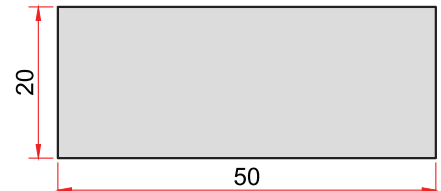

**KOD-CODE** *TEORİK AĞIRLIK*  
*THEORETICAL WEIGHT*  
73 2,700 Kg/m

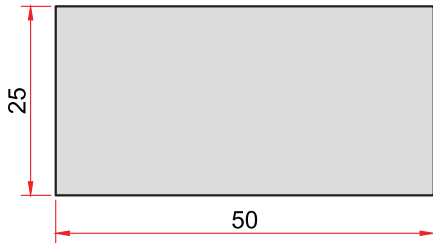

**KOD-CODE** *TEORİK AĞIRLIK*  
*THEORETICAL WEIGHT*  
74 3,375 Kg/m

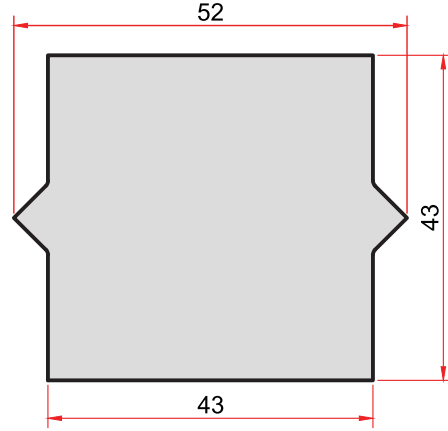

**KOD-CODE** *TEORİK AĞIRLIK*  
*THEORETICAL WEIGHT*  
125 5,100 Kg/m

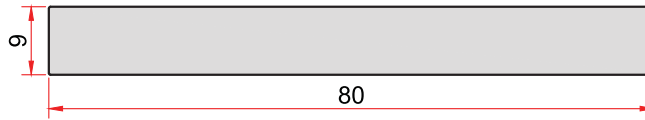

**KOD-CODE** *TEORİK AĞIRLIK*  
*THEORETICAL WEIGHT*  
132 1,944 Kg/m

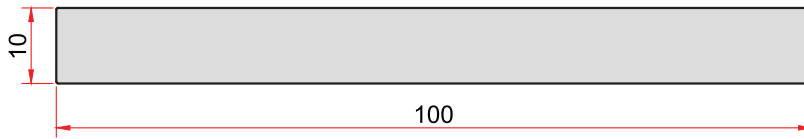

**KOD-CODE** *TEORİK AĞIRLIK*  
*THEORETICAL WEIGHT*  
133 2,700 Kg/m

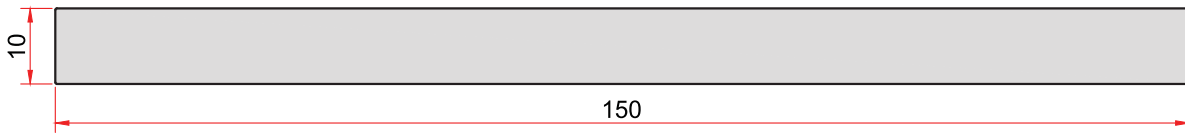

**KOD-CODE** *TEORİK AĞIRLIK*  
*THEORETICAL WEIGHT*  
134 4,050 Kg/m

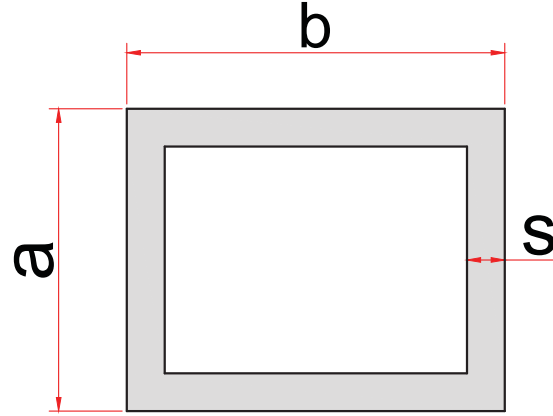

<i>KOD CODE</i>	<i>a (mm)</i>	<i>b (mm)</i>	<i>s (mm)</i>	<i>Weight Ağırlık (kg/m)</i>
10	80	30	1,50	0,864
20	70	30	1,50	0,786
23	75	32	1	0,567
24	40	60	1,40	0,734
31	40	20	1,80	0,548
32	30	25	1,20	0,341
33	25	25	1,20	0,308
35	50	40	1	0,475
46	15	25	1,20	0,243
48	20	20	2	0,389
49	20	30	1,30	0,332
50	20	40	1,20	0,376
51	20	40	2	0,605
53	25	25	2	0,497
54	30	50	2	0,821
56	40	40	1,20	0,502
59	40	80	1,20	0,761
60	40	80	2	1,253
61	45	45	2	0,929
91	20	40	1	0,313



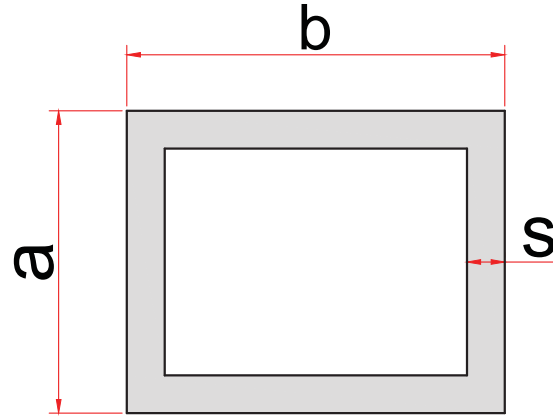

<i>KOD CODE</i>	<i>a (mm)</i>	<i>b (mm)</i>	<i>s (mm)</i>	<i>Weight Ağırlık (kg/m)</i>
92	80	80	2	1,685
93	70	70	1,30	0,964
94	40	80	1,30	0,824
95	40	60	1,30	0,683
96	20	35	1,20	0,340
111	20	60	1,50	0,623
112	20	80	1,50	0,785
113	20	100	1,50	0,947
114	17	25	1,20	0,256
115	20	50	1,50	0,542
116	50	95	1,50	1,150
117	50	100	2	1,576
118	60	120	2	1,900
119	50	50	1,50	0,785
120	60	60	1,50	0,947

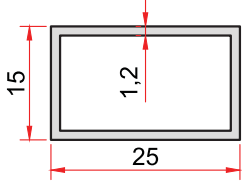

**KOD-CODE** TEORİK AĞIRLIK  
46 THEORETICAL WEIGHT  
0,243 Kg/m

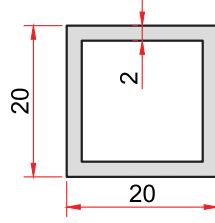

**KOD-CODE** TEORİK AĞIRLIK  
48 THEORETICAL WEIGHT  
0,389 Kg/m

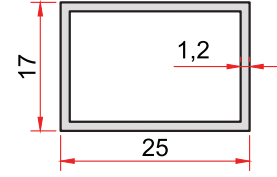

**KOD-CODE** TEORİK AĞIRLIK  
114 THEORETICAL WEIGHT  
0,256 Kg/m

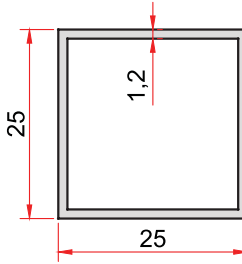

**KOD-CODE** TEORİK AĞIRLIK  
33 THEORETICAL WEIGHT  
0,308 Kg/m

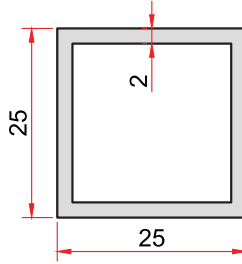

**KOD-CODE** TEORİK AĞIRLIK  
53 THEORETICAL WEIGHT  
0,497 Kg/m

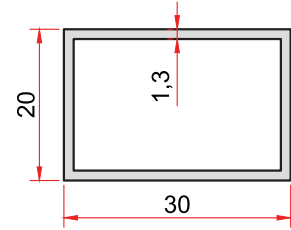

**KOD-CODE** TEORİK AĞIRLIK  
49 THEORETICAL WEIGHT  
0,332 Kg/m

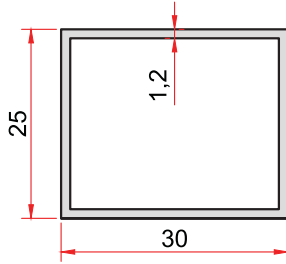

**KOD-CODE** TEORİK AĞIRLIK  
32 THEORETICAL WEIGHT  
0,341 Kg/m

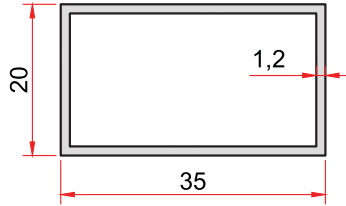

**KOD-CODE** TEORİK AĞIRLIK  
96 THEORETICAL WEIGHT  
0,340 Kg/m

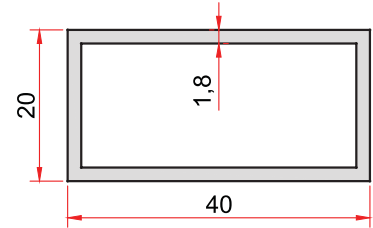

**KOD-CODE** TEORİK AĞIRLIK  
31 THEORETICAL WEIGHT  
0,548 Kg/m

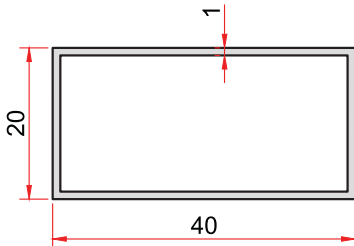

**KOD-CODE** TEORİK AĞIRLIK  
91 THEORETICAL WEIGHT  
0,313 Kg/m

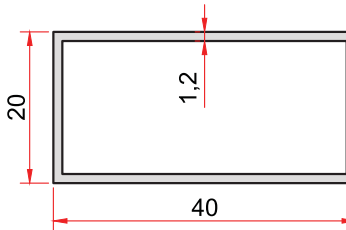

**KOD-CODE** TEORİK AĞIRLIK  
50 THEORETICAL WEIGHT  
0,376 Kg/m

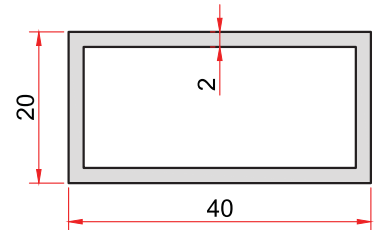

**KOD-CODE** TEORİK AĞIRLIK  
51 THEORETICAL WEIGHT  
0,605 Kg/m

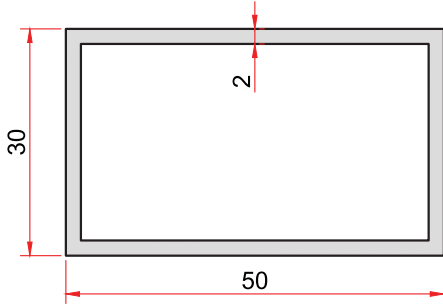

**KOD-CODE** *TEORİK AĞIRLIK*  
*THEORETICAL WEIGHT*  
**54** **0,821 Kg/m**

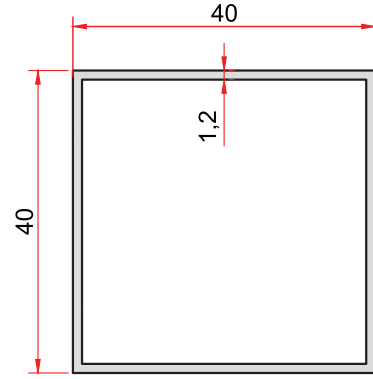

**KOD-CODE** *TEORİK AĞIRLIK*  
*THEORETICAL WEIGHT*  
**56** **0,502 Kg/m**

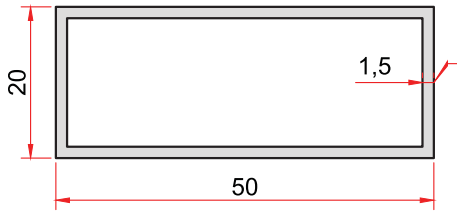

**KOD-CODE** *TEORİK AĞIRLIK*  
*THEORETICAL WEIGHT*  
**115** **0,542 Kg/m**

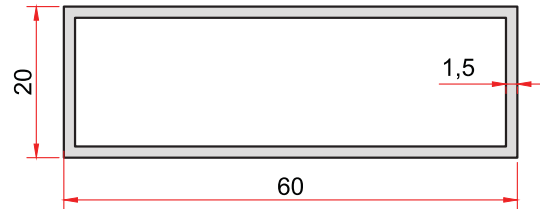

**KOD-CODE** *TEORİK AĞIRLIK*  
*THEORETICAL WEIGHT*  
**111** **0,623 Kg/m**

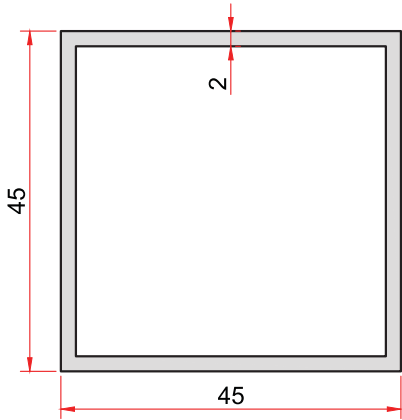

**KOD-CODE** *TEORİK AĞIRLIK*  
*THEORETICAL WEIGHT*  
**61** **0,929 Kg/m**

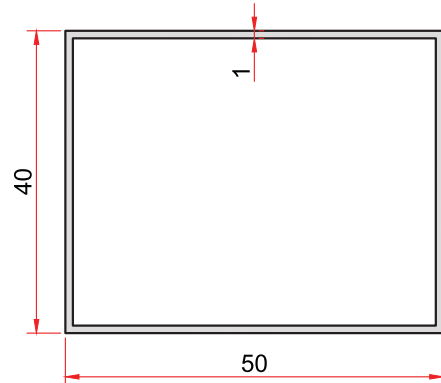

**KOD-CODE** *TEORİK AĞIRLIK*  
*THEORETICAL WEIGHT*  
**35** **0,475 Kg/m**

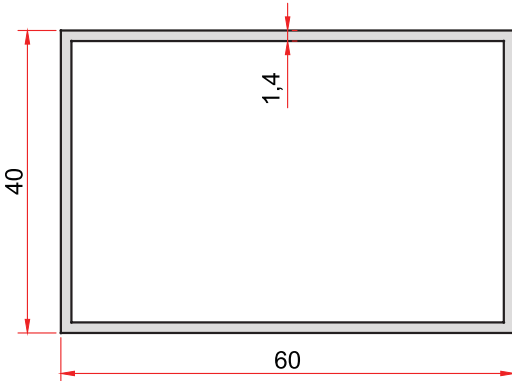

**KOD-CODE** *TEORİK AĞIRLIK*  
*THEORETICAL WEIGHT*  
**24** **0,734 Kg/m**

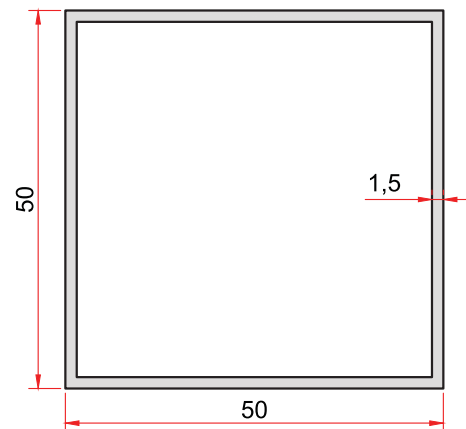

**KOD-CODE** *TEORİK AĞIRLIK*  
*THEORETICAL WEIGHT*  
**119** **0,785 Kg/m**

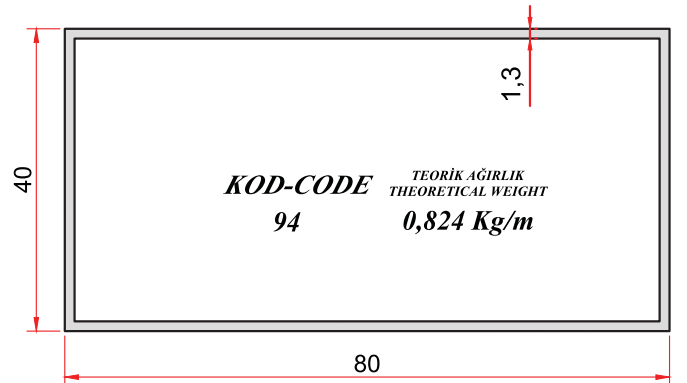
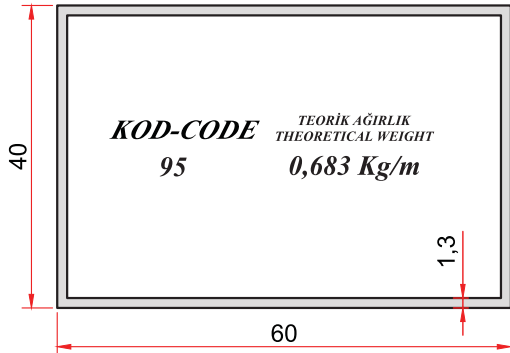
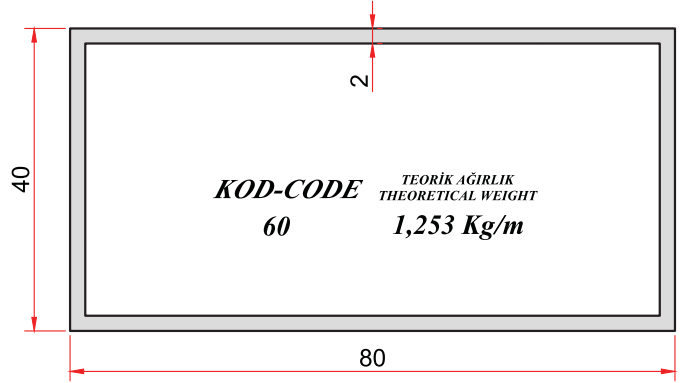
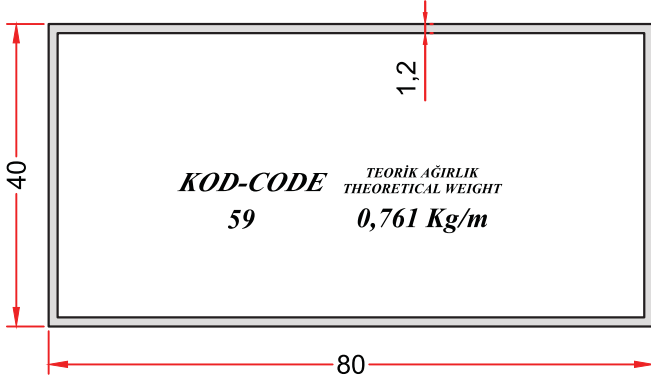
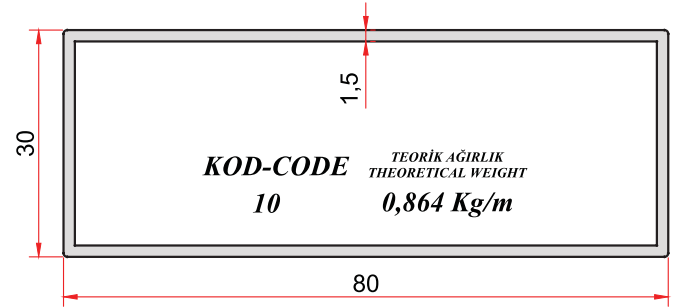
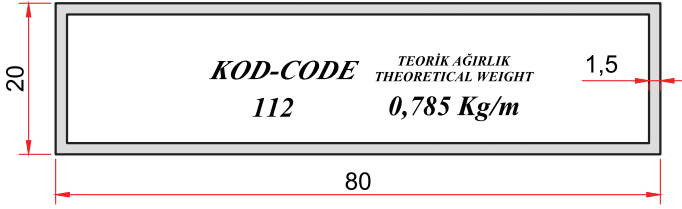
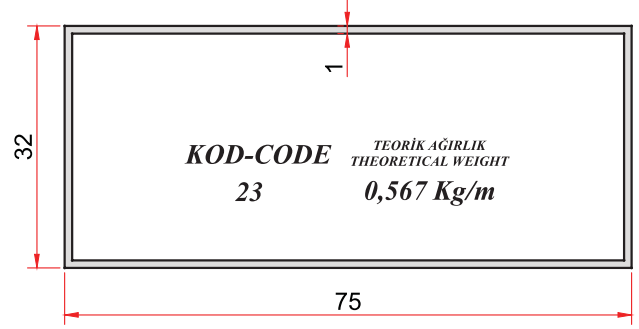
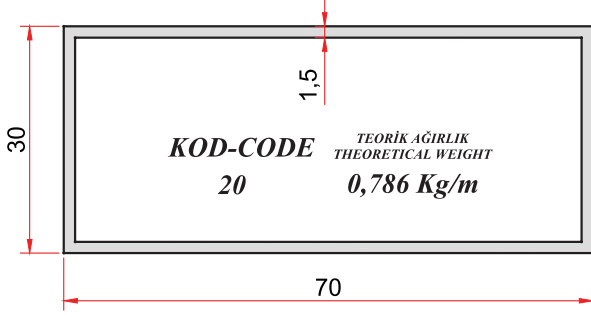

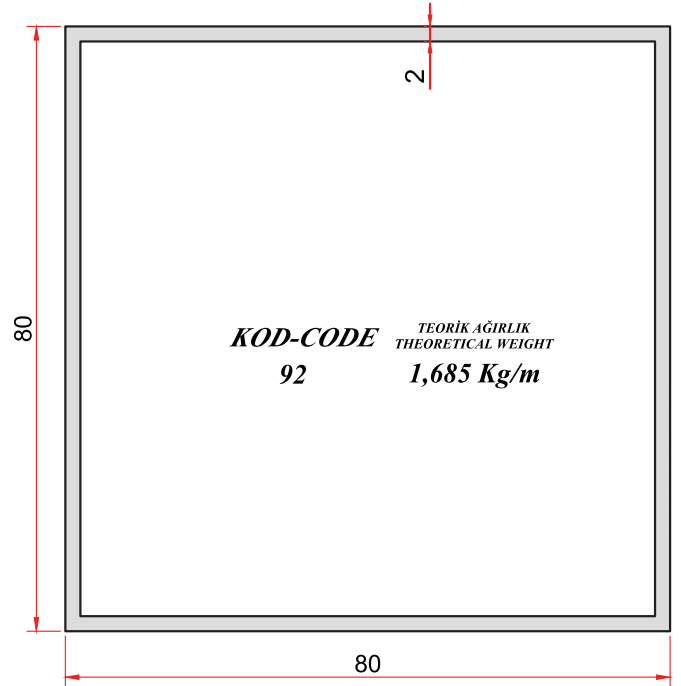
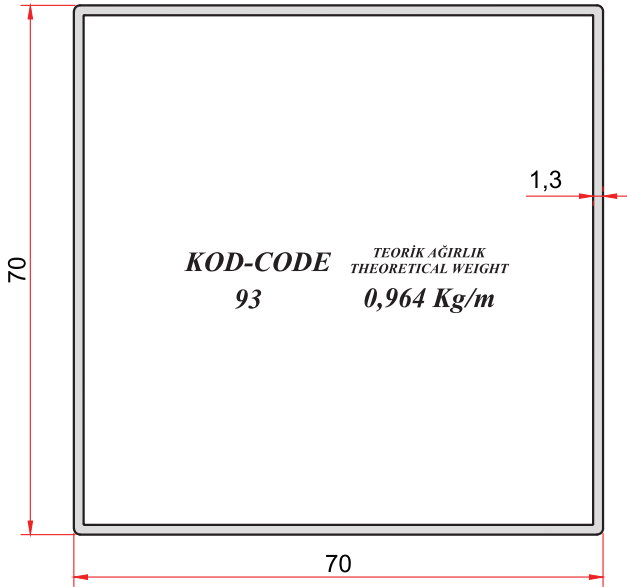
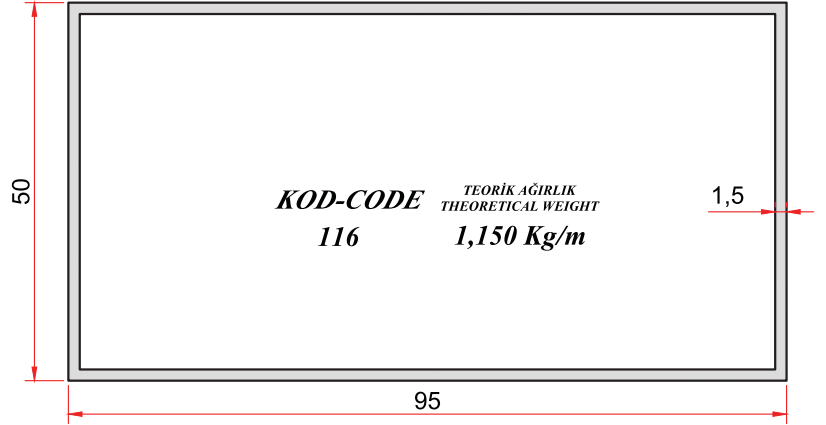
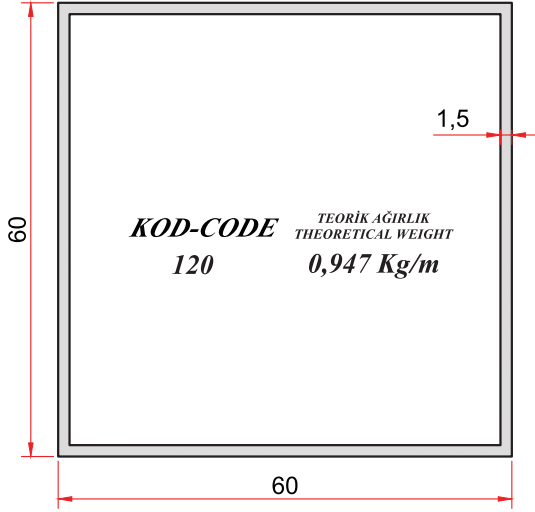



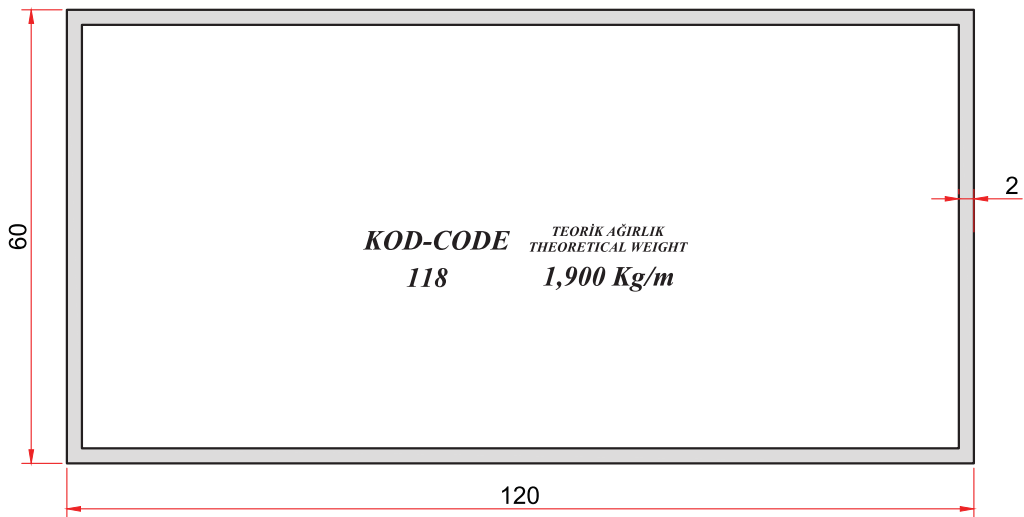
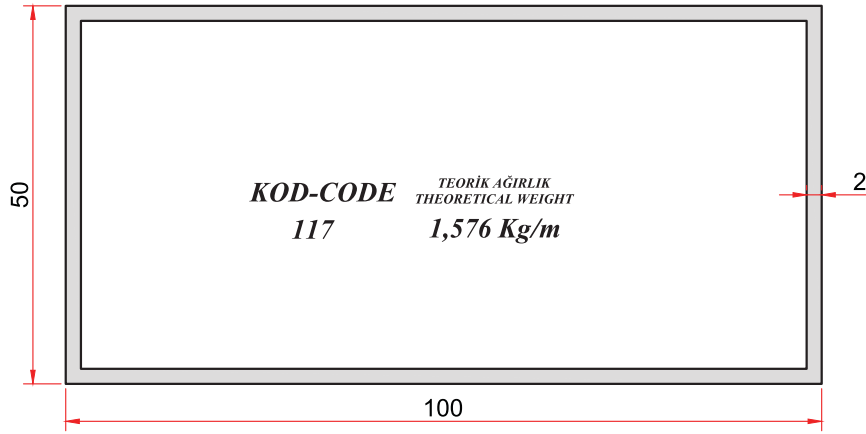
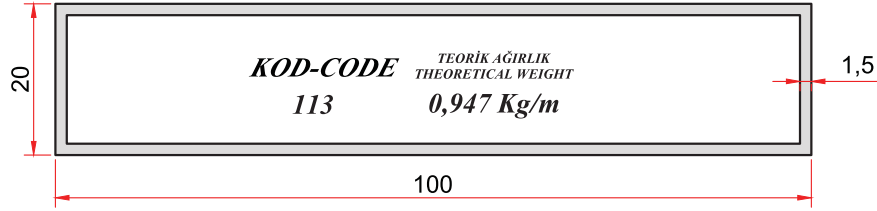

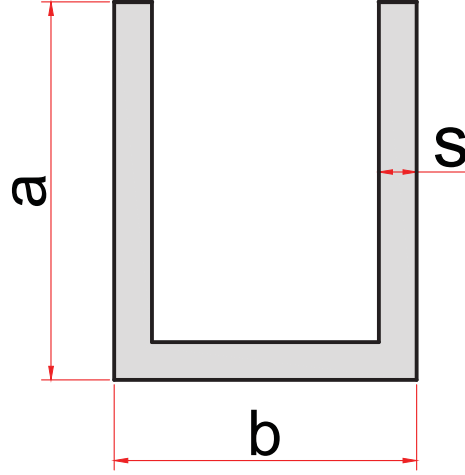

<i>KOD CODE</i>	<i>a (mm)</i>	<i>b (mm)</i>	<i>s (mm)</i>	<i>Weight Ağırlık (kg/m)</i>
26	20	40	2	0,410
82	11,2	15,5	1,10	0,105
83	17	17	1,10	0,146
84	15	11,6	1,80	0,184
85	23	30	1,20	0,238
86	33	65	5	1,633
87	30	30	3	0,680
88	60	56,2	5	2,244
142	20	33	1,50	0,284
7035	20	14,1	1,40	0,194

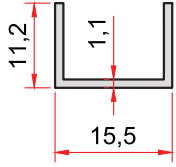

**KOD-CODE** *TEORİK AĞIRLIK*  
*THEORETICAL WEIGHT*  
**82** **0,105 Kg/m**

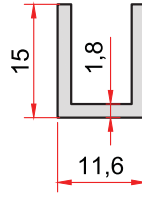

**KOD-CODE** *TEORİK AĞIRLIK*  
*THEORETICAL WEIGHT*  
**84** **0,184 Kg/m**

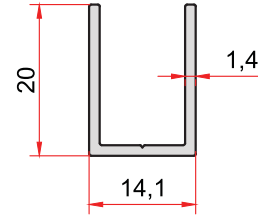

**KOD-CODE** *TEORİK AĞIRLIK*  
*THEORETICAL WEIGHT*  
**7035** **0,194 Kg/m**

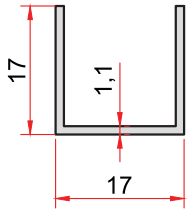

**KOD-CODE** *TEORİK AĞIRLIK*  
*THEORETICAL WEIGHT*  
**83** **0,146 Kg/m**

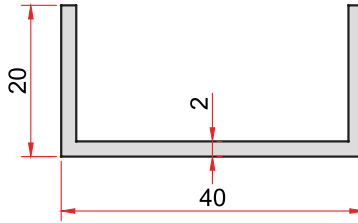

**KOD-CODE** *TEORİK AĞIRLIK*  
*THEORETICAL WEIGHT*  
**26** **0,410 Kg/m**

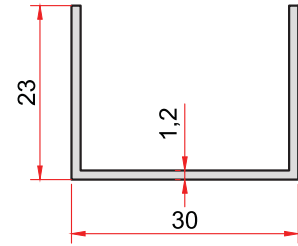

**KOD-CODE** *TEORİK AĞIRLIK*  
*THEORETICAL WEIGHT*  
**85** **0,238 Kg/m**

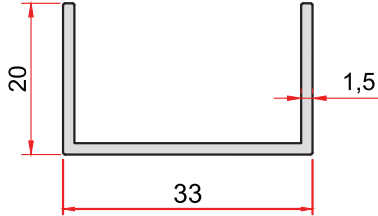

**KOD-CODE** *TEORİK AĞIRLIK*  
*THEORETICAL WEIGHT*  
**142** **0,284 Kg/m**

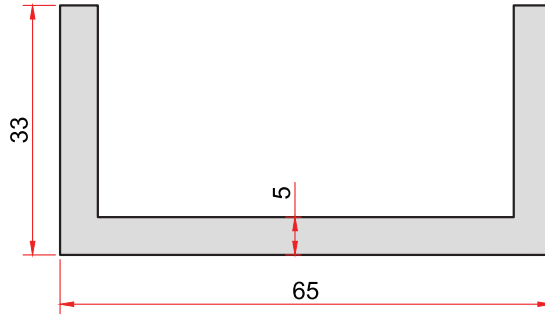

**KOD-CODE** *TEORİK AĞIRLIK*  
*THEORETICAL WEIGHT*  
**86** **1,633 Kg/m**

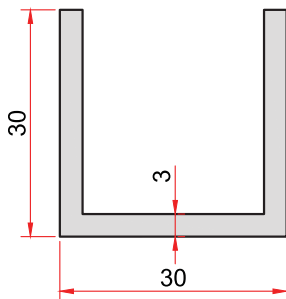

**KOD-CODE** *TEORİK AĞIRLIK*  
*THEORETICAL WEIGHT*  
**87** **0,680 Kg/m**

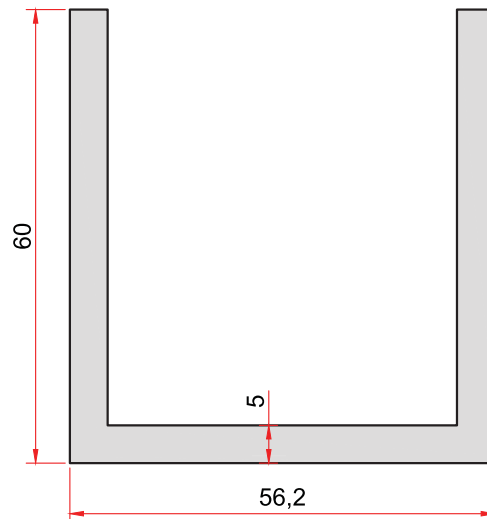

**KOD-CODE** *TEORİK AĞIRLIK*  
*THEORETICAL WEIGHT*  
**88** **2,244 Kg/m**

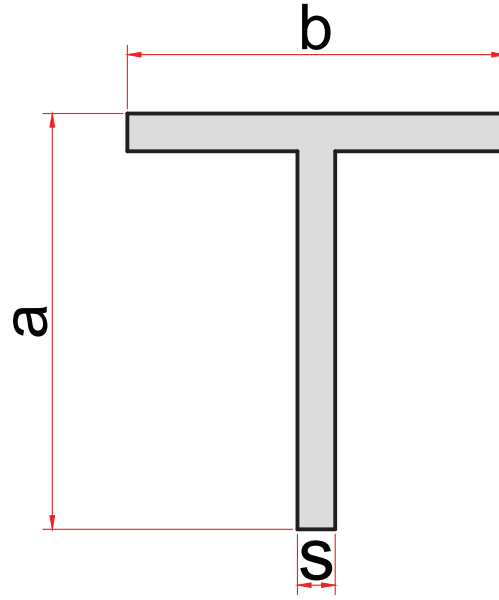

<b>KOD CODE</b>	<b>a (mm)</b>	<b>b (mm)</b>	<b>s (mm)</b>	<b>Weight Ağırlık (kg/m)</b>
19	25	25	1,2	0,157
75	30	30	1,20	0,189
76	36	25	2	0,319
77	50	50	1,80	0,478
78	50	50	2	0,529
79	50	50	2,30	0,607
80	50	50	3	0,786
81	50	60	2	0,583
143	36,25	48	3	0,726

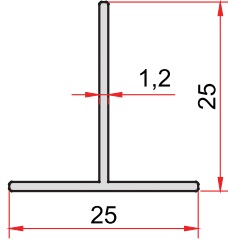

**KOD-CODE** 19  
**TEORİK AĞIRLIK**  
**THEORETICAL WEIGHT**  
0,157 Kg/m

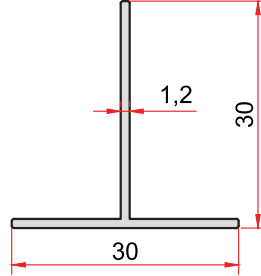

**KOD-CODE** 75  
**TEORİK AĞIRLIK**  
**THEORETICAL WEIGHT**  
0,189 Kg/m

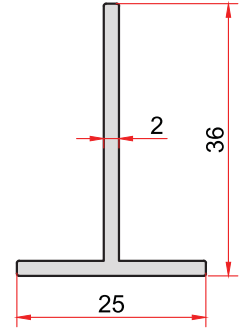

**KOD-CODE** 76  
**TEORİK AĞIRLIK**  
**THEORETICAL WEIGHT**  
0,319 Kg/m

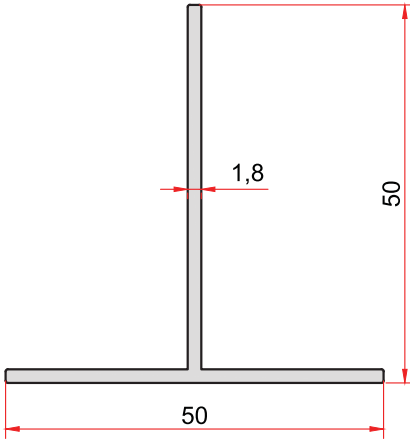

**KOD-CODE** 77  
**TEORİK AĞIRLIK**  
**THEORETICAL WEIGHT**  
0,478 Kg/m

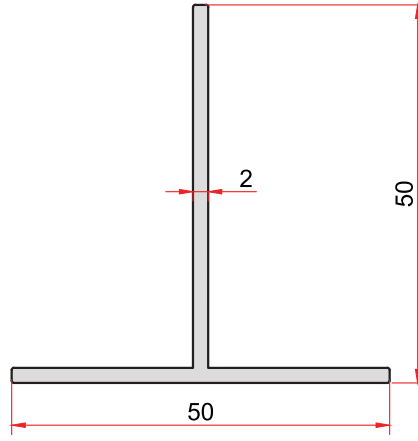

**KOD-CODE** 78  
**TEORİK AĞIRLIK**  
**THEORETICAL WEIGHT**  
0,529 Kg/m

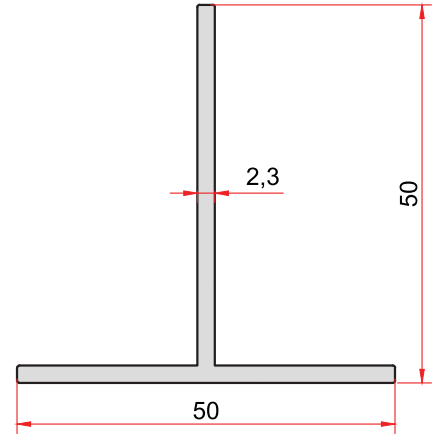

**KOD-CODE** 79  
**TEORİK AĞIRLIK**  
**THEORETICAL WEIGHT**  
0,607 Kg/m

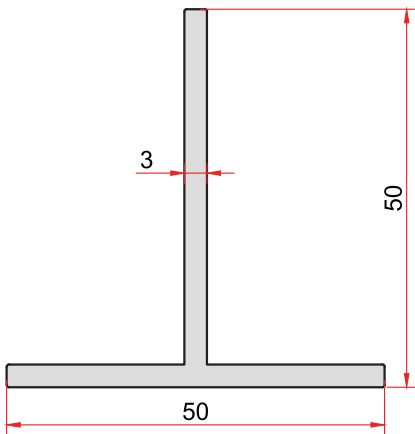

**KOD-CODE** 80  
**TEORİK AĞIRLIK**  
**THEORETICAL WEIGHT**  
0,786 Kg/m

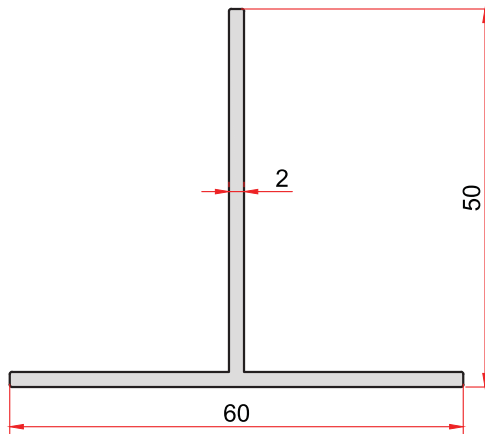

**KOD-CODE** 81  
**TEORİK AĞIRLIK**  
**THEORETICAL WEIGHT**  
0,583 Kg/m

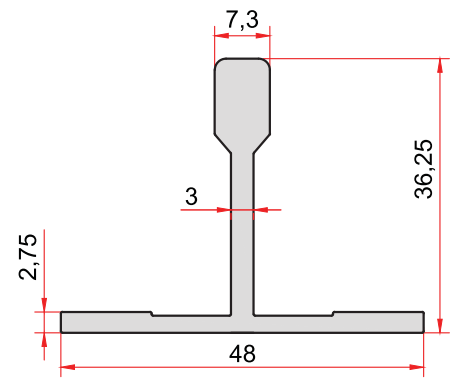

**KOD-CODE** 143  
**TEORİK AĞIRLIK**  
**THEORETICAL WEIGHT**  
0,726 Kg/m







Y.E.S. ПНЕФАРИК  
11432 345 112 112

Y.E.S. ПНЕФАРИК  
11432 345 112 112

**ARFEM**<sup>®</sup>  
ALÜMİNYUM

**Doğrama Profilleri**



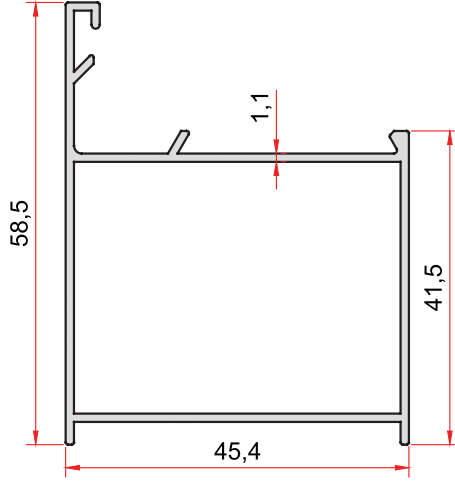

**KOD-CODE** *TEORİK AĞIRLIK*  
*THEORETICAL WEIGHT*  
822 0,599 Kg/m

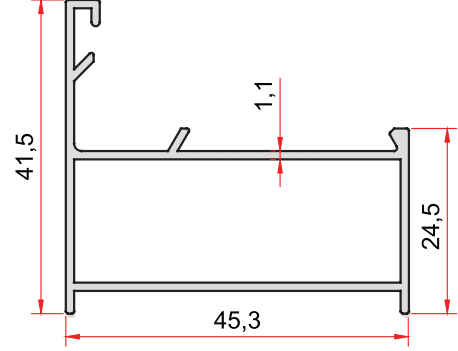

**KOD-CODE** *TEORİK AĞIRLIK*  
*THEORETICAL WEIGHT*  
823 0,499 Kg/m

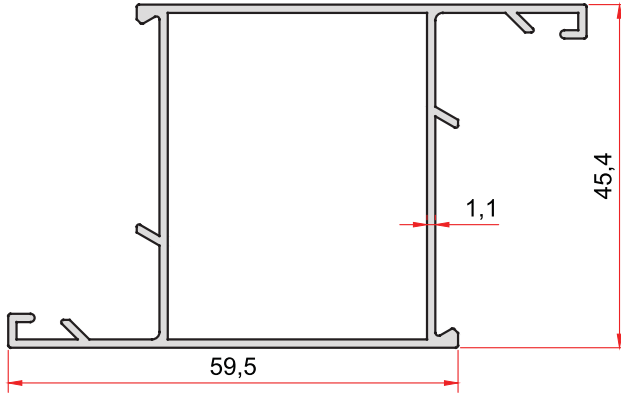

**KOD-CODE** *TEORİK AĞIRLIK*  
*THEORETICAL WEIGHT*  
824 0,702 Kg/m

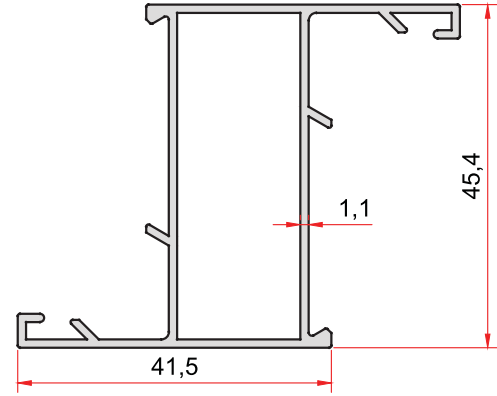

**KOD-CODE** *TEORİK AĞIRLIK*  
*THEORETICAL WEIGHT*  
825 0,599 Kg/m

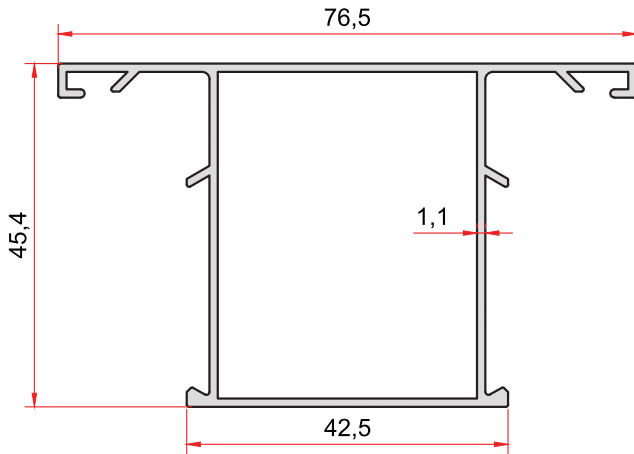

**KOD-CODE** *TEORİK AĞIRLIK*  
*THEORETICAL WEIGHT*  
826 0,702 Kg/m

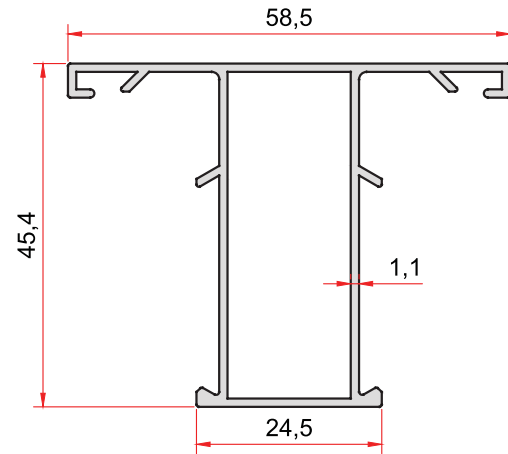

**KOD-CODE** *TEORİK AĞIRLIK*  
*THEORETICAL WEIGHT*  
827 0,594 Kg/m

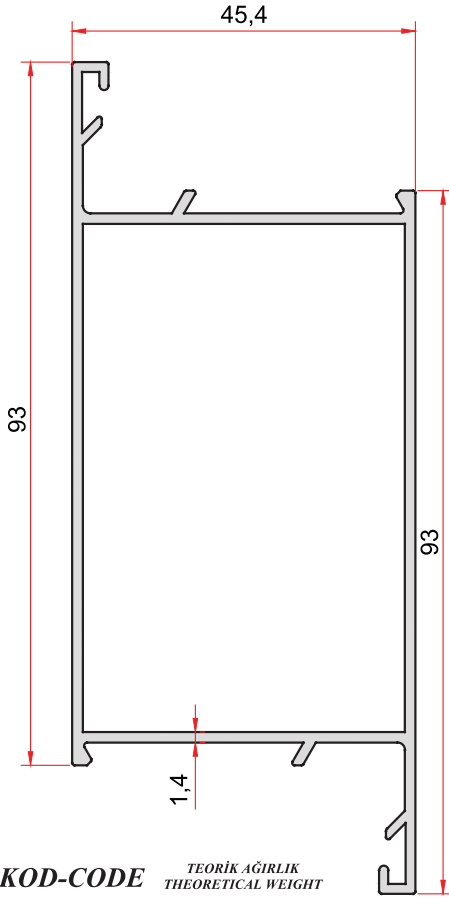

**KOD-CODE** *TEORİK AĞIRLIK*  
**830** *THEORETICAL WEIGHT*  
**1,118 Kg/m**

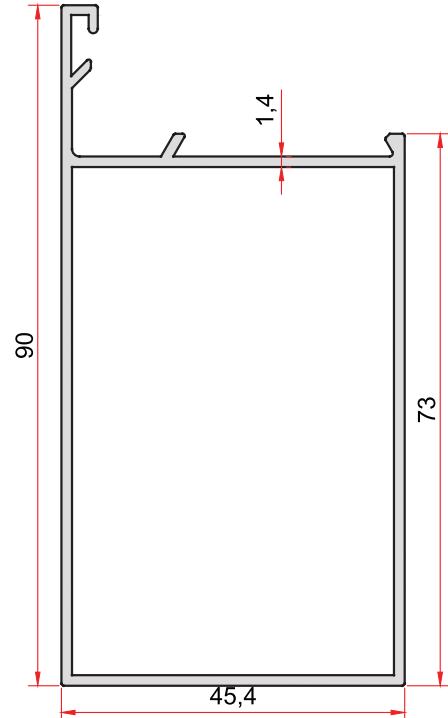

**KOD-CODE** *TEORİK AĞIRLIK*  
**829** *THEORETICAL WEIGHT*  
**0,985 Kg/m**

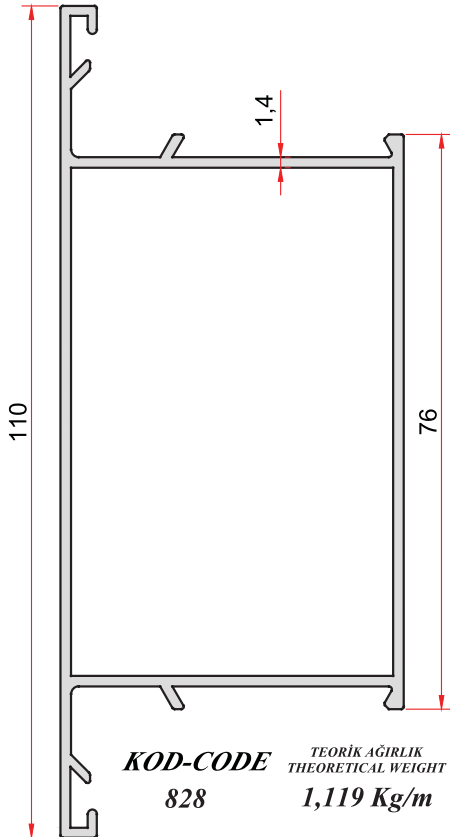

**KOD-CODE** *TEORİK AĞIRLIK*  
**828** *THEORETICAL WEIGHT*  
**1,119 Kg/m**

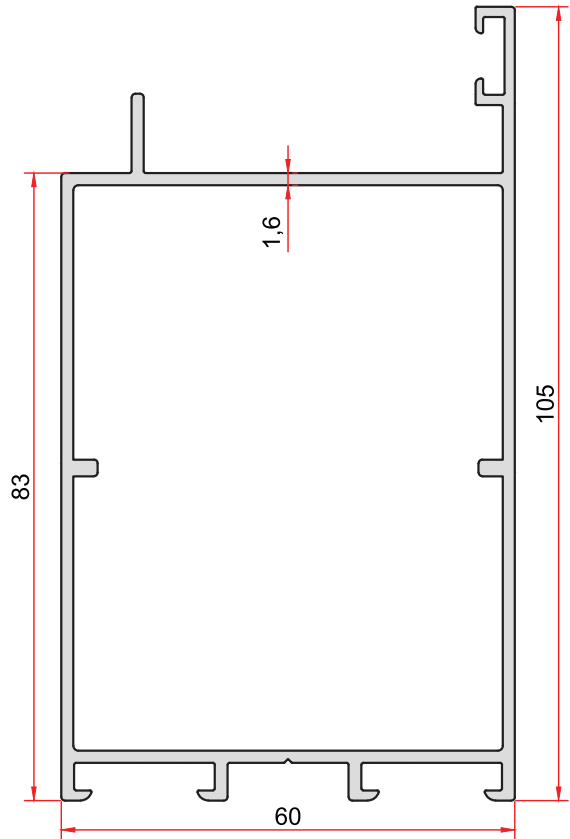

**KOD-CODE** *TEORİK AĞIRLIK*  
**1241** *THEORETICAL WEIGHT*  
**1,493 Kg/m**

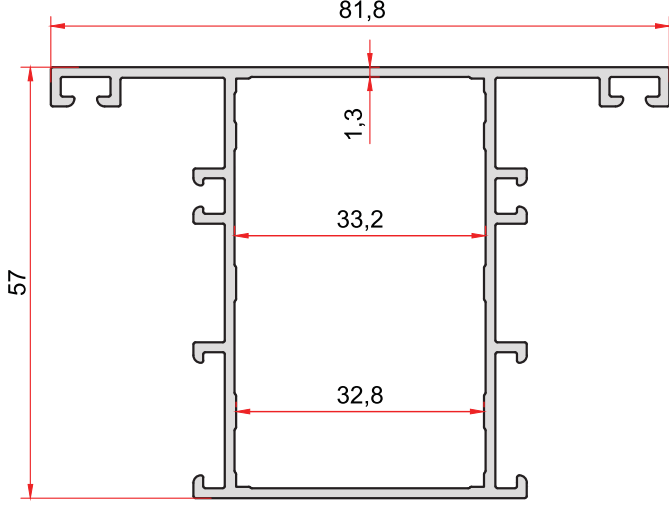

**KOD-CODE** *TEORİK AĞIRLIK*  
*THEORETICAL WEIGHT*  
7036 1,047 Kg/m

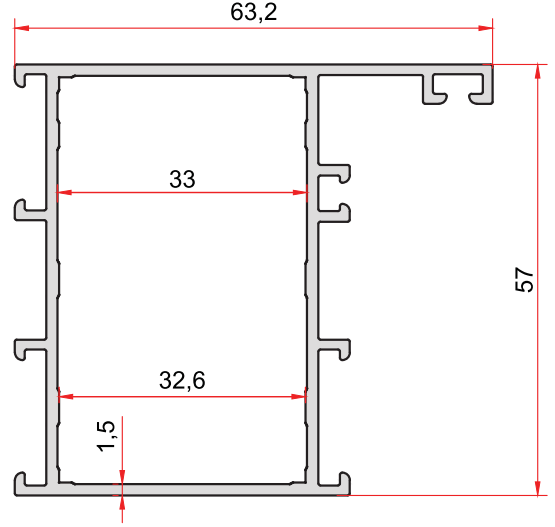

**KOD-CODE** *TEORİK AĞIRLIK*  
*THEORETICAL WEIGHT*  
7039 1,026 Kg/m

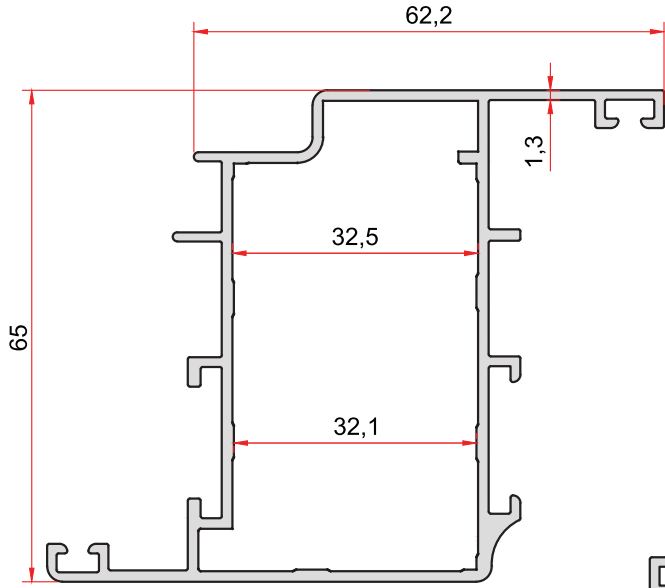

**KOD-CODE** *TEORİK AĞIRLIK*  
*THEORETICAL WEIGHT*  
7037 1,161 Kg/m

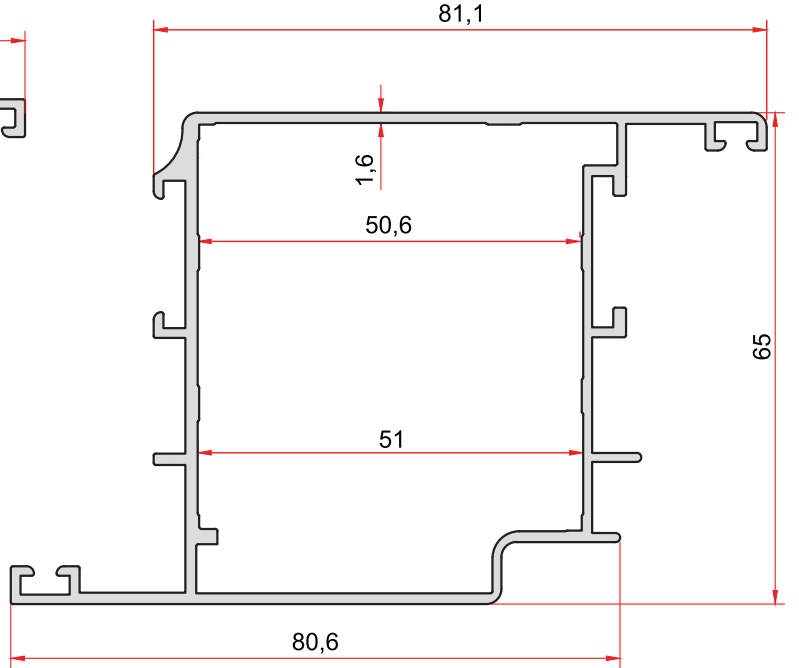

**KOD-CODE** *TEORİK AĞIRLIK*  
*THEORETICAL WEIGHT*  
7038 1,417 Kg/m



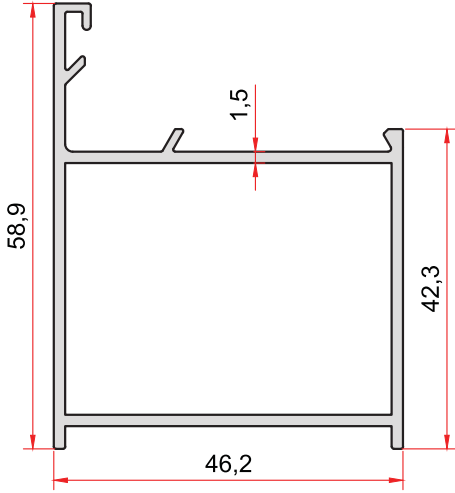

**KOD-CODE** *TEORİK AĞIRLIK*  
*THEORETICAL WEIGHT*  
**905** **0,801 Kg/m**

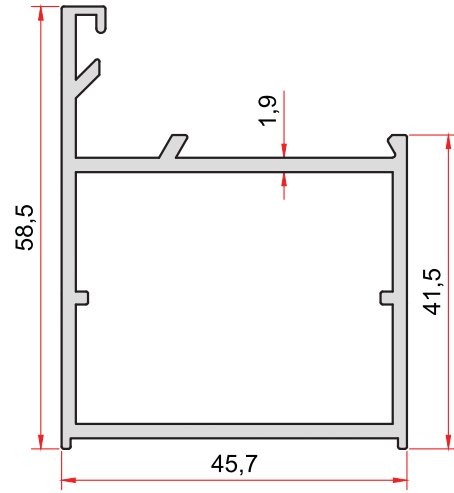

**KOD-CODE** *TEORİK AĞIRLIK*  
*THEORETICAL WEIGHT*  
**882** **1,010 Kg/m**

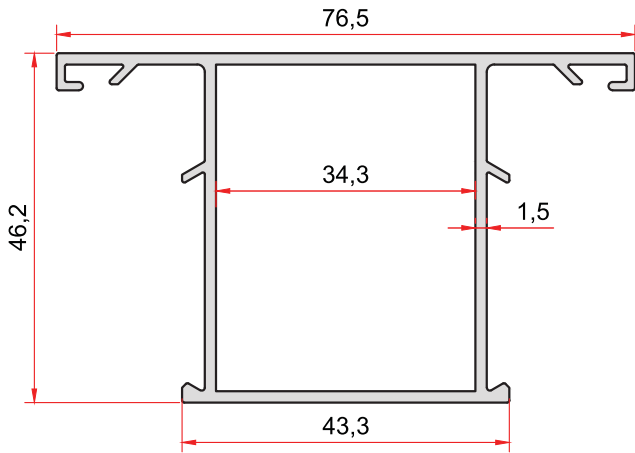

**KOD-CODE** *TEORİK AĞIRLIK*  
*THEORETICAL WEIGHT*  
**907** **0,921 Kg/m**

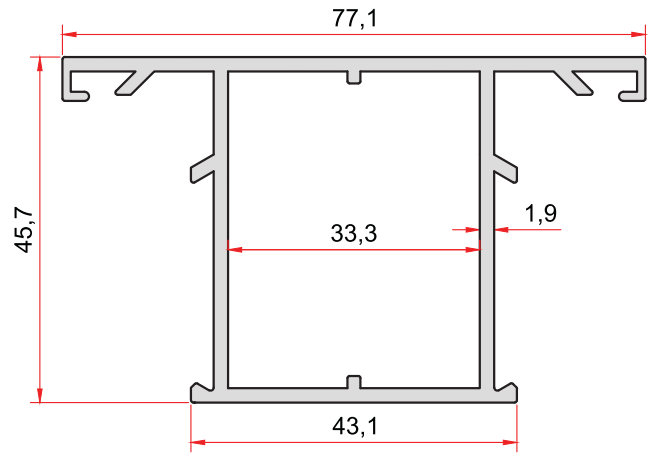

**KOD-CODE** *TEORİK AĞIRLIK*  
*THEORETICAL WEIGHT*  
**880** **1,177 Kg/m**

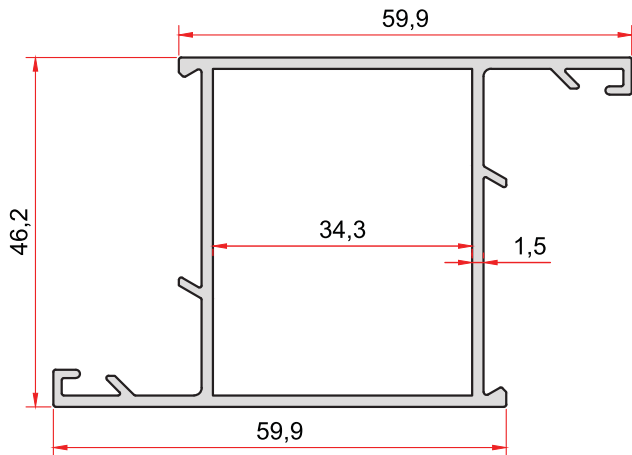

**KOD-CODE** *TEORİK AĞIRLIK*  
*THEORETICAL WEIGHT*  
**906** **0,921 Kg/m**

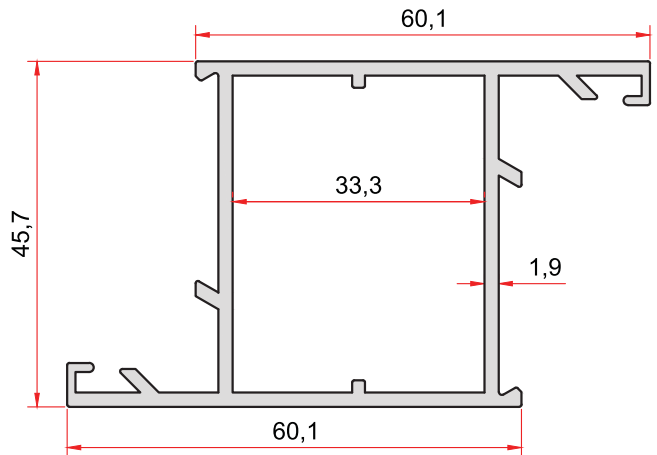

**KOD-CODE** *TEORİK AĞIRLIK*  
*THEORETICAL WEIGHT*  
**881** **1,177 Kg/m**

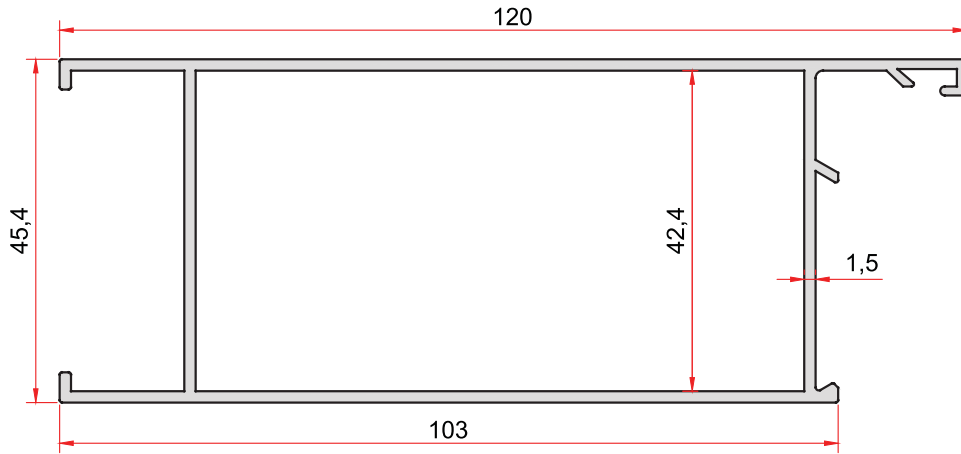

**KOD-CODE**      *TEORİK AĞIRLIK*  
*THEORETICAL WEIGHT*  
**831**            **1,307 Kg/m**

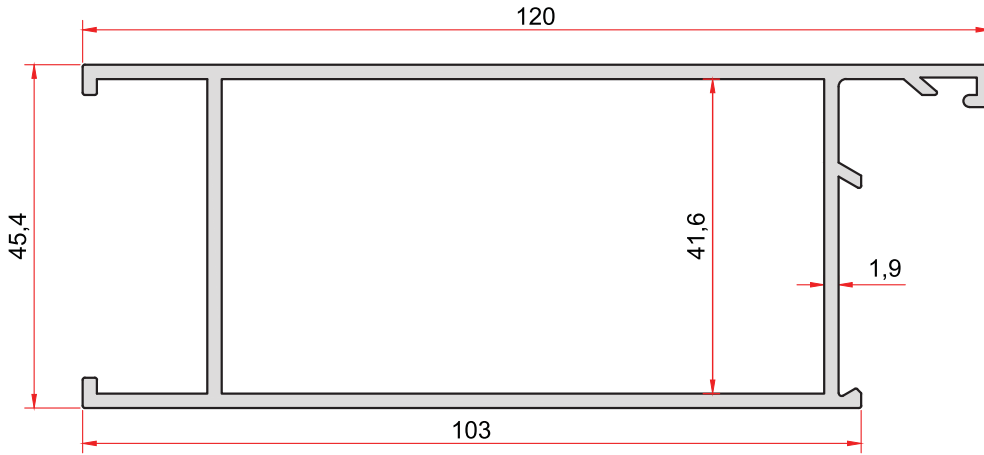

**KOD-CODE**      *TEORİK AĞIRLIK*  
*THEORETICAL WEIGHT*  
**883**            **1,642 Kg/m**

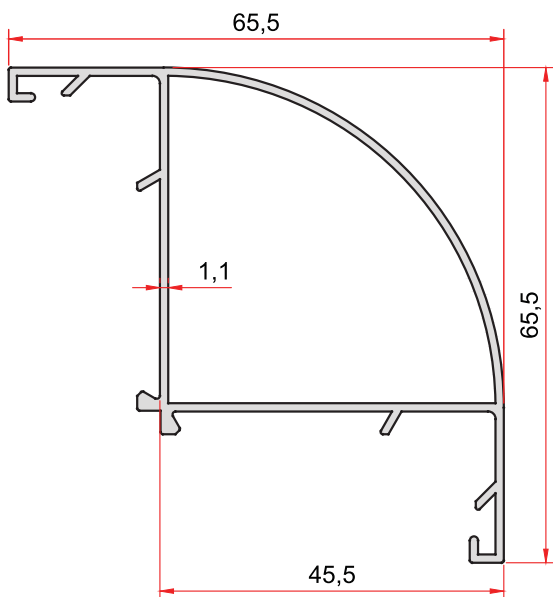

**KOD-CODE**      *TEORİK AĞIRLIK*  
*THEORETICAL WEIGHT*  
**838**            **0,699 Kg/m**

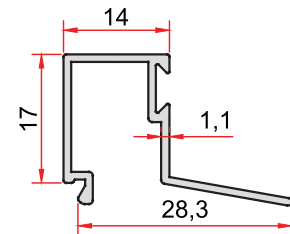

**KOD-CODE**      *TEORİK AĞIRLIK*  
*THEORETICAL WEIGHT*  
**835**            **0,205 Kg/m**

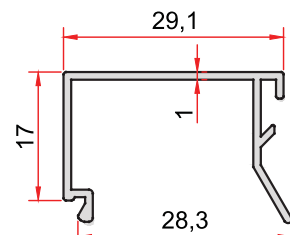

**KOD-CODE**      *TEORİK AĞIRLIK*  
*THEORETICAL WEIGHT*  
**833**            **0,208 Kg/m**

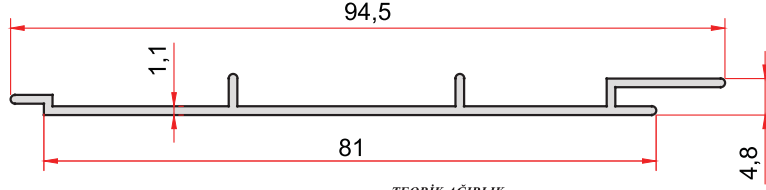

**KOD-CODE** *TEORİK AĞIRLIK*  
*THEORETICAL WEIGHT*  
**834** **0,351 Kg/m**

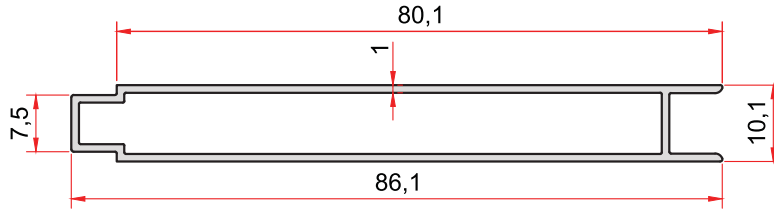

**KOD-CODE** *TEORİK AĞIRLIK*  
*THEORETICAL WEIGHT*  
**864** **0,510 Kg/m**

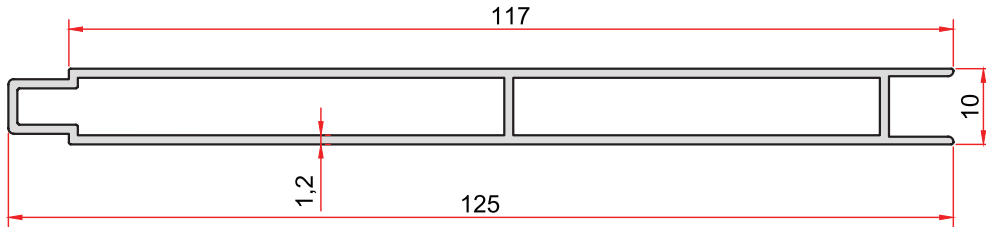

**KOD-CODE** *TEORİK AĞIRLIK*  
*THEORETICAL WEIGHT*  
**1149** **0,872 Kg/m**

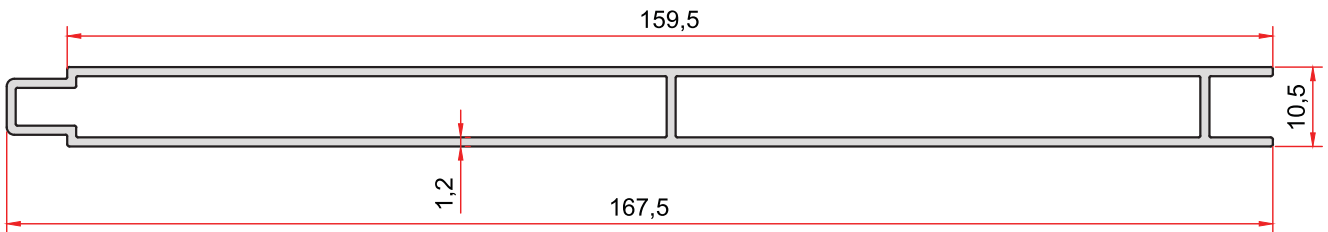

**KOD-CODE** *TEORİK AĞIRLIK*  
*THEORETICAL WEIGHT*  
**1203** **1,164 Kg/m**

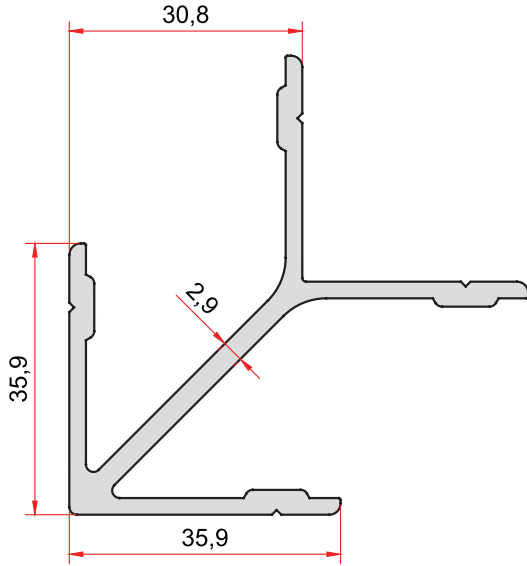

**KOD-CODE** *TEORİK AĞIRLIK*  
**839** *THEORETICAL WEIGHT*  
**1,172 Kg/m**

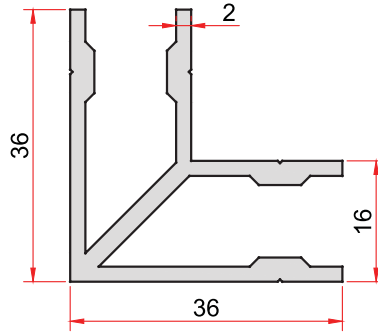

**KOD-CODE** *TEORİK AĞIRLIK*  
**840** *THEORETICAL WEIGHT*  
**0,807 Kg/m**

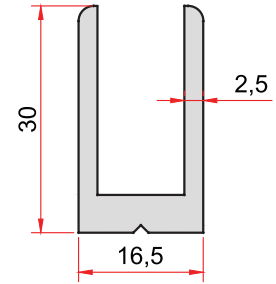

**KOD-CODE** *TEORİK AĞIRLIK*  
**841** *THEORETICAL WEIGHT*  
**0,553 Kg/m**

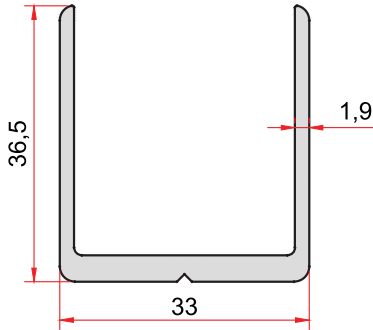

**KOD-CODE** *TEORİK AĞIRLIK*  
**842** *THEORETICAL WEIGHT*  
**0,640 Kg/m**

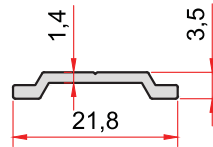

**KOD-CODE** *TEORİK AĞIRLIK*  
**836** *THEORETICAL WEIGHT*  
**0,097 Kg/m**

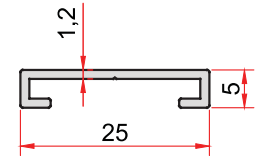

**KOD-CODE** *TEORİK AĞIRLIK*  
**837** *THEORETICAL WEIGHT*  
**0,124 Kg/m**

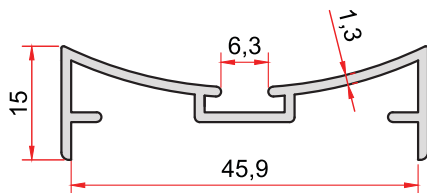

**KOD-CODE** *TEORİK AĞIRLIK*  
**878** *THEORETICAL WEIGHT*  
**0,335 Kg/m**

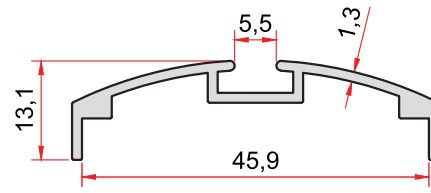

**KOD-CODE** *TEORİK AĞIRLIK*  
**863** *THEORETICAL WEIGHT*  
**0,310 Kg/m**

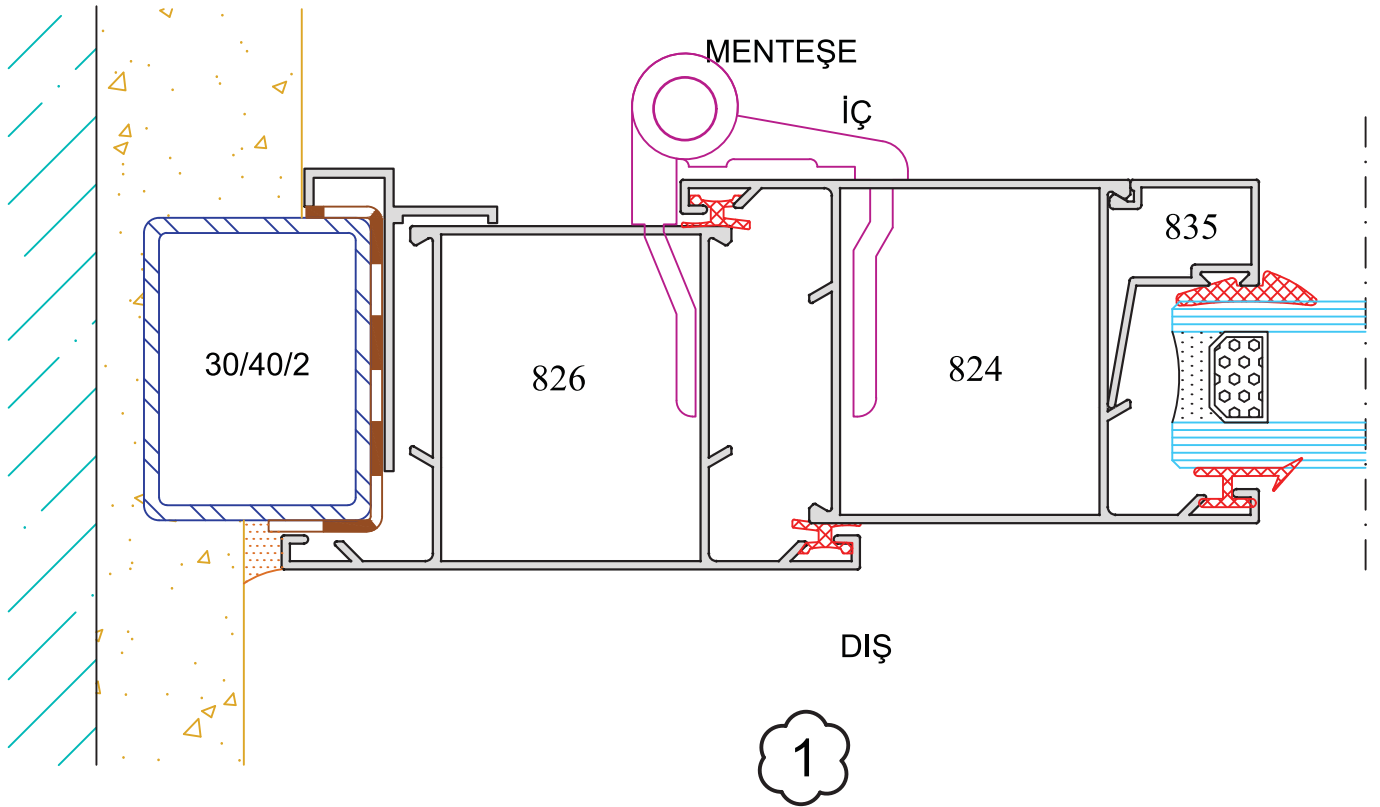
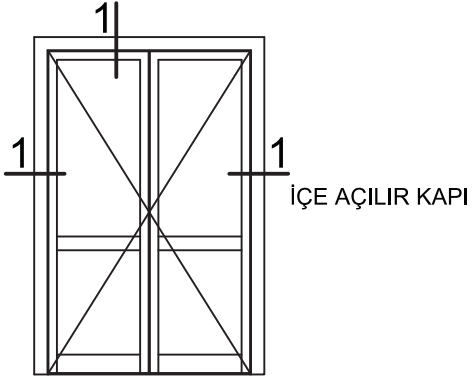

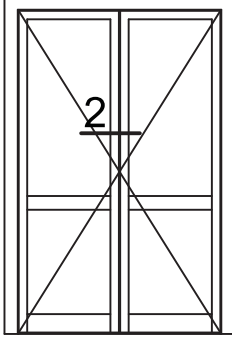

İÇE AÇILIR KAPI

2

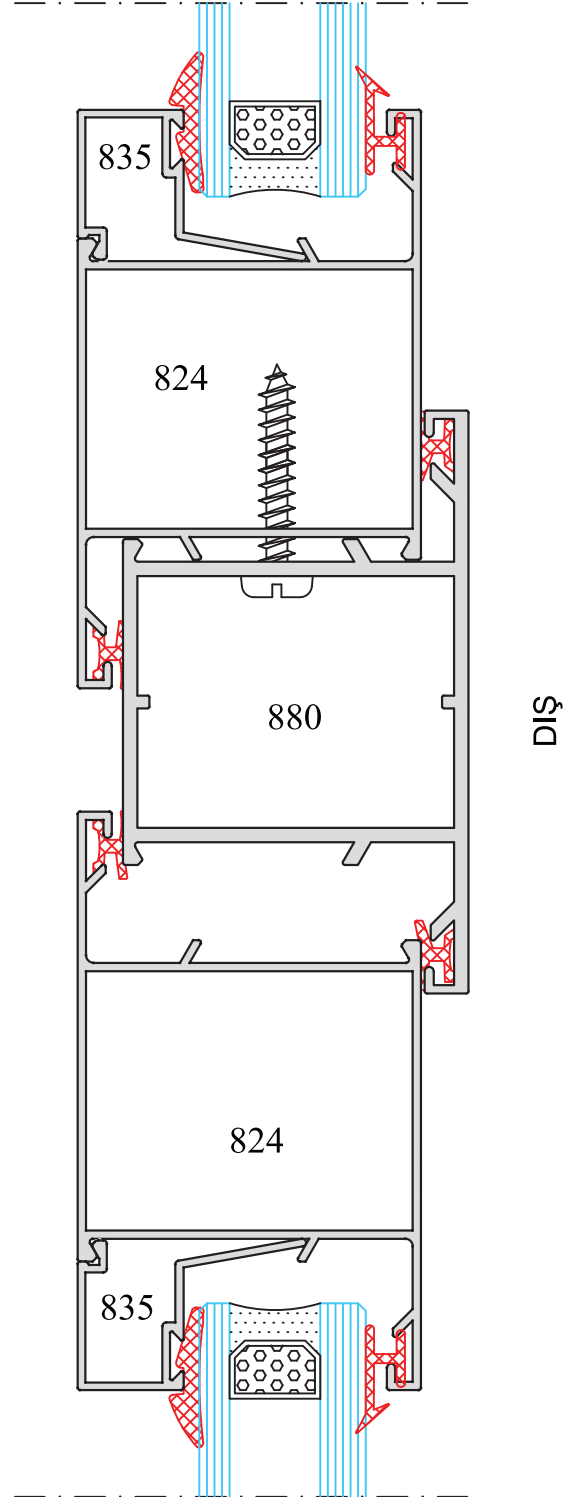



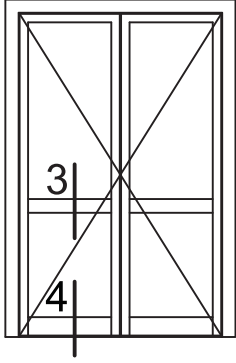

İÇE AÇILIR KAPI

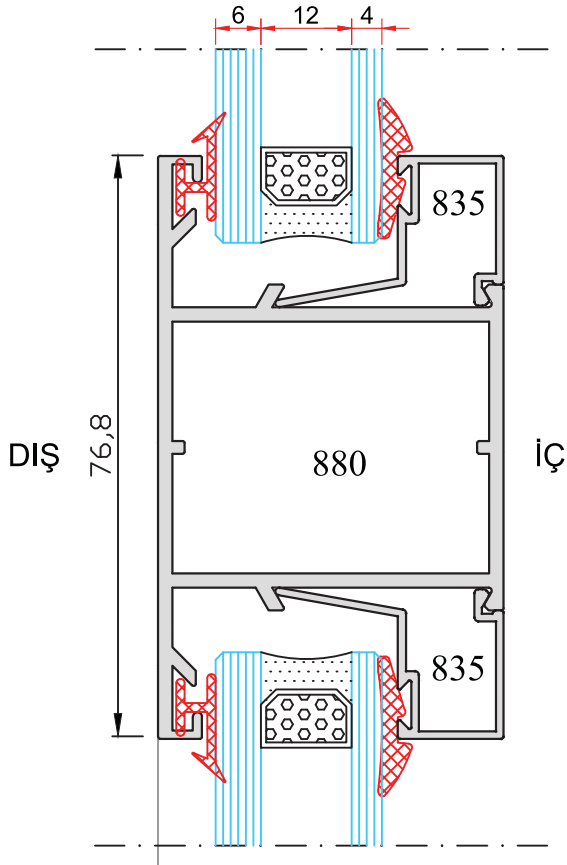

3

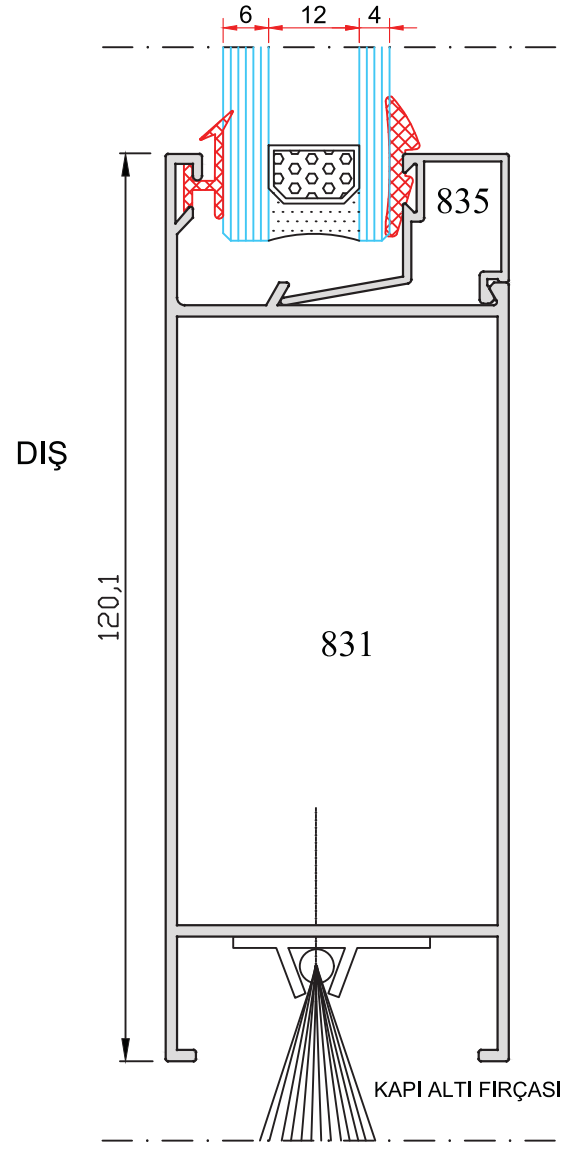

4

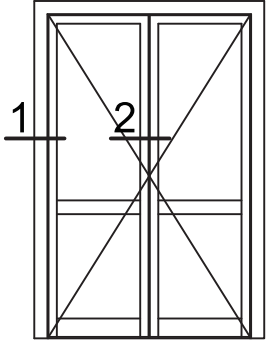

ÇARPMA KAPI

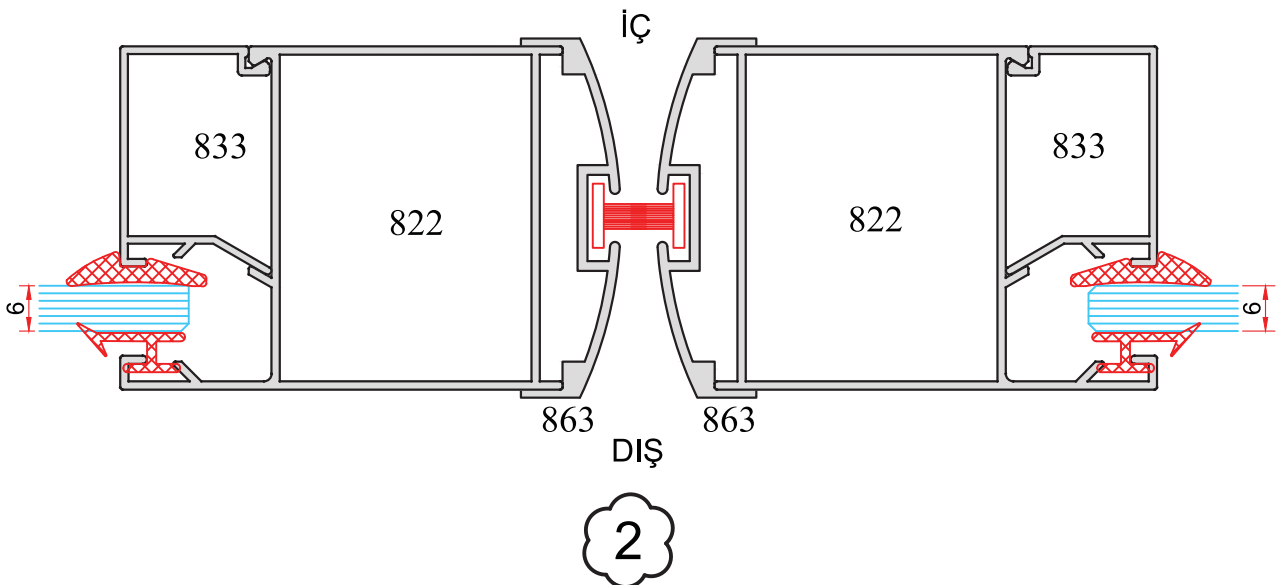
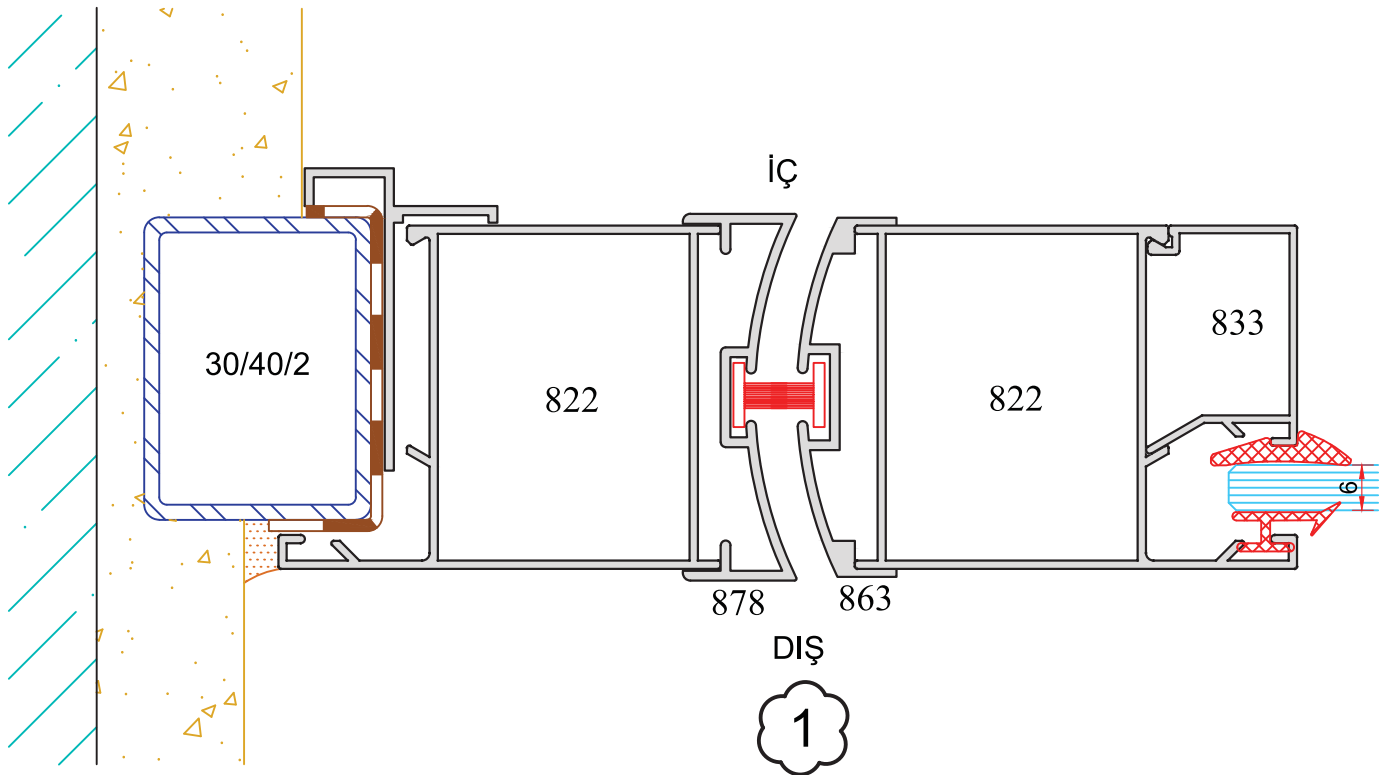

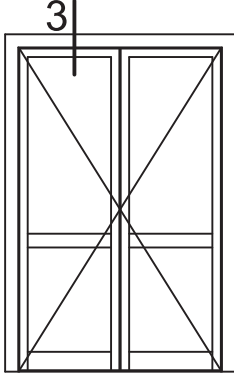

ÇARPMA KAPI

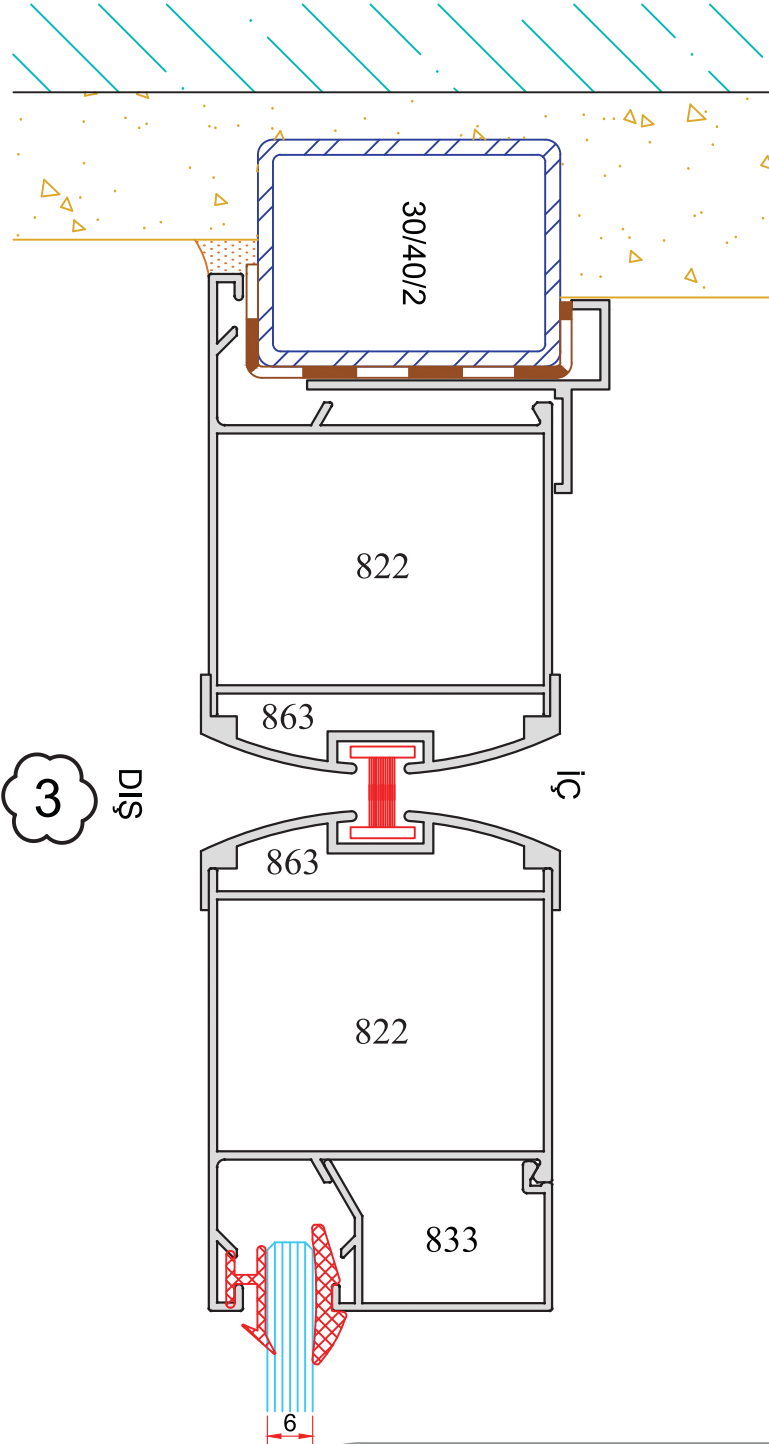

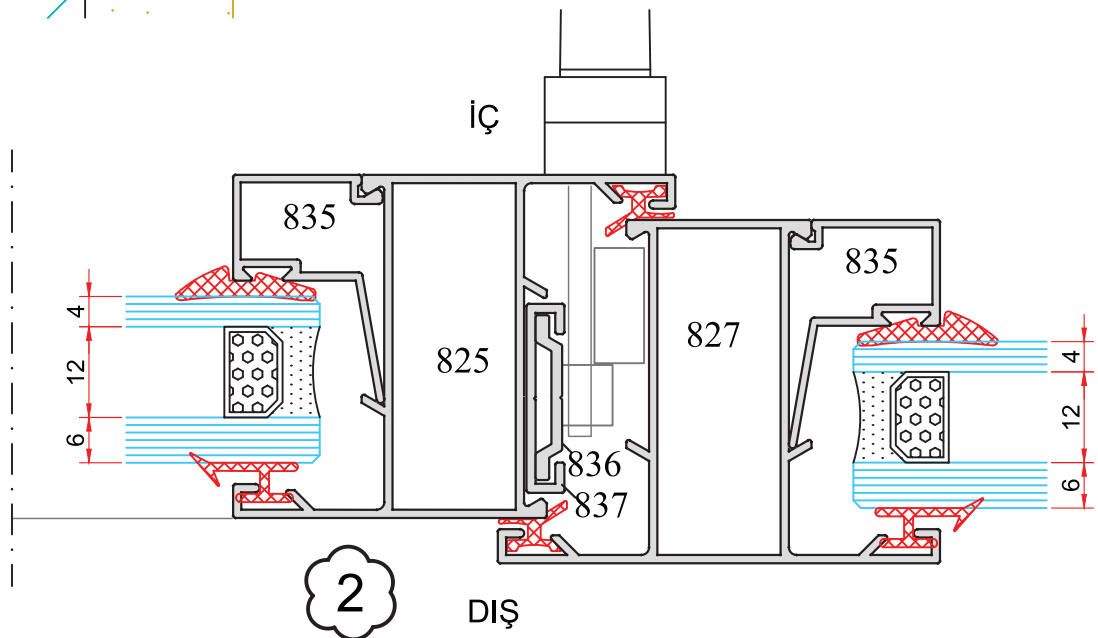
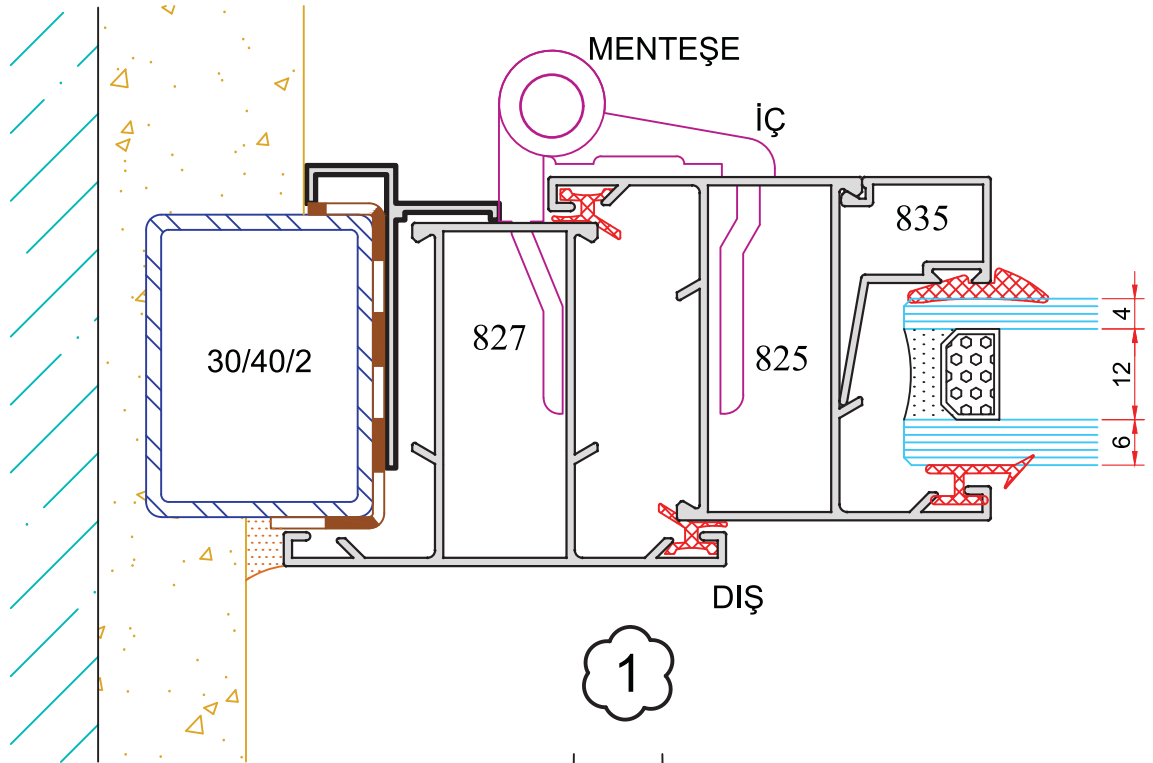
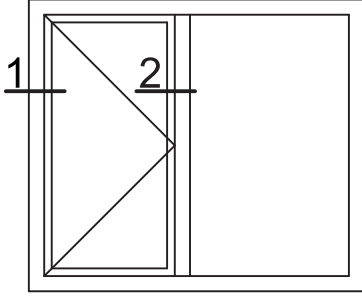

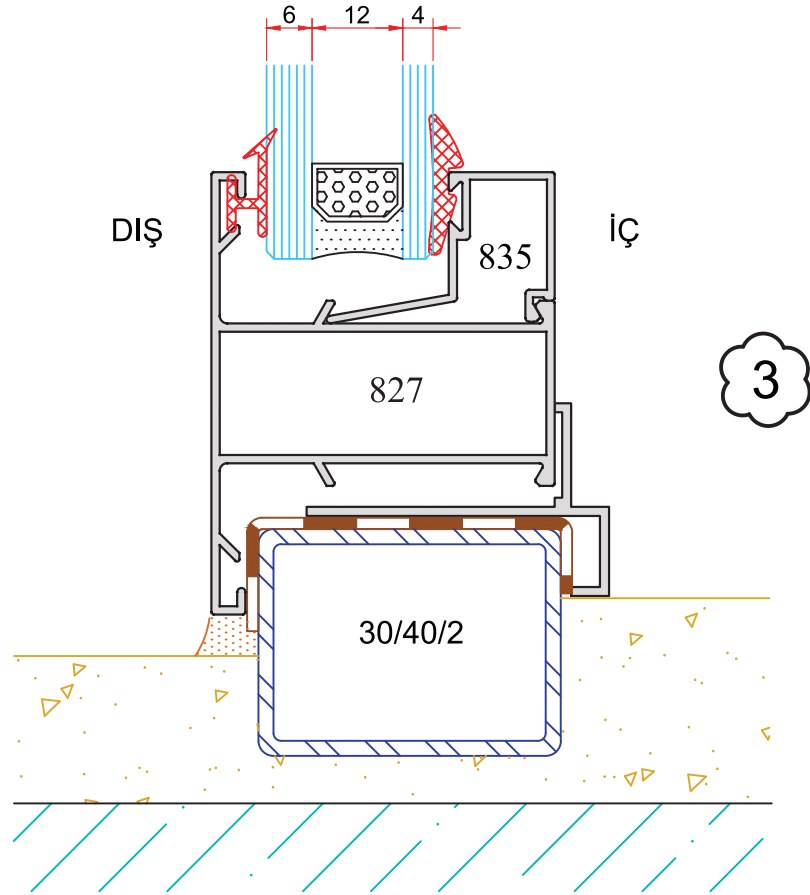
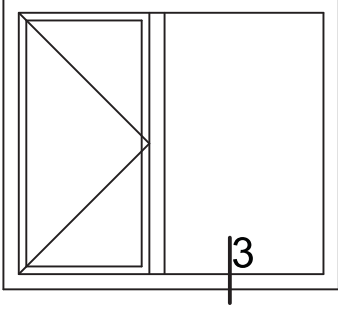

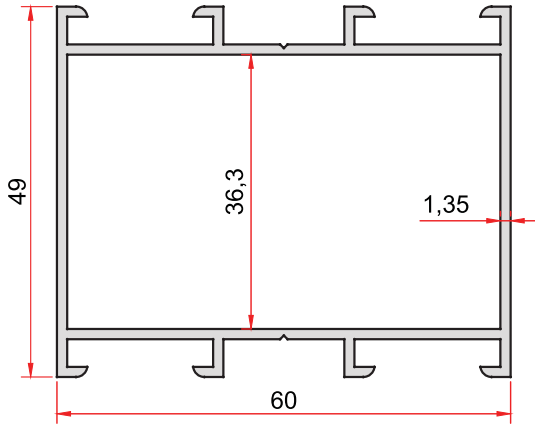

**KOD-CODE** *TEORİK AĞIRLIK*  
**844** *THEORETICAL WEIGHT*  
**0,913 Kg/m**

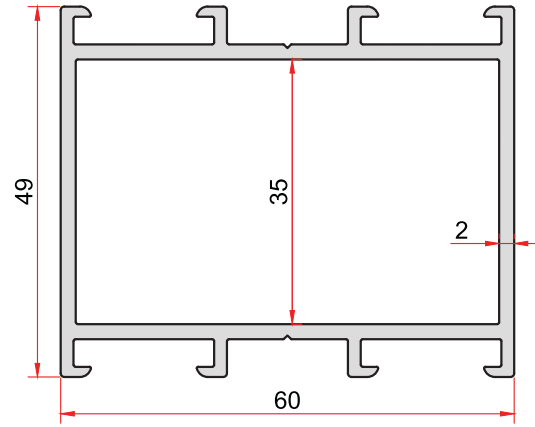

**KOD-CODE** *TEORİK AĞIRLIK*  
**1169** *THEORETICAL WEIGHT*  
**1,266 Kg/m**

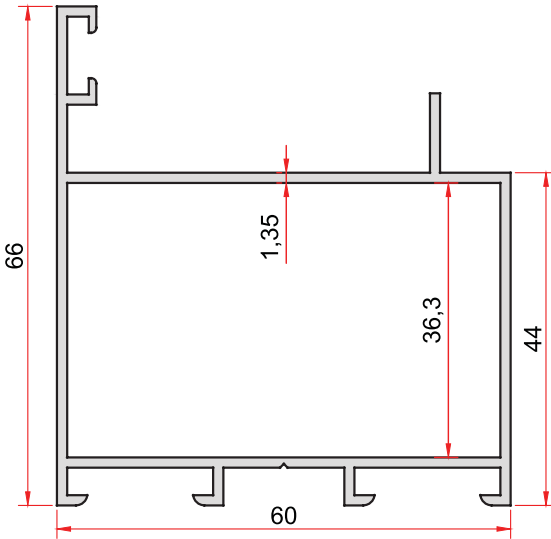

**KOD-CODE** *TEORİK AĞIRLIK*  
**845** *THEORETICAL WEIGHT*  
**0,967 Kg/m**

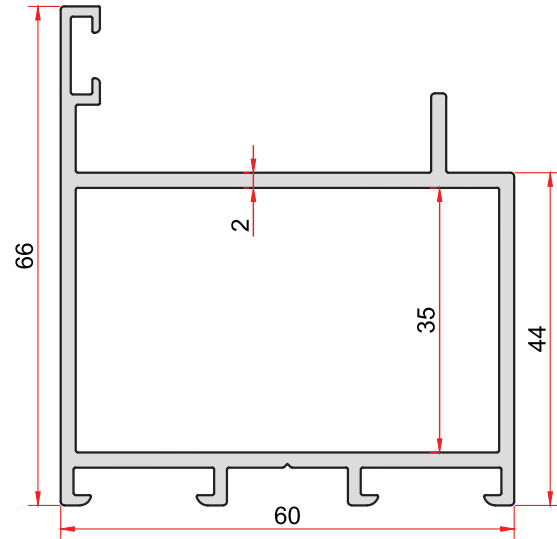

**KOD-CODE** *TEORİK AĞIRLIK*  
**1170** *THEORETICAL WEIGHT*  
**1,336 Kg/m**

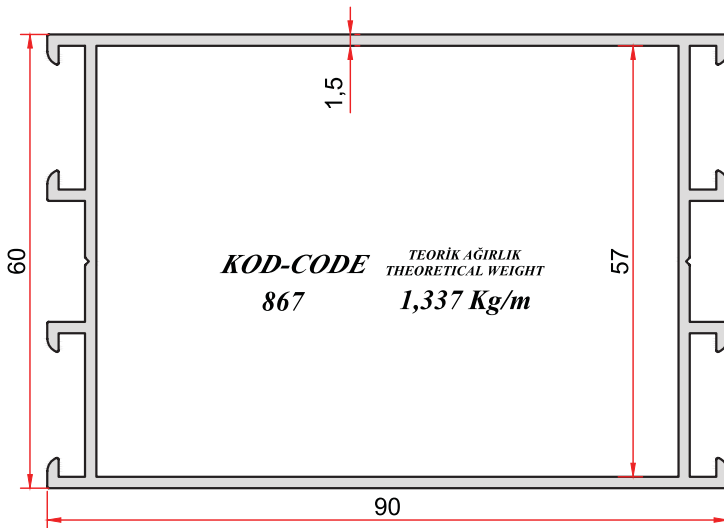

**KOD-CODE** *TEORİK AĞIRLIK*  
**867** *THEORETICAL WEIGHT*  
**1,337 Kg/m**

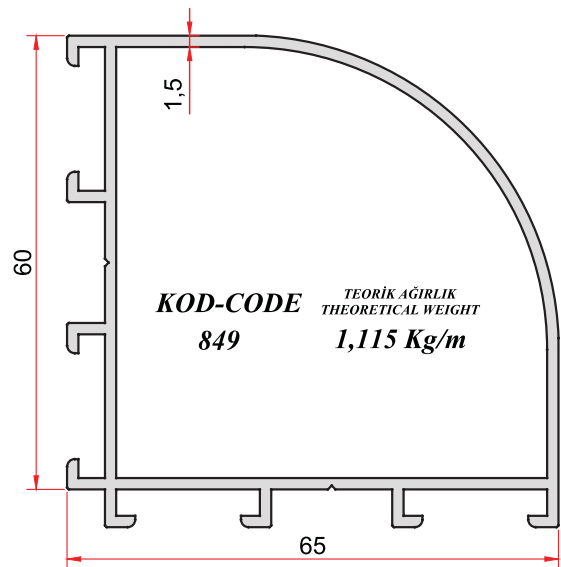

**KOD-CODE** *TEORİK AĞIRLIK*  
**849** *THEORETICAL WEIGHT*  
**1,115 Kg/m**



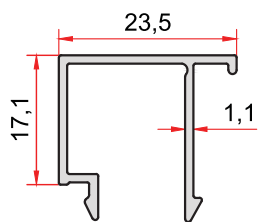
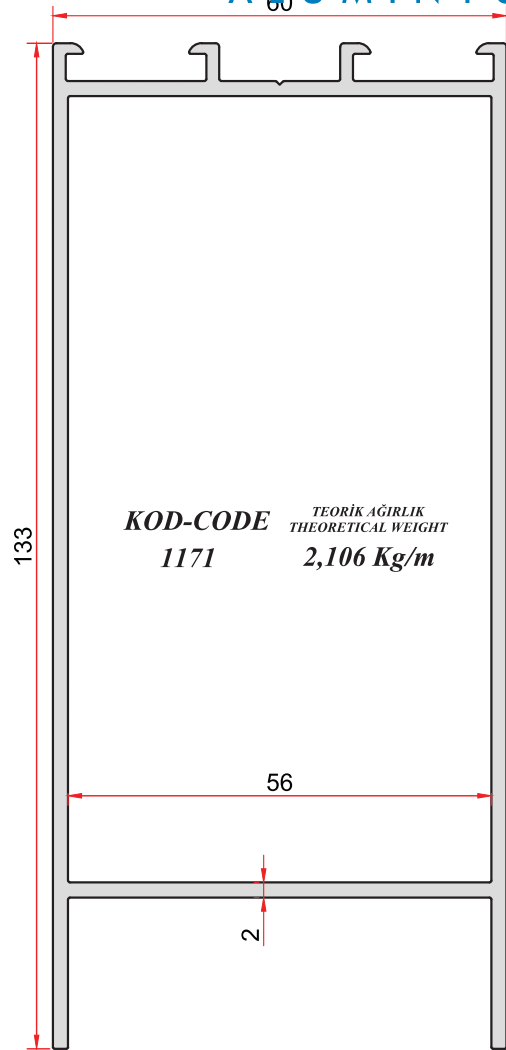
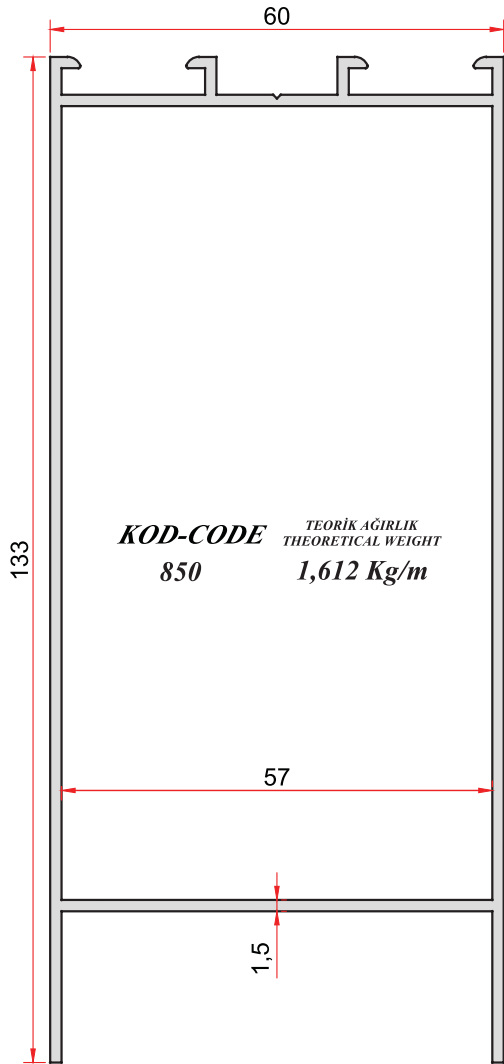

**KOD-CODE** *TEORİK AĞIRLIK*  
*THEORETICAL WEIGHT*  
**846** **0,216 Kg/m**

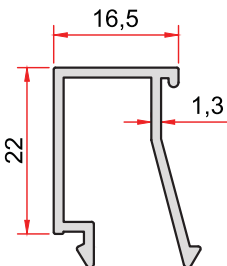

**KOD-CODE** *TEORİK AĞIRLIK*  
*THEORETICAL WEIGHT*  
**847** **0,262 Kg/m**

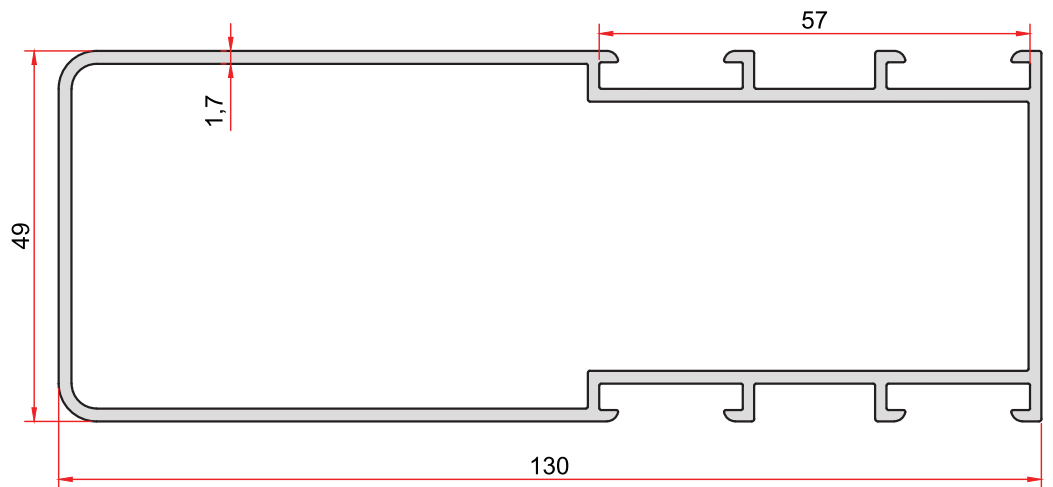

**KOD-CODE** *TEORİK AĞIRLIK*  
*THEORETICAL WEIGHT*  
**1188** **1,782 Kg/m**

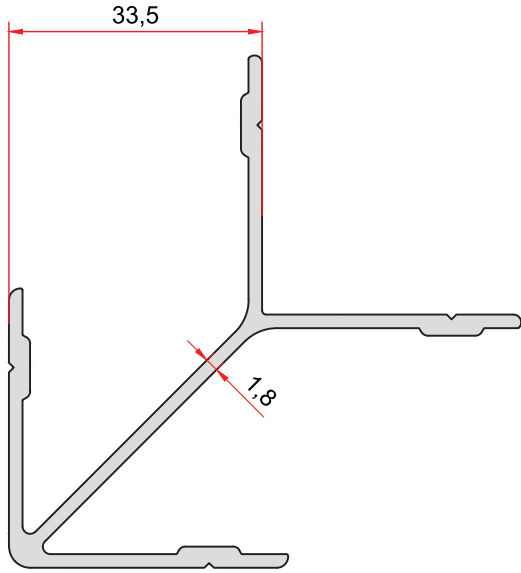

**KOD-CODE** *TEORİK AĞIRLIK*  
*THEORETICAL WEIGHT*  
**7027** **0,980 Kg/m**

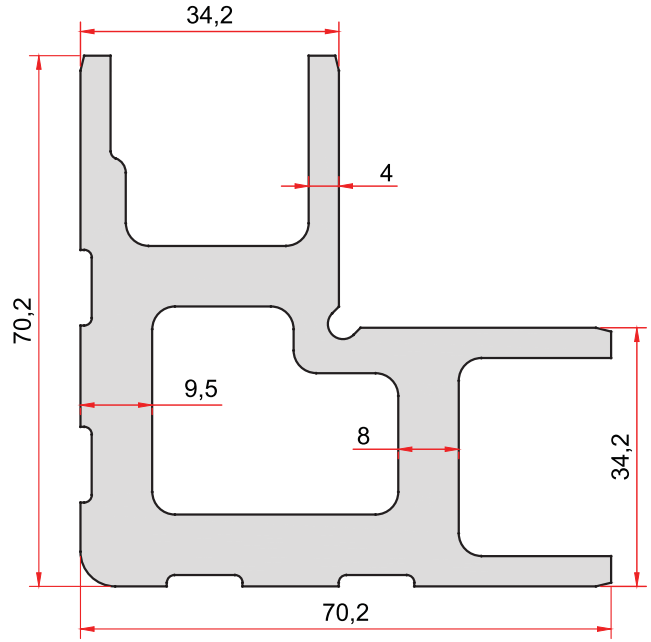

**KOD-CODE** *TEORİK AĞIRLIK*  
*THEORETICAL WEIGHT*  
**843** **4,417 Kg/m**

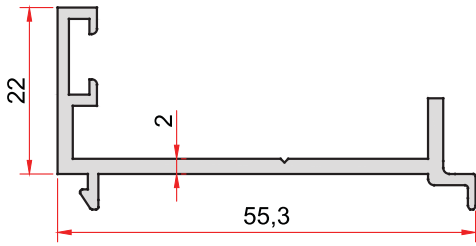

**KOD-CODE** *TEORİK AĞIRLIK*  
*THEORETICAL WEIGHT*  
**848** **0,502 Kg/m**

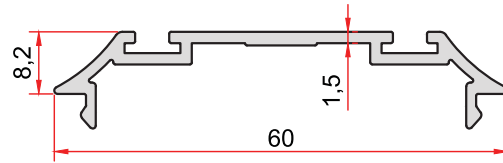

**KOD-CODE** *TEORİK AĞIRLIK*  
*THEORETICAL WEIGHT*  
**1240** **0,386 Kg/m**

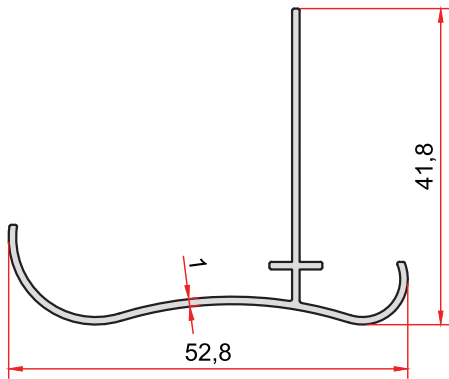

**KOD-CODE** *TEORİK AĞIRLIK*  
*THEORETICAL WEIGHT*  
**1242** **0,297 Kg/m**

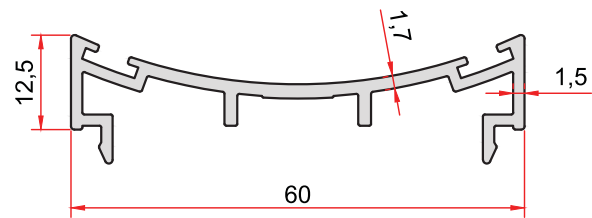

**KOD-CODE** *TEORİK AĞIRLIK*  
*THEORETICAL WEIGHT*  
**1243** **0,510 Kg/m**

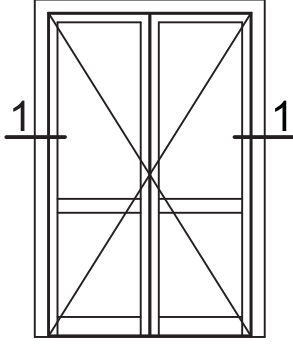

İÇE AÇILIR KAPI  
DOOR - INSIDE OPENING

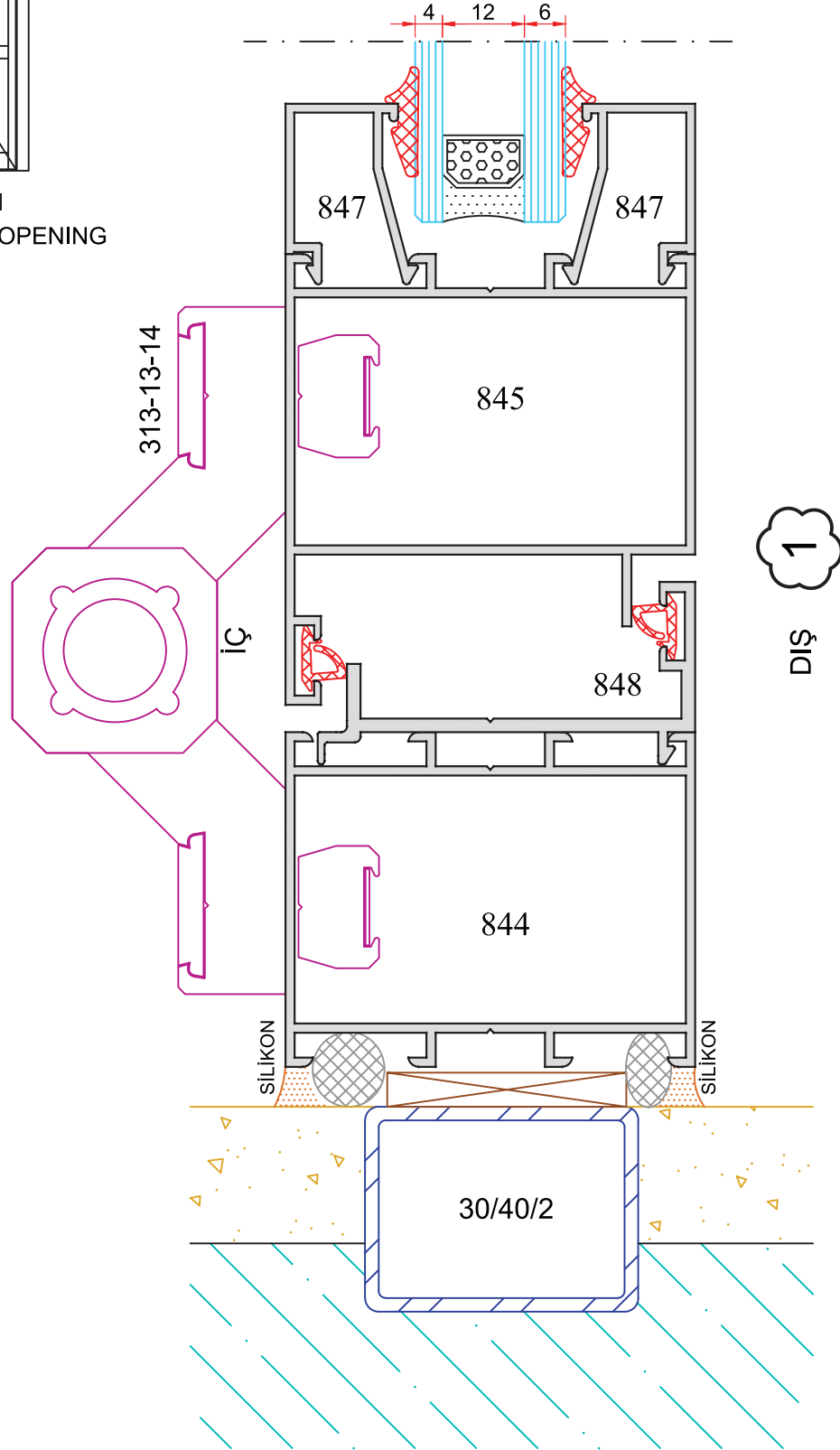

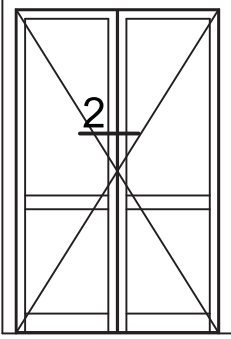

İÇE AÇILIR KAPI  
DOOR - INSIDE OPENING

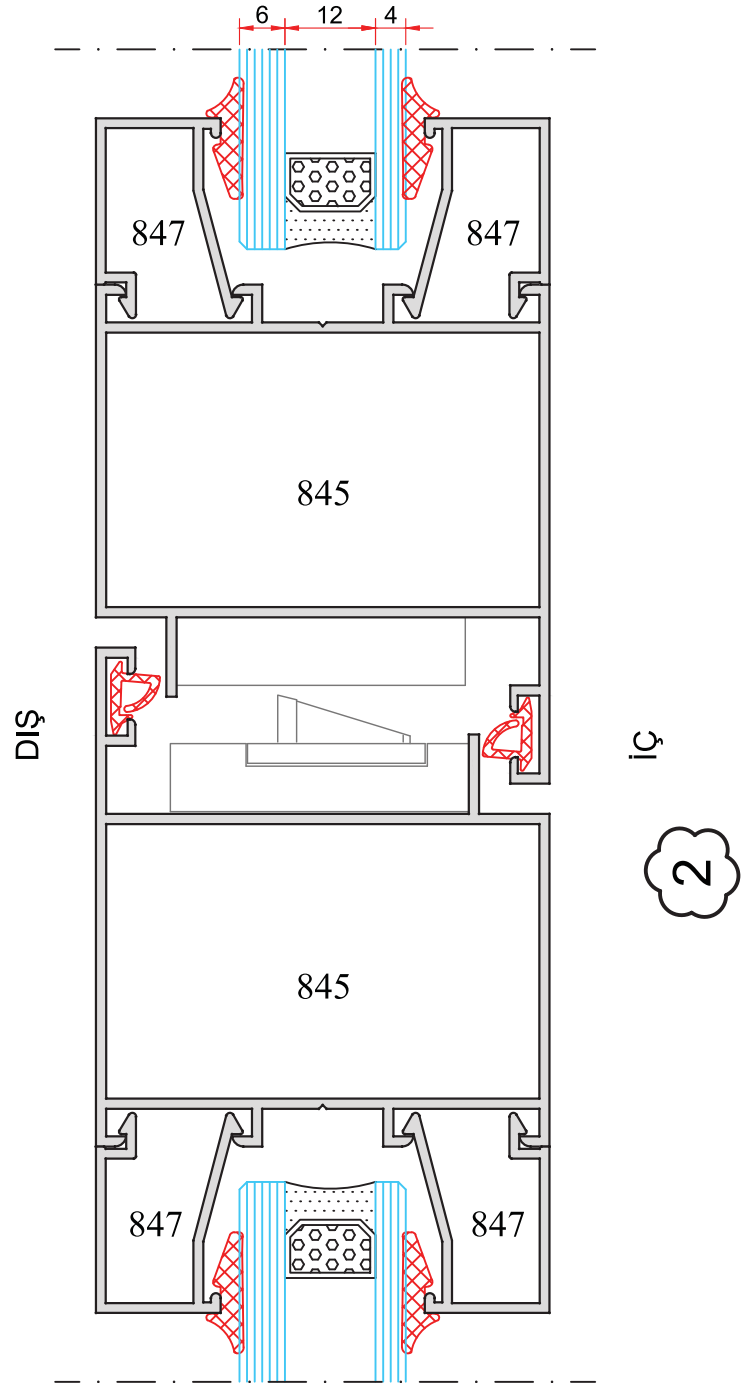

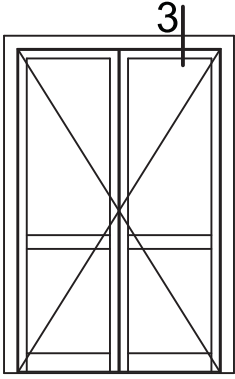

İÇE AÇILIR KAPI  
DOOR - INSIDE OPENING

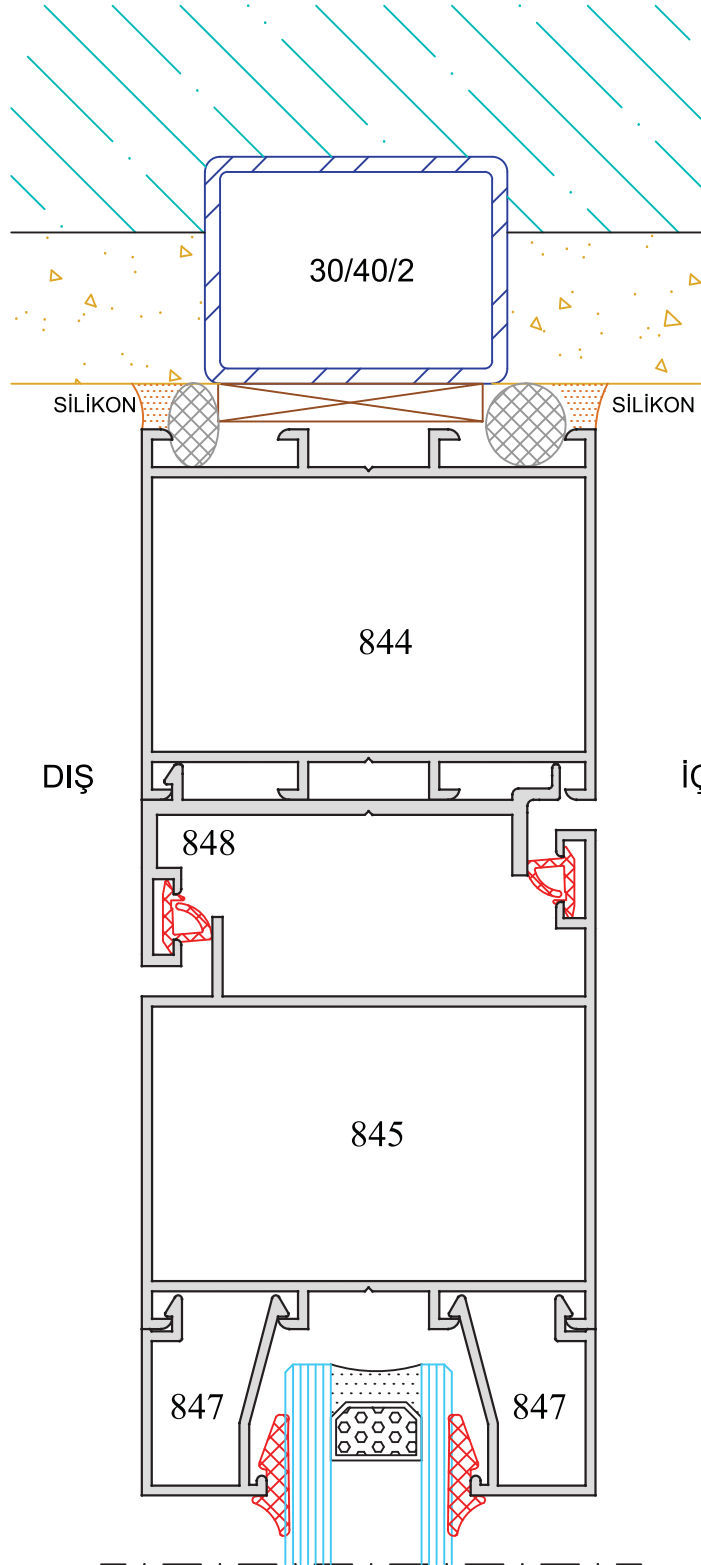

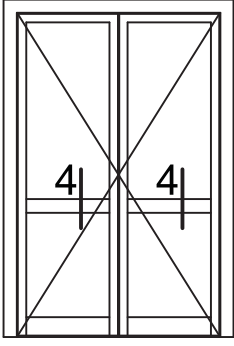

İÇE AÇILIR KAPI  
DOOR - INSIDE OPENING

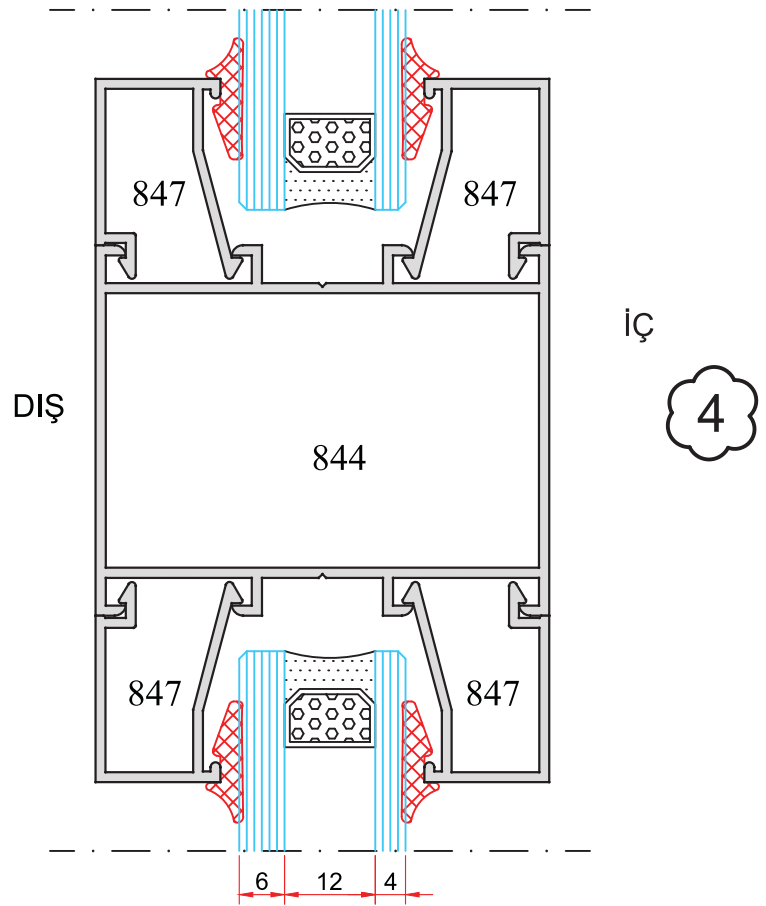



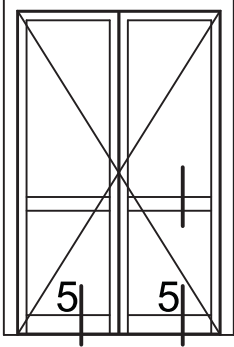

İÇE AÇILIR KAPI  
DOOR - INSIDE OPENING

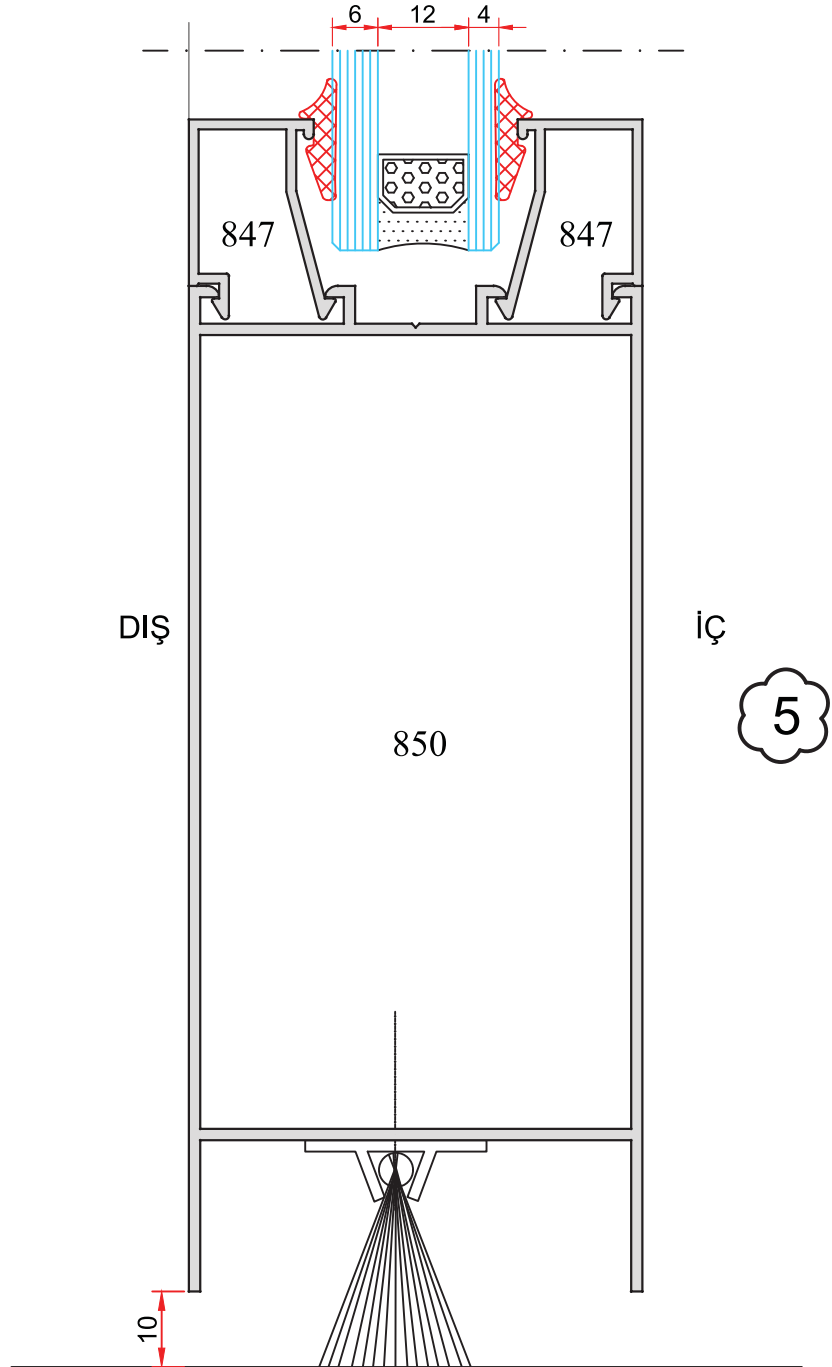

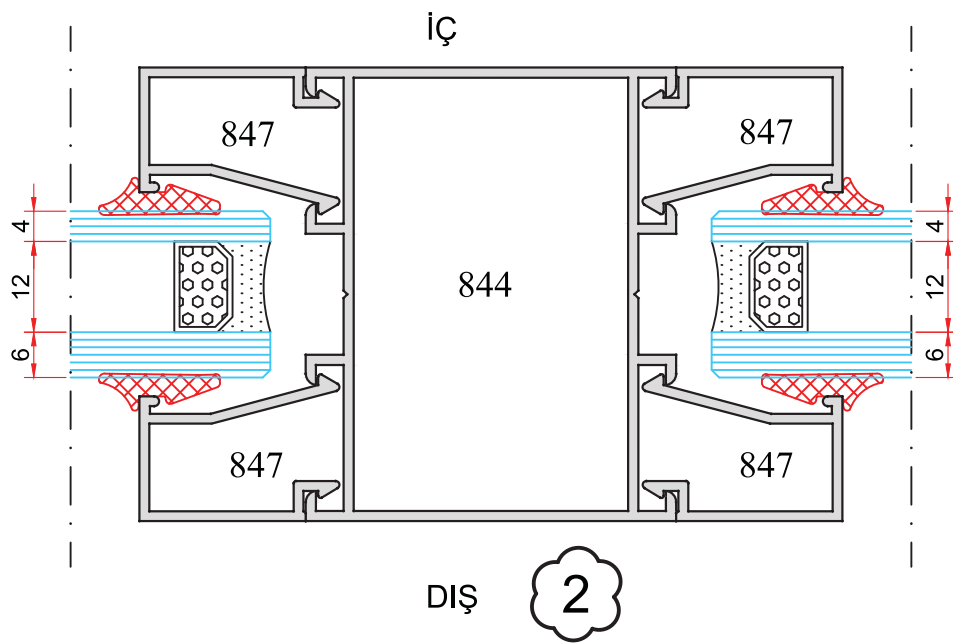
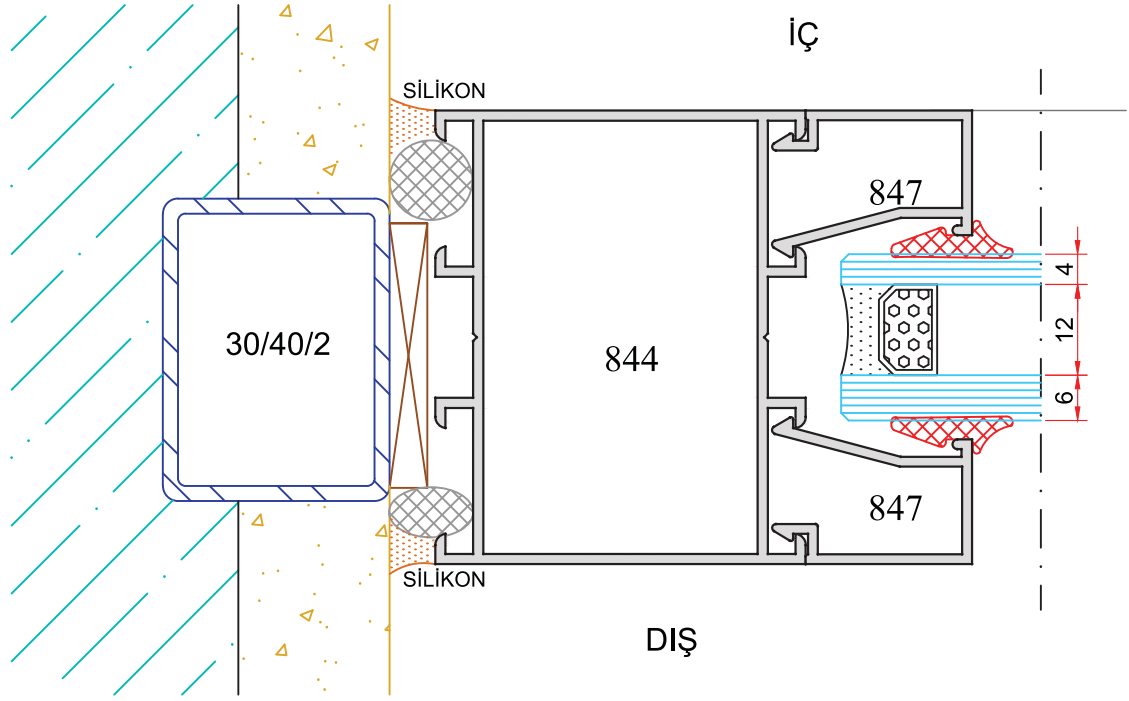
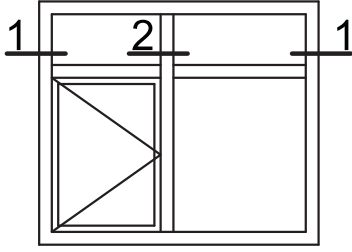

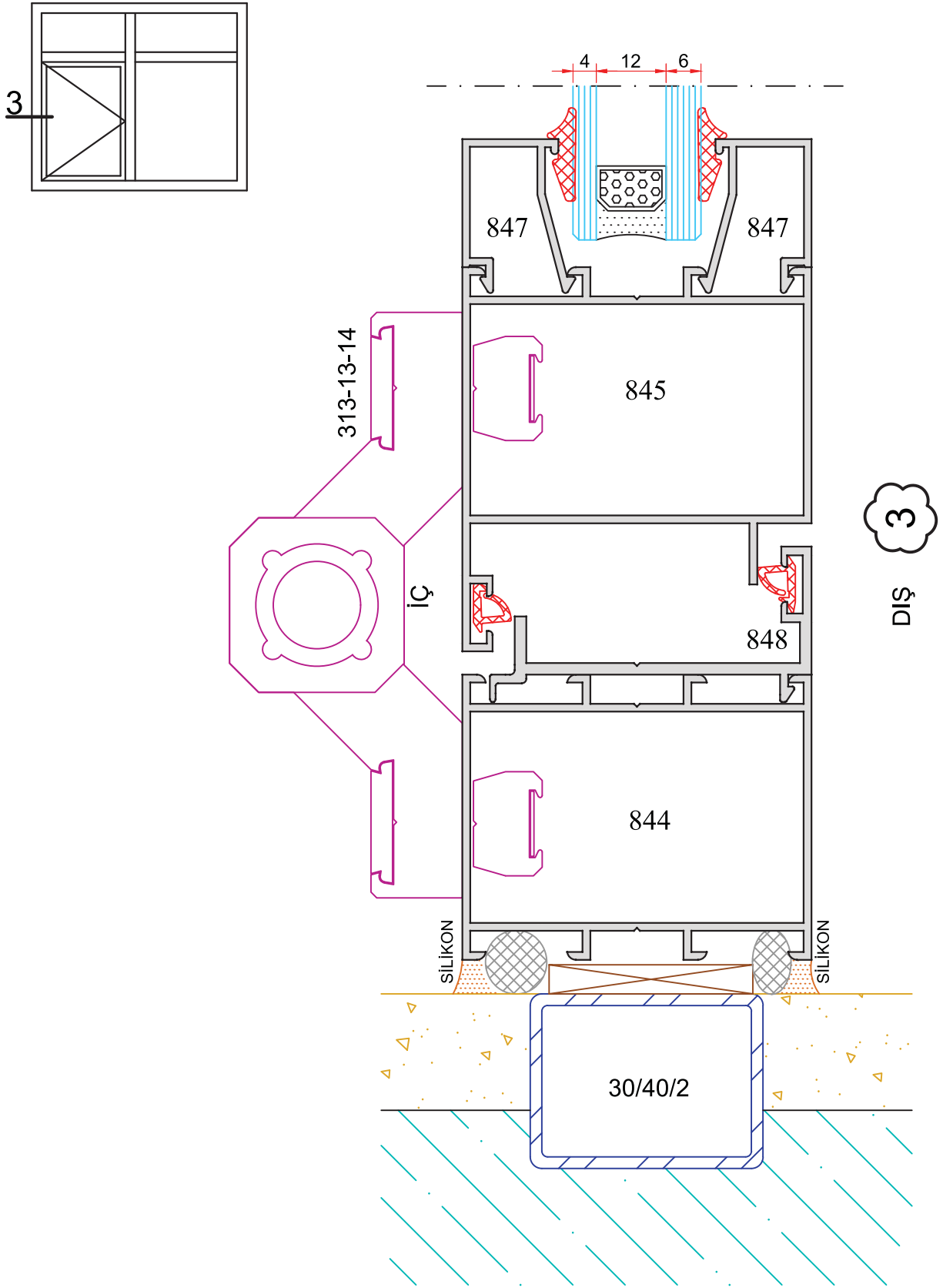

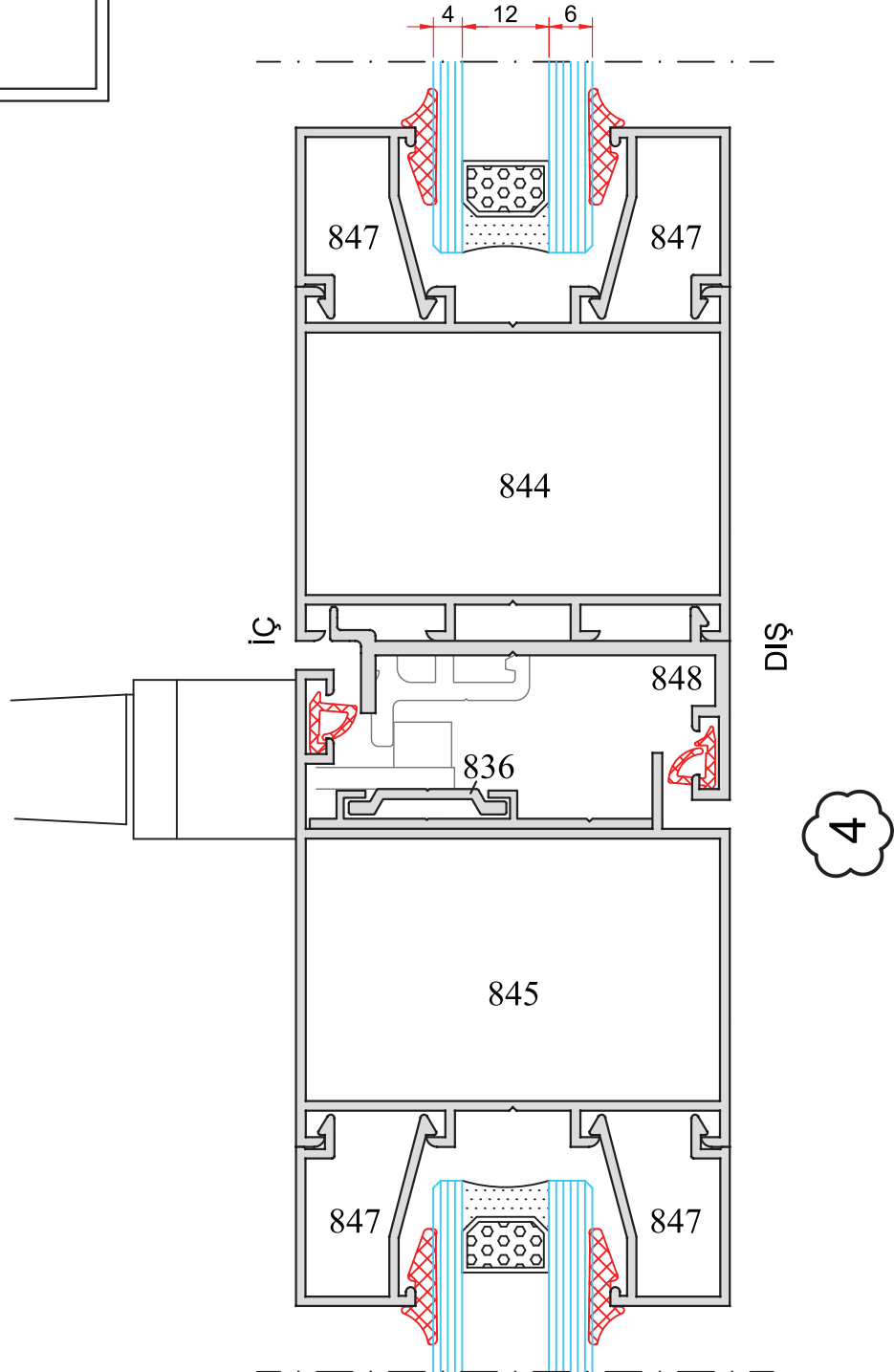
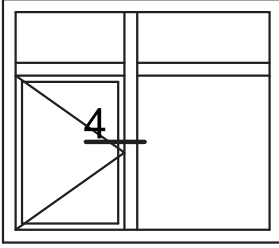

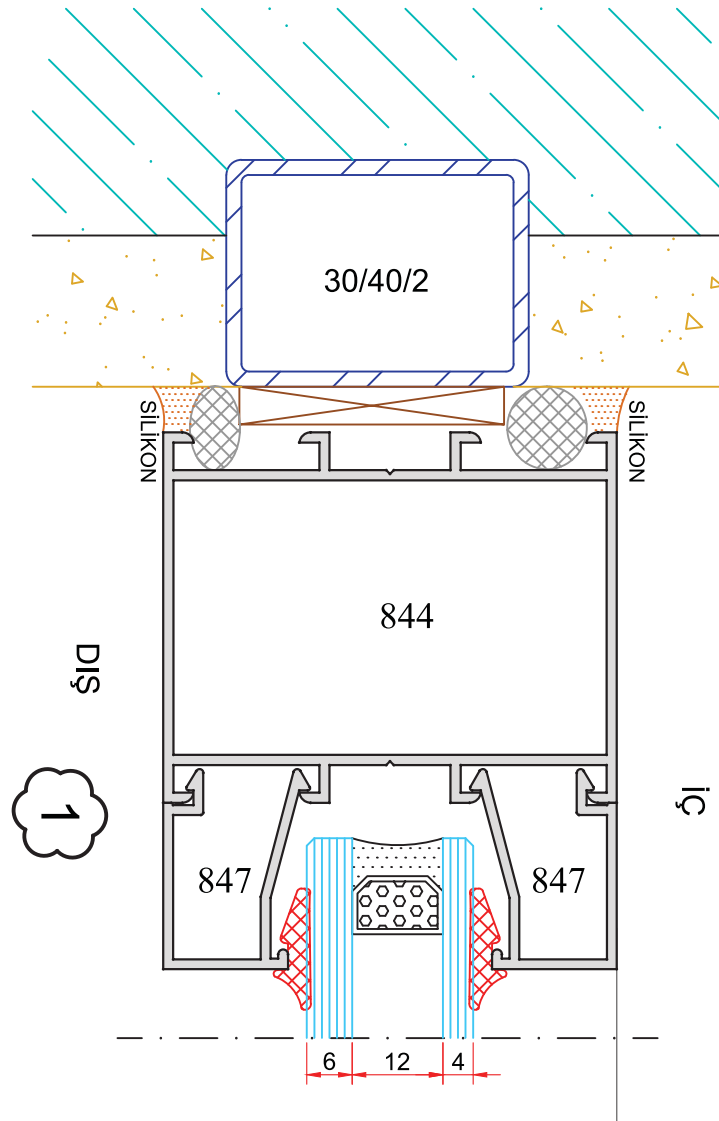
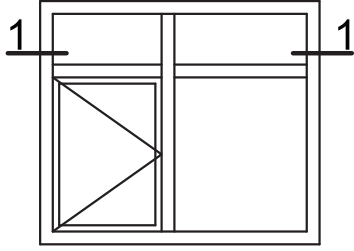

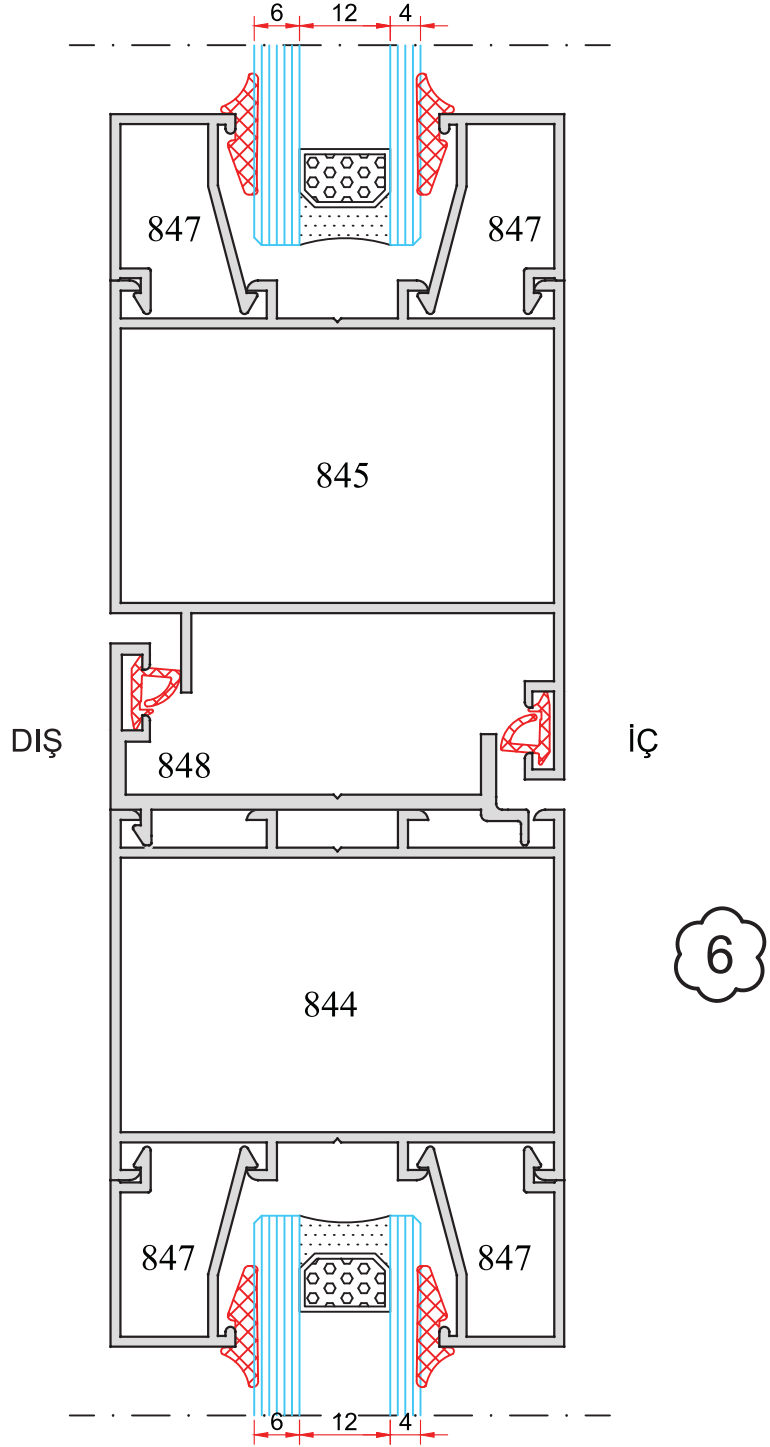
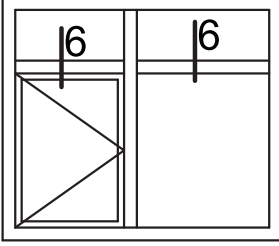

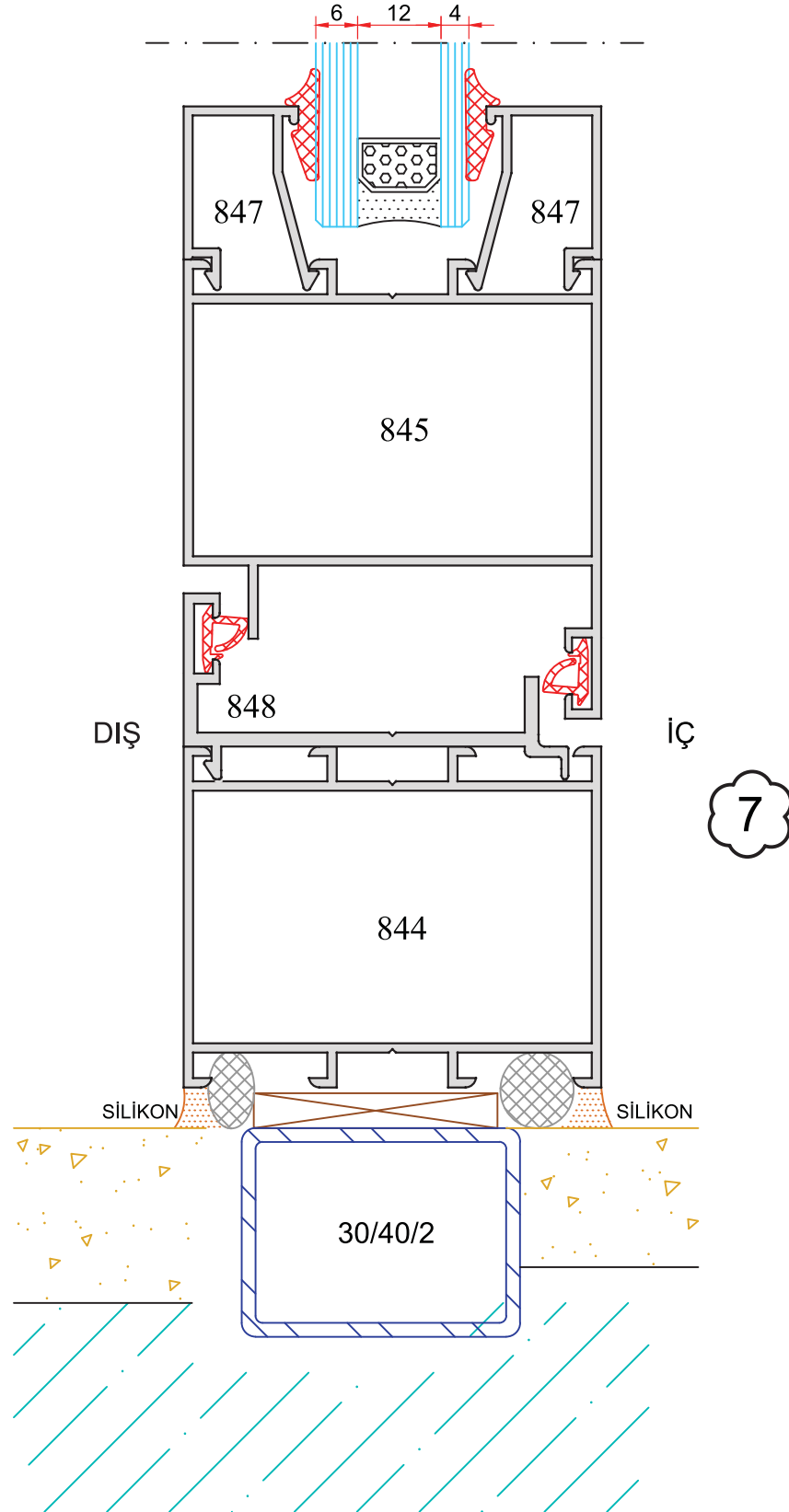
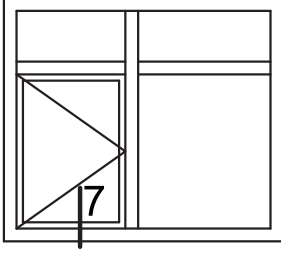



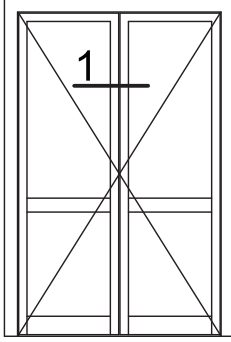

TAKVİYELİ KASA ve ORTA KAYIT

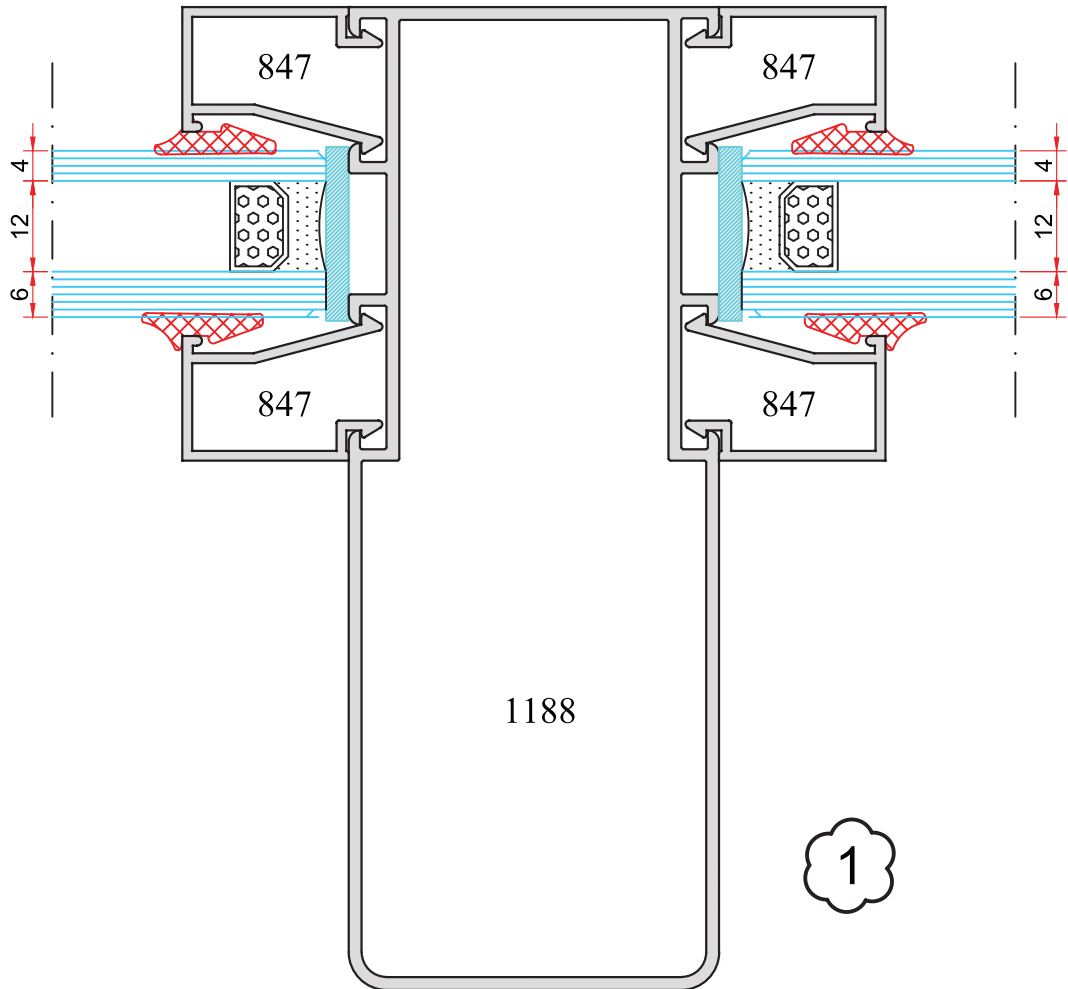

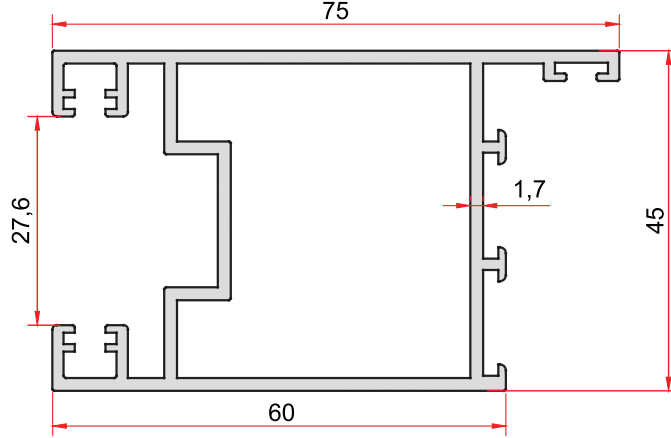

**KOD-CODE**      **TEORİK AĞIRLIK**  
**807**              **THEORETICAL WEIGHT**  
                         **1,280 Kg/m**

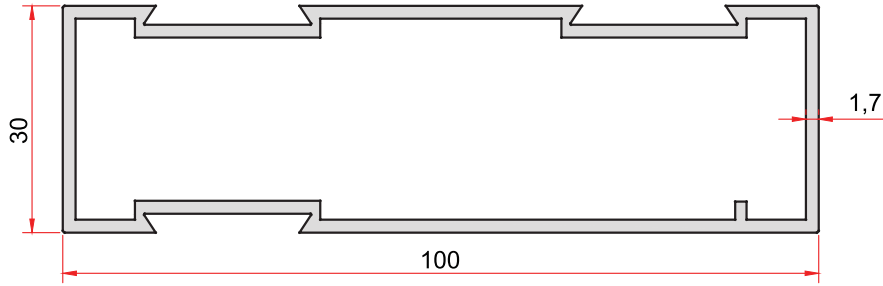

**KOD-CODE**      **TEORİK AĞIRLIK**  
**808**              **THEORETICAL WEIGHT**  
                         **1,253 Kg/m**

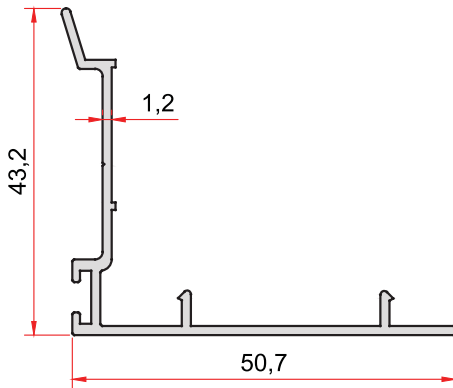

**KOD-CODE**      **TEORİK AĞIRLIK**  
**809**              **THEORETICAL WEIGHT**  
                         **0,370 Kg/m**

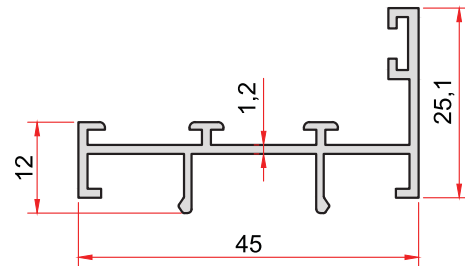

**KOD-CODE**      **TEORİK AĞIRLIK**  
**812**              **THEORETICAL WEIGHT**  
                         **0,383 Kg/m**

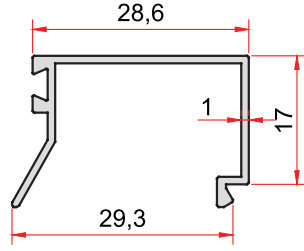

**KOD-CODE** *TEORİK AĞIRLIK*  
*THEORETICAL WEIGHT*  
**811** **0,213 Kg/m**

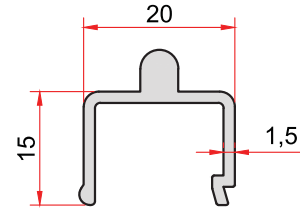

**KOD-CODE** *TEORİK AĞIRLIK*  
*THEORETICAL WEIGHT*  
**810** **0,262 Kg/m**

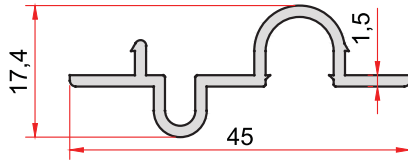

**KOD-CODE** *TEORİK AĞIRLIK*  
*THEORETICAL WEIGHT*  
**813** **0,302 Kg/m**

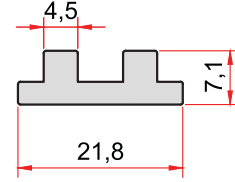

**KOD-CODE** *TEORİK AĞIRLIK*  
*THEORETICAL WEIGHT*  
**868** **0,275 Kg/m**

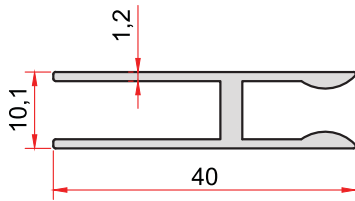

**KOD-CODE** *TEORİK AĞIRLIK*  
*THEORETICAL WEIGHT*  
**869** **0,340 Kg/m**

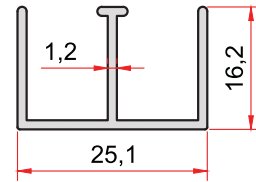

**KOD-CODE** *TEORİK AĞIRLIK*  
*THEORETICAL WEIGHT*  
**870** **0,235 Kg/m**

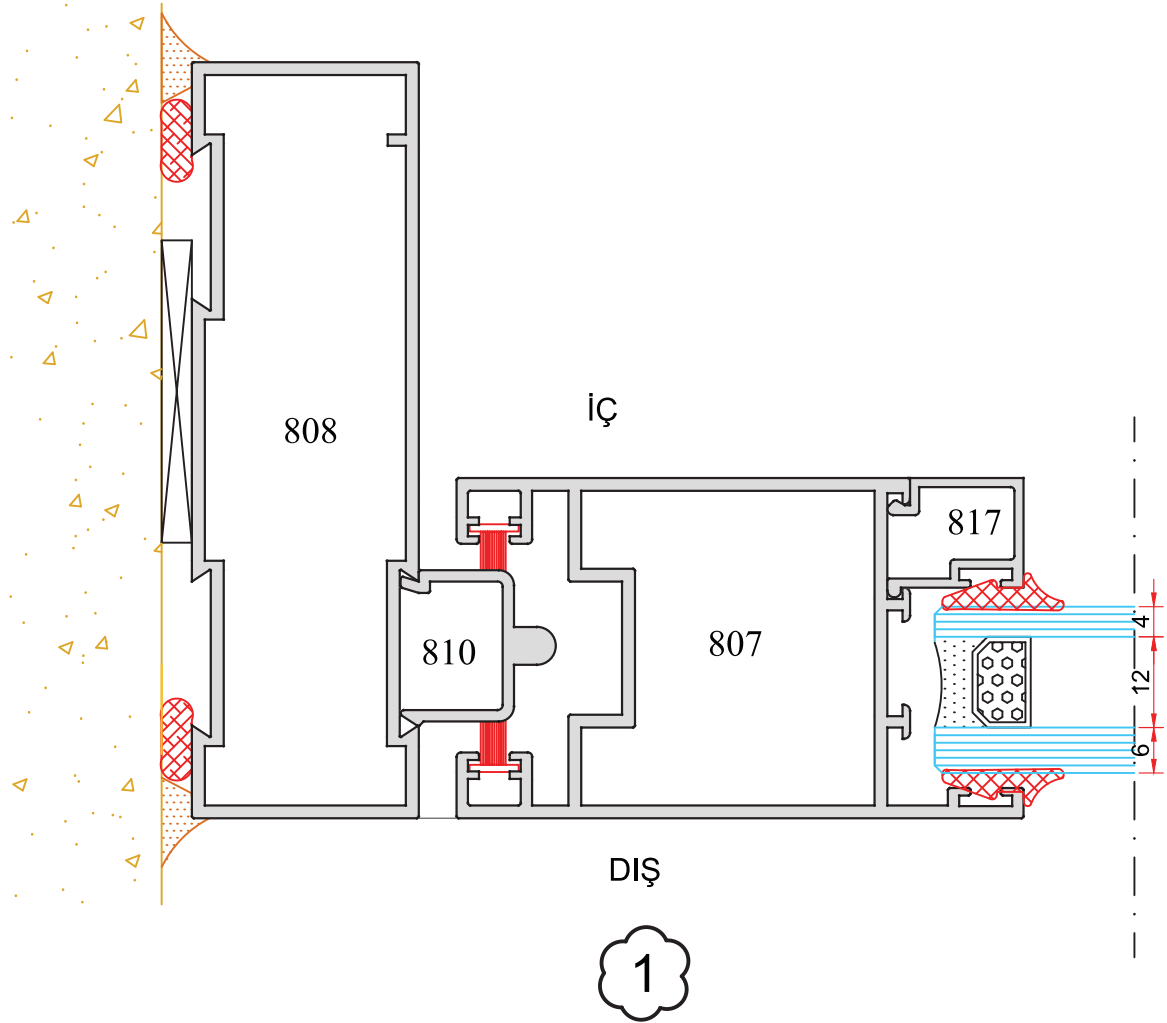
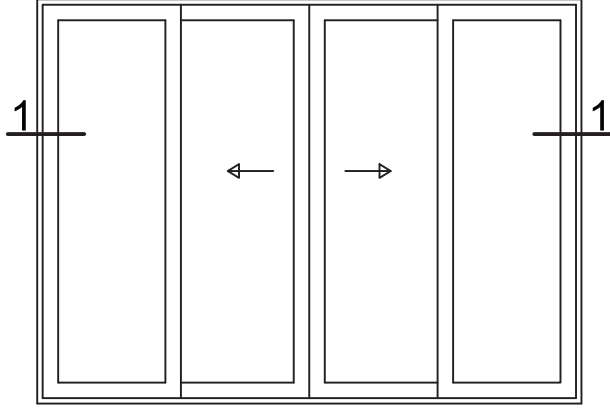

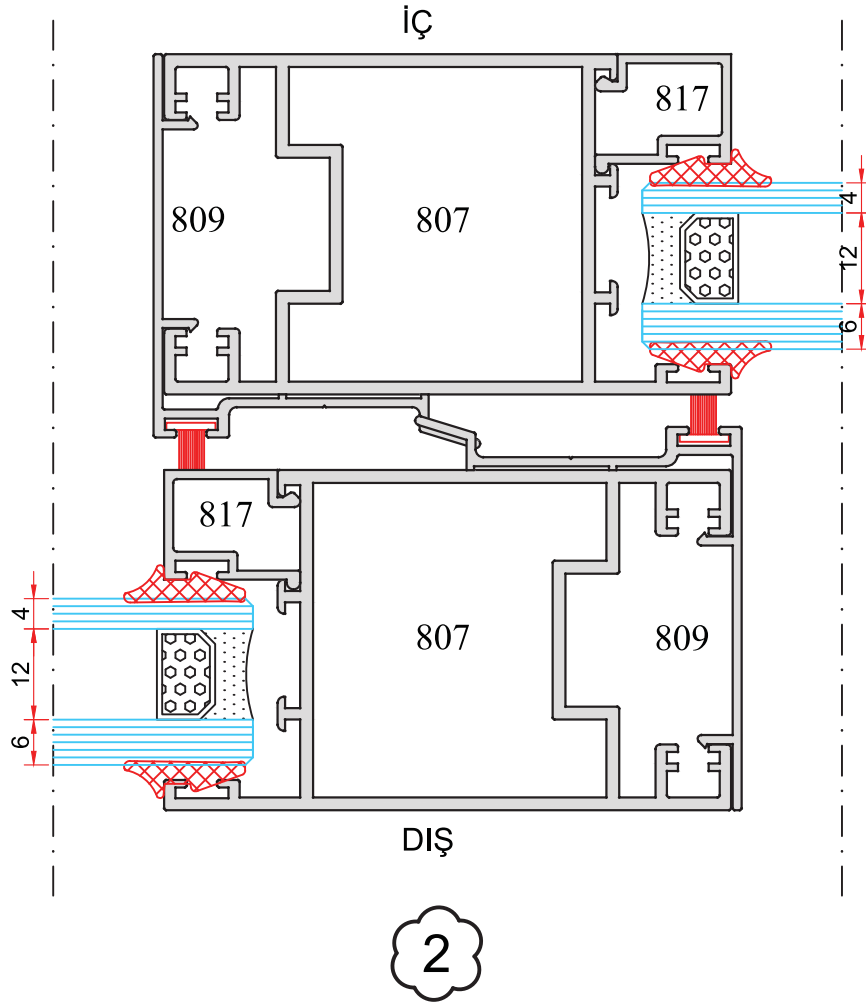
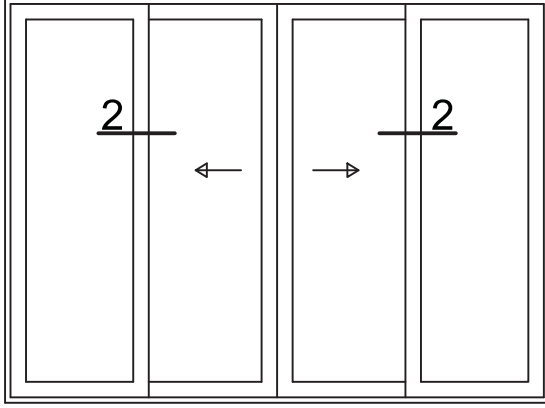

Doğrama Profilleri  
Tuğba Sürme - Büyük Seri

ARFEM®  
ALÜMİNYUM

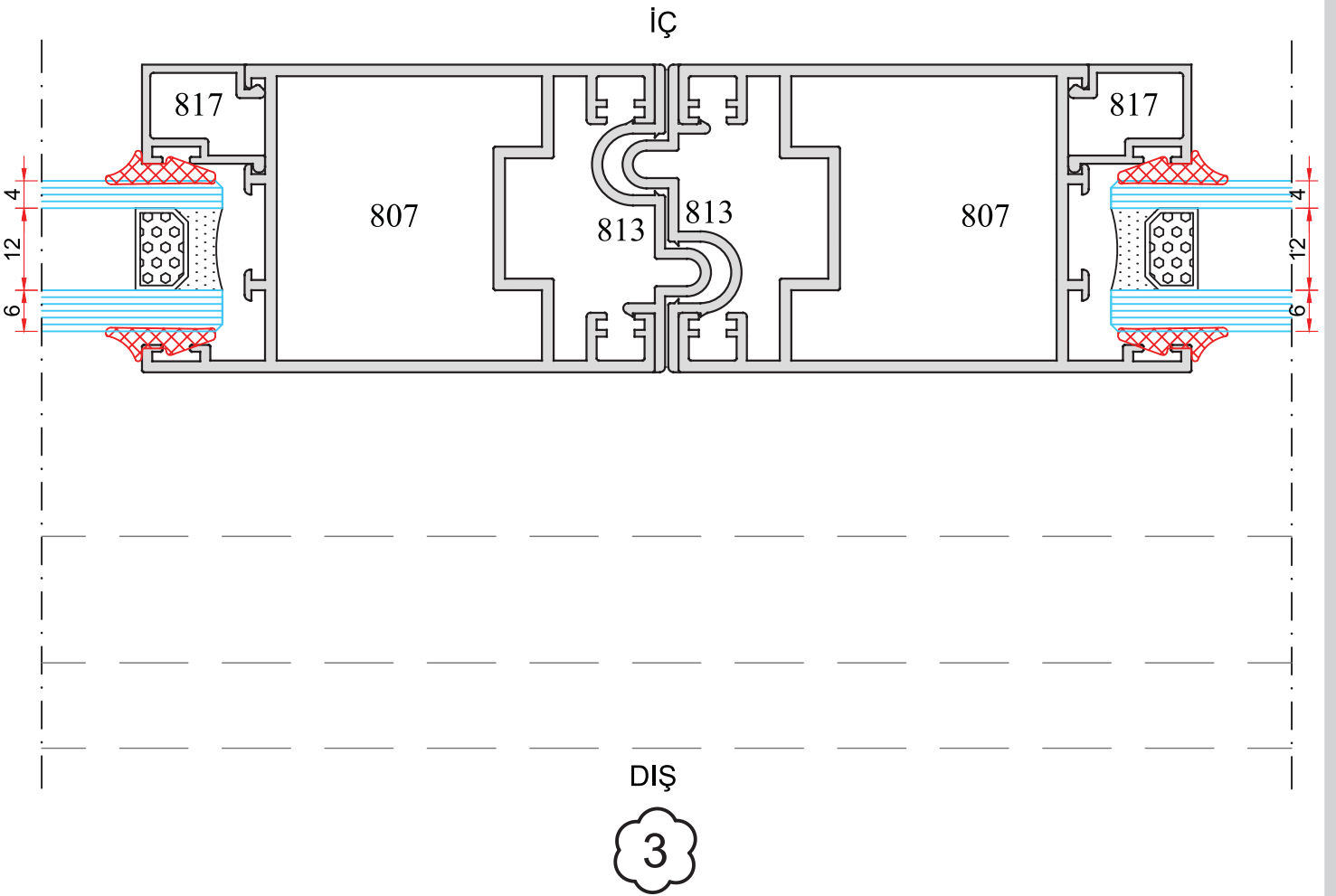
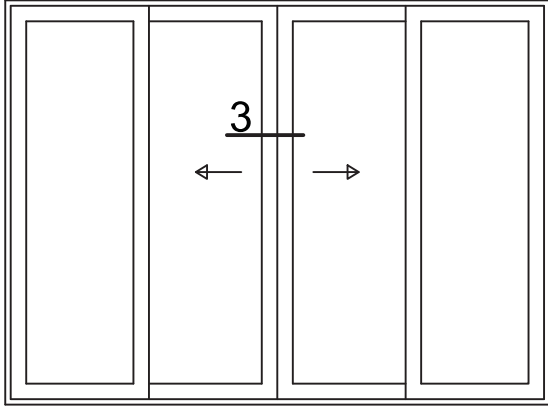

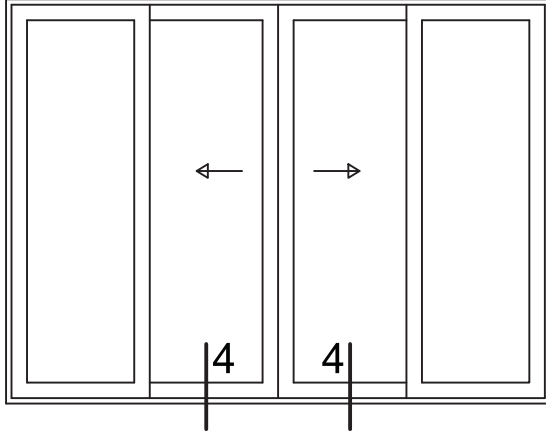

4

DIŞ

İÇ

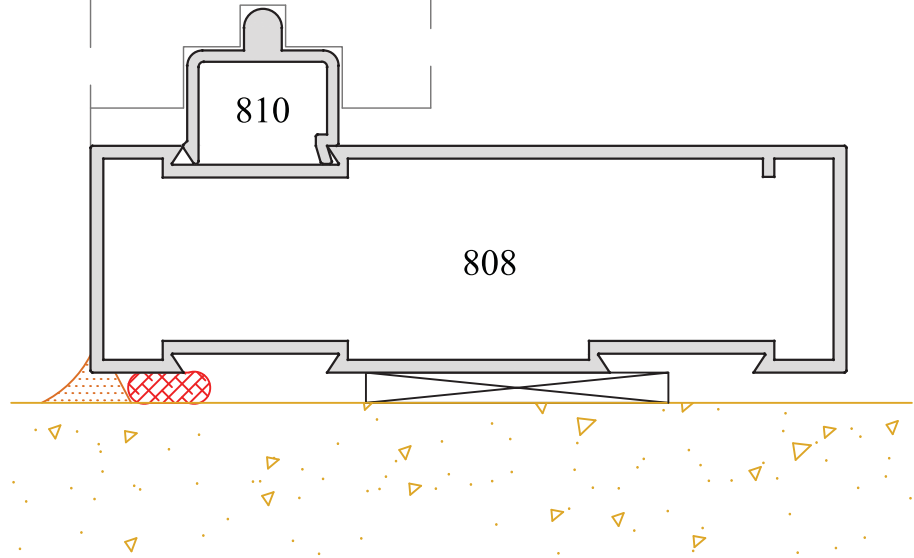



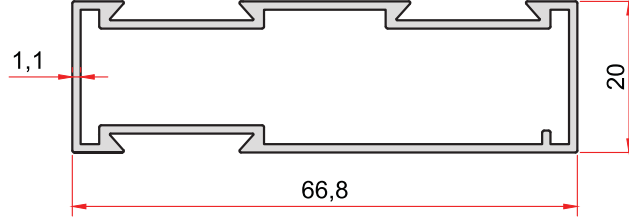

**KOD-CODE** *TEORİK AĞIRLIK*  
*THEORETICAL WEIGHT*  
**885** **0,599 Kg/m**

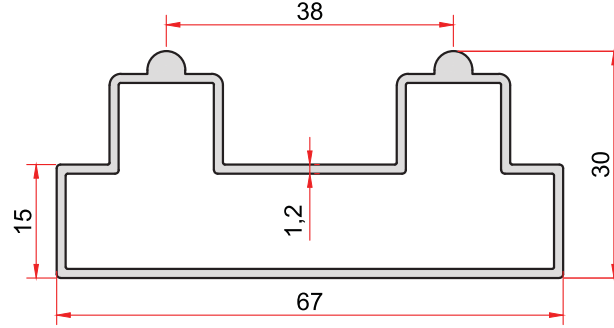

**KOD-CODE** *TEORİK AĞIRLIK*  
*THEORETICAL WEIGHT*  
**898** **0,732 Kg/m**

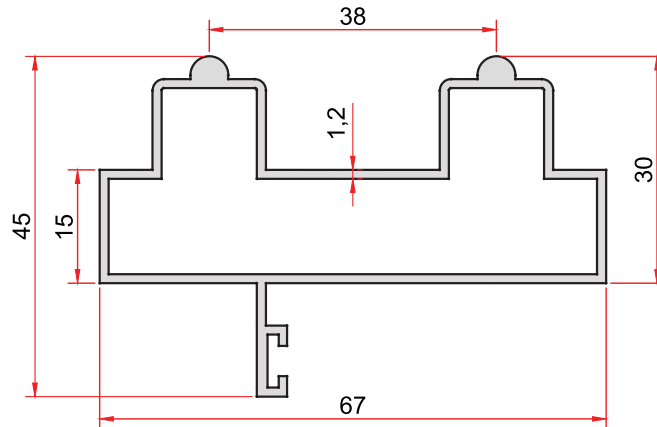

**KOD-CODE** *TEORİK AĞIRLIK*  
*THEORETICAL WEIGHT*  
**816** **0,810 Kg/m**

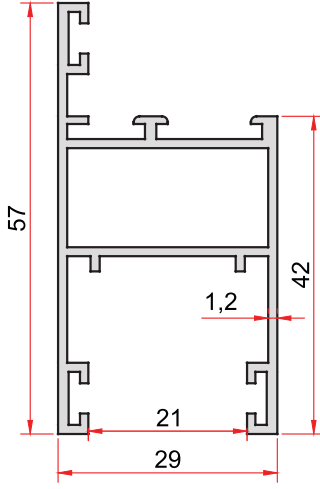

**KOD-CODE** *TEORİK AĞIRLIK*  
**814** *THEORETICAL WEIGHT*  
**0,634 Kg/m**

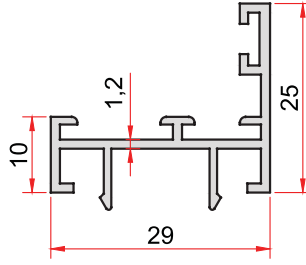

**KOD-CODE** *TEORİK AĞIRLIK*  
**815** *THEORETICAL WEIGHT*  
**0,319 Kg/m**

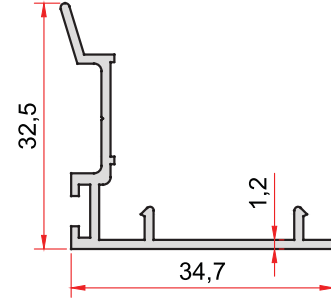

**KOD-CODE** *TEORİK AĞIRLIK*  
**819** *THEORETICAL WEIGHT*  
**0,283 Kg/m**

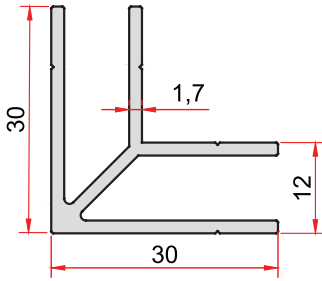

**KOD-CODE** *TEORİK AĞIRLIK*  
**820** *THEORETICAL WEIGHT*  
**0,499 Kg/m**

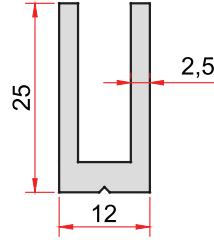

**KOD-CODE** *TEORİK AĞIRLIK*  
**821** *THEORETICAL WEIGHT*  
**0,413 Kg/m**

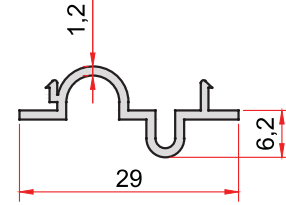

**KOD-CODE** *TEORİK AĞIRLIK*  
**818** *THEORETICAL WEIGHT*  
**0,167 Kg/m**

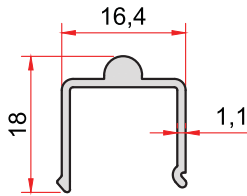

**KOD-CODE** *TEORİK AĞIRLIK*  
**884** *THEORETICAL WEIGHT*  
**0,162 Kg/m**

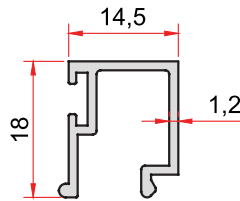

**KOD-CODE** *TEORİK AĞIRLIK*  
**817** *THEORETICAL WEIGHT*  
**0,194 Kg/m**

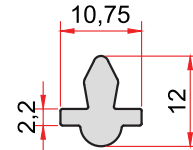

**KOD-CODE** *TEORİK AĞIRLIK*  
**899** *THEORETICAL WEIGHT*  
**0,160 Kg/m**

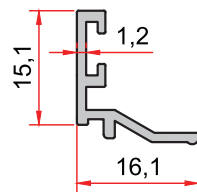

**KOD-CODE** *TEORİK AĞIRLIK*  
**879** *THEORETICAL WEIGHT*  
**0,140 Kg/m**

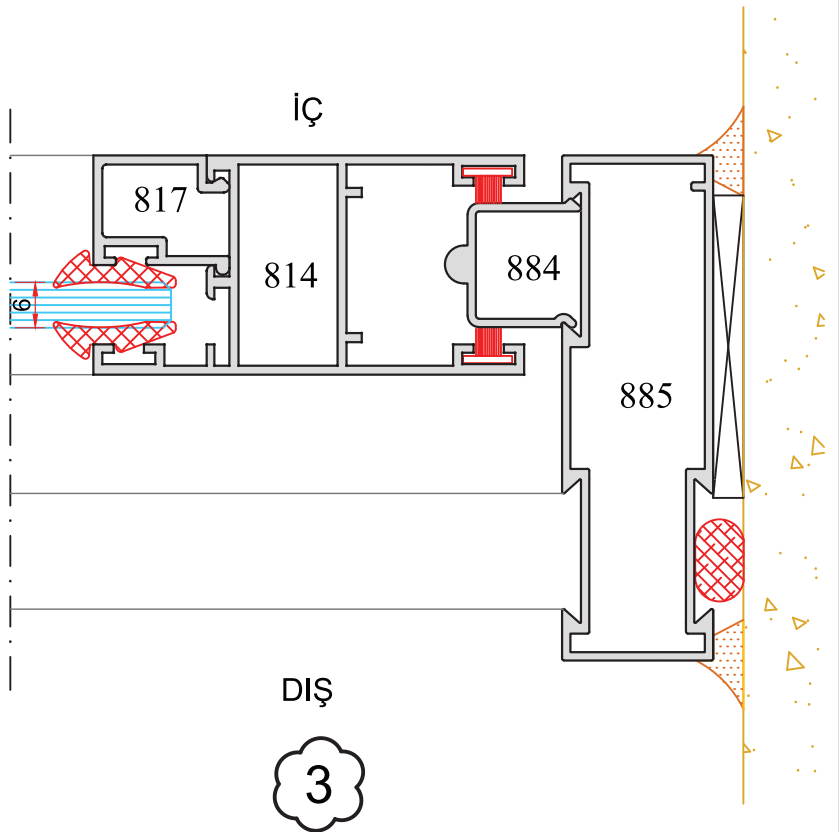
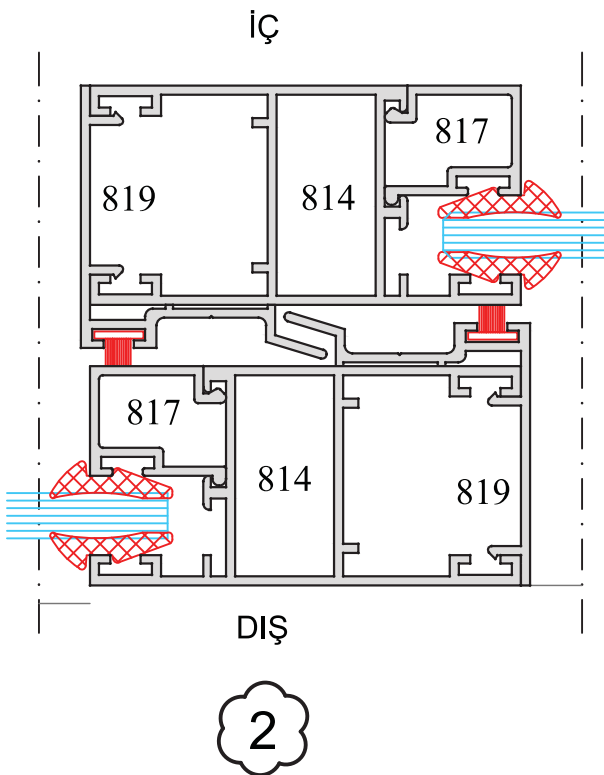
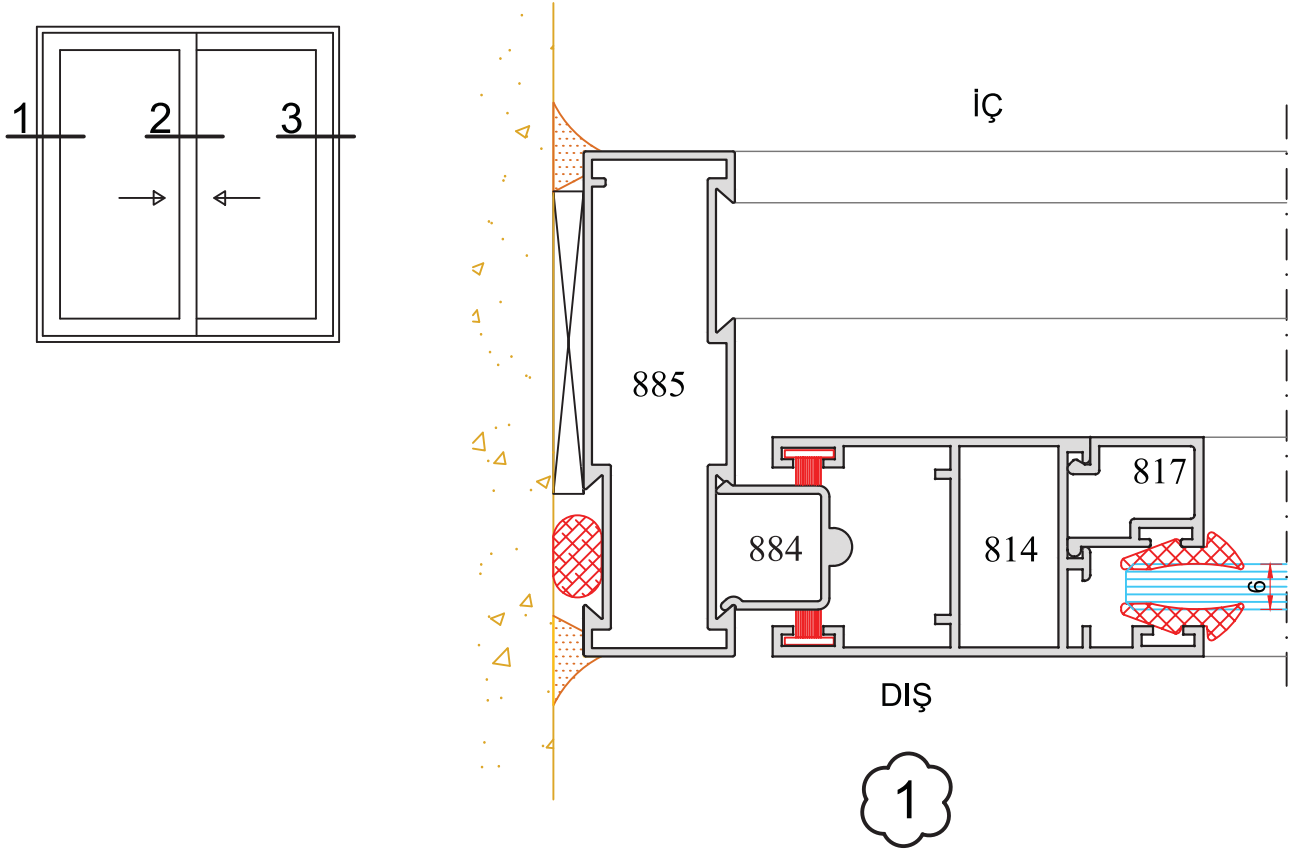

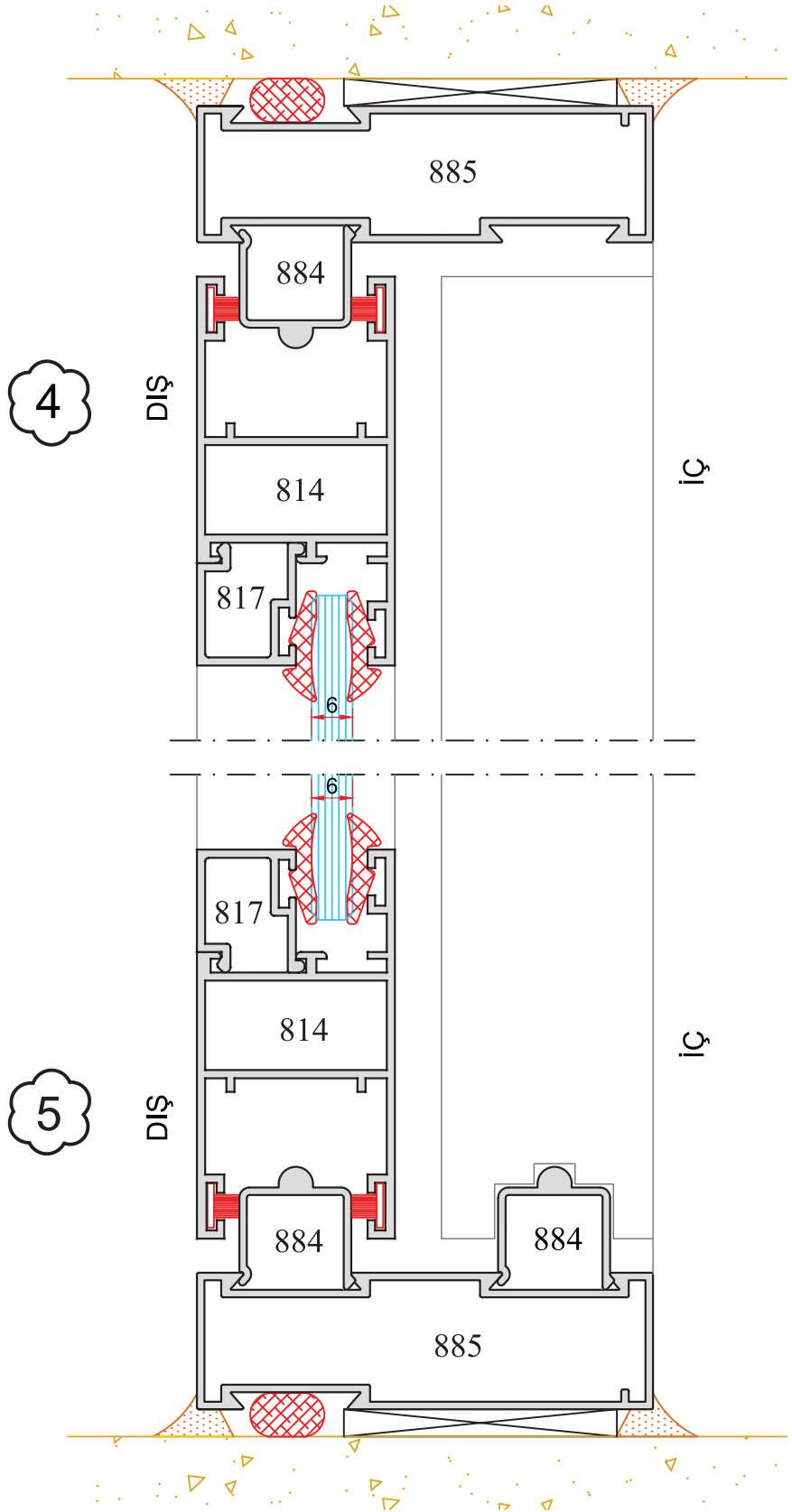
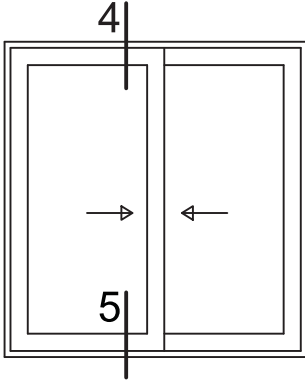

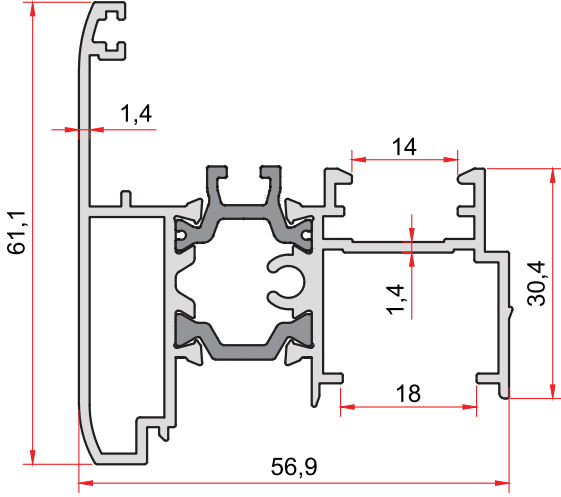

**KOD-CODE** TEORİK AĞIRLIK  
**İD-701-14** THEORETICAL WEIGHT  
**1,213 Kg/m**

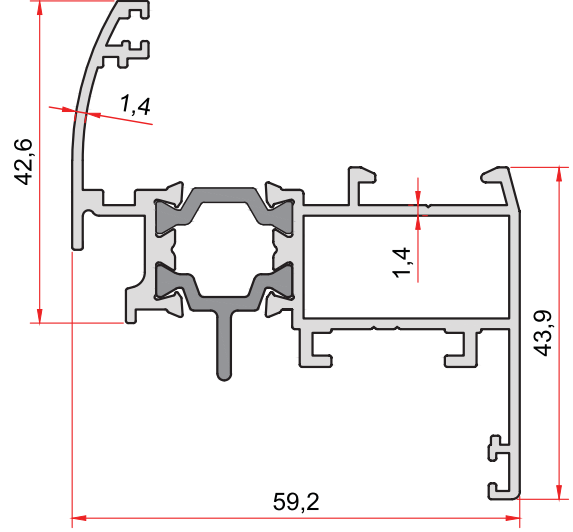

**KOD-CODE** TEORİK AĞIRLIK  
**İD-401-14** THEORETICAL WEIGHT  
**1,197 Kg/m**

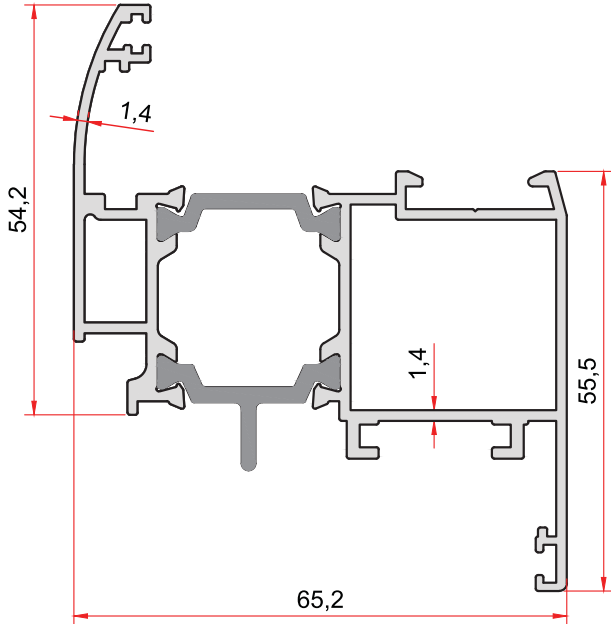

**KOD-CODE** TEORİK AĞIRLIK  
**İD-402-14** THEORETICAL WEIGHT  
**1,457 Kg/m**

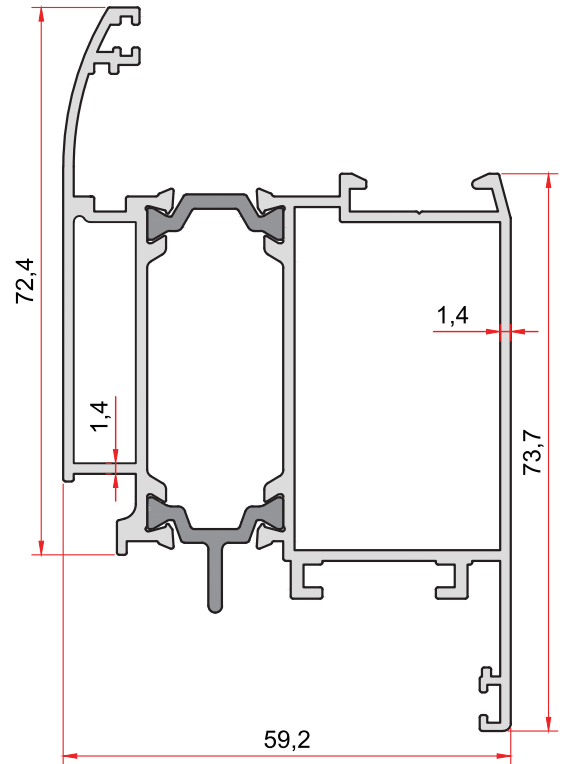

**KOD-CODE** TEORİK AĞIRLIK  
**İD-501-15** THEORETICAL WEIGHT  
**1,702 Kg/m**

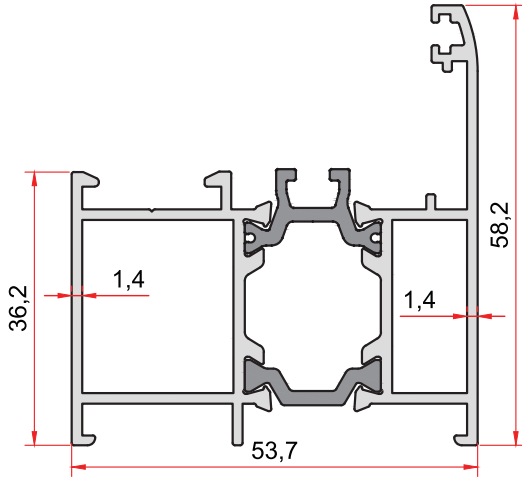

**KOD-CODE** TEORİK AĞIRLIK  
**İD-101-14** THEORETICAL WEIGHT  
**1,214 Kg/m**

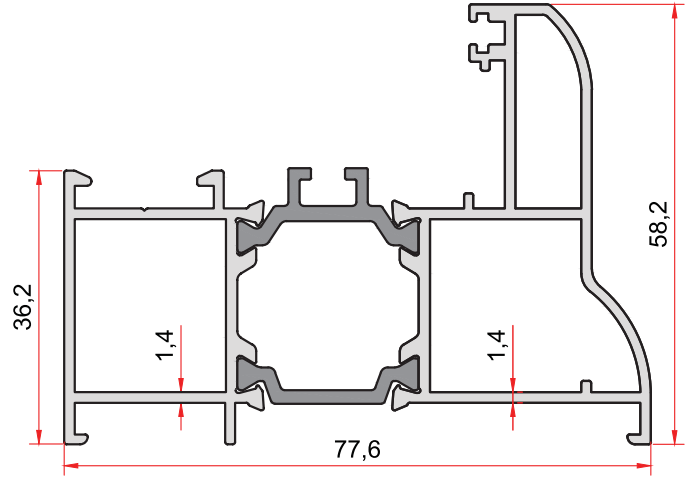

**KOD-CODE** TEORİK AĞIRLIK  
**İD-102-14** THEORETICAL WEIGHT  
**1,506 Kg/m**

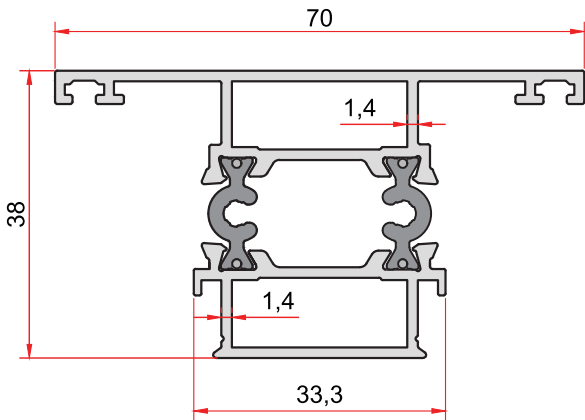

**KOD-CODE** TEORİK AĞIRLIK  
**İD-301-14** THEORETICAL WEIGHT  
**1,086 Kg/m**

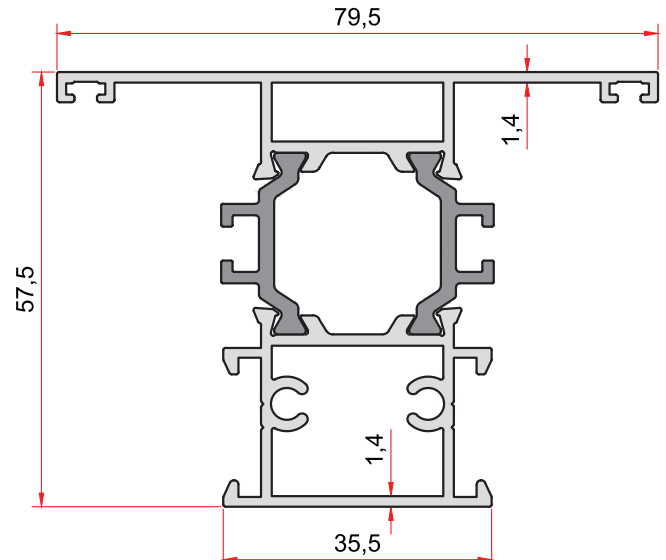

**KOD-CODE** TEORİK AĞIRLIK  
**İD-201-14** THEORETICAL WEIGHT  
**1,429 Kg/m**

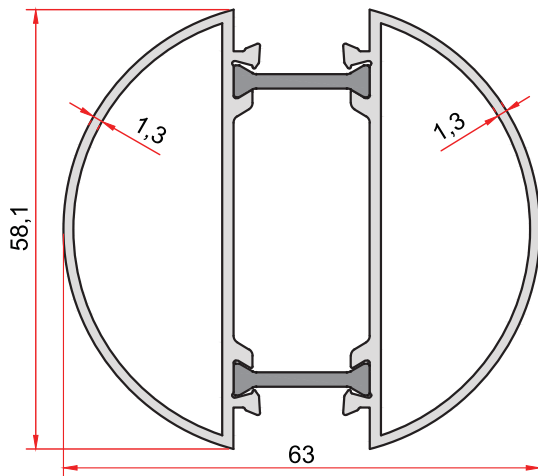

**KOD-CODE** TEORİK AĞIRLIK  
**İD-901-13** THEORETICAL WEIGHT  
**1,251 Kg/m**

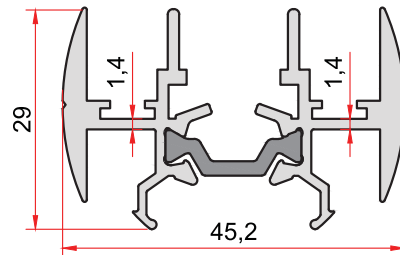

**KOD-CODE** TEORİK AĞIRLIK  
**İD-501-14** THEORETICAL WEIGHT  
**0,857 Kg/m**

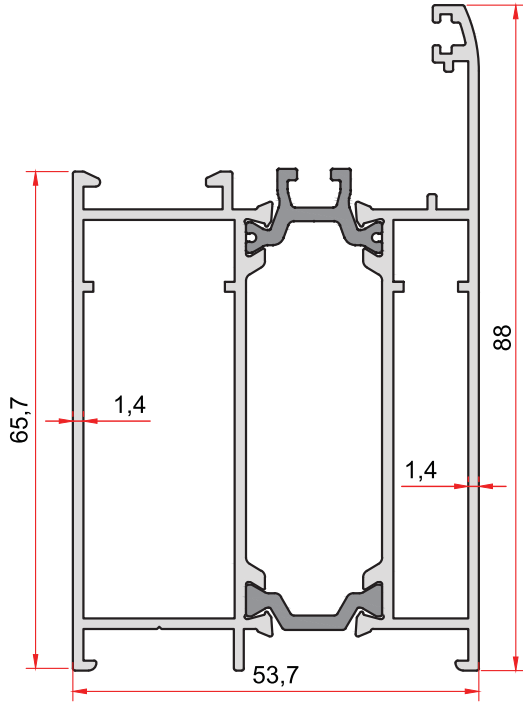

**KOD-CODE** TEORİK AĞIRLIK  
**İD-103-14** THEORETICAL WEIGHT  
**1,699 Kg/m**

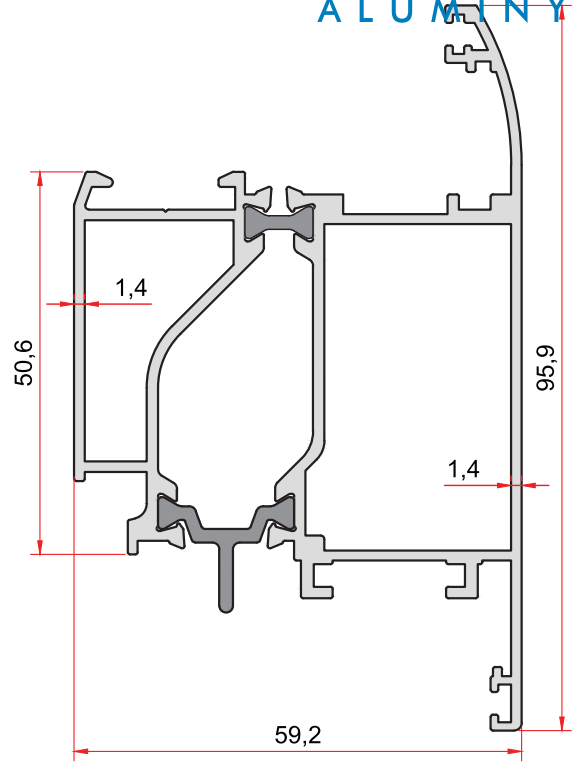

**KOD-CODE** TEORİK AĞIRLIK  
**İD-601-15** THEORETICAL WEIGHT  
**1,763 Kg/m**

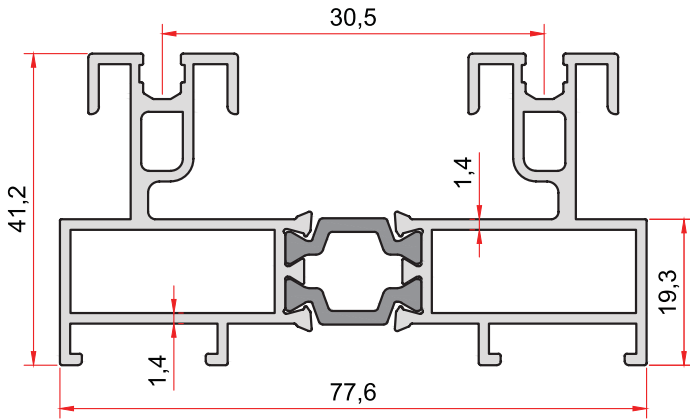

**KOD-CODE** TEORİK AĞIRLIK  
**İS-101-14** THEORETICAL WEIGHT  
**1,572 Kg/m**

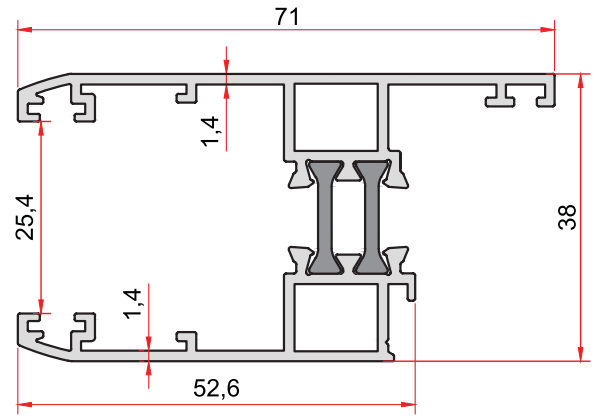

**KOD-CODE** TEORİK AĞIRLIK  
**İS-201-14** THEORETICAL WEIGHT  
**1,068 Kg/m**

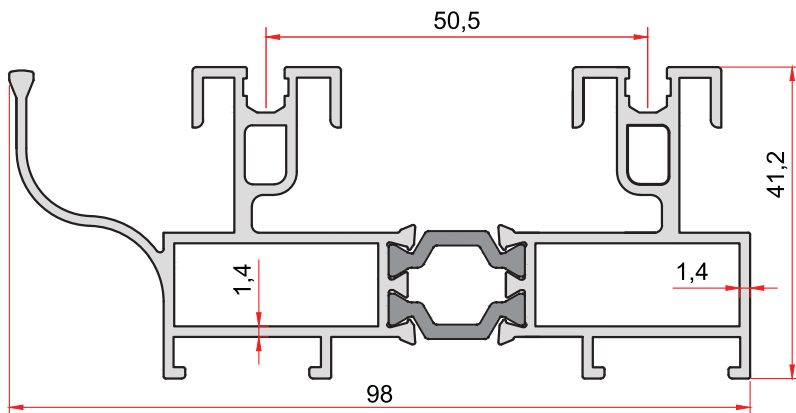

**KOD-CODE** TEORİK AĞIRLIK  
**İS-301-14** THEORETICAL WEIGHT  
**1,713 Kg/m**

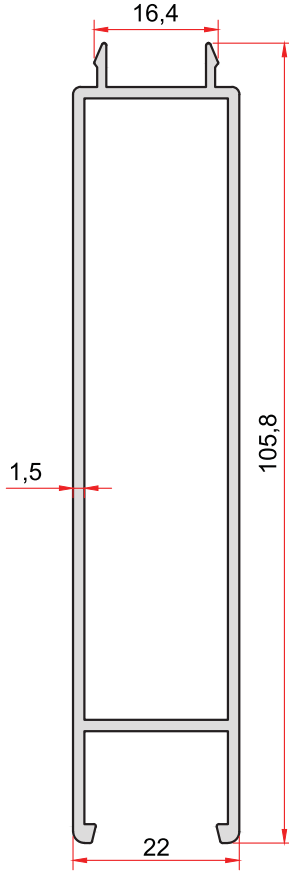

**KOD-CODE** TEORİK AĞIRLIK  
**İD-1011-15** THEORETICAL WEIGHT  
**0,012 Kg/m**

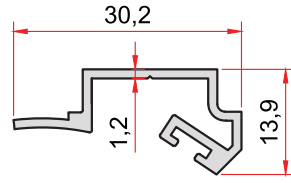

**KOD-CODE** TEORİK AĞIRLIK  
**İS-303-12** THEORETICAL WEIGHT  
**0,216 Kg/m**

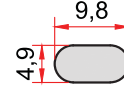

**KOD-CODE** TEORİK AĞIRLIK  
**İS-601-00** THEORETICAL WEIGHT  
**0,113 Kg/m**

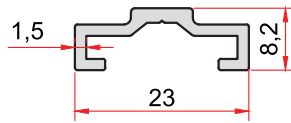

**KOD-CODE** TEORİK AĞIRLIK  
**İS-701-00** THEORETICAL WEIGHT  
**0,167 Kg/m**

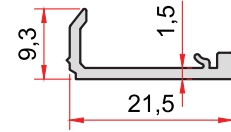

**KOD-CODE** TEORİK AĞIRLIK  
**İS-302-15** THEORETICAL WEIGHT  
**0,130 Kg/m**

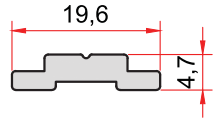

**KOD-CODE** TEORİK AĞIRLIK  
**İS-702-00** THEORETICAL WEIGHT  
**0,170 Kg/m**

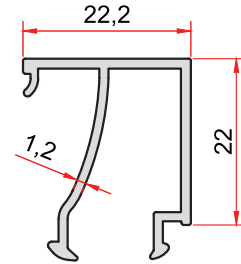

**KOD-CODE** TEORİK AĞIRLIK  
**İS-302-15** THEORETICAL WEIGHT  
**0,286 Kg/m**

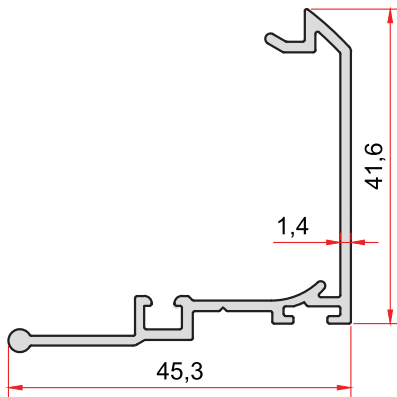

**KOD-CODE** TEORİK AĞIRLIK  
**İS-401-14** THEORETICAL WEIGHT  
**0,423 Kg/m**

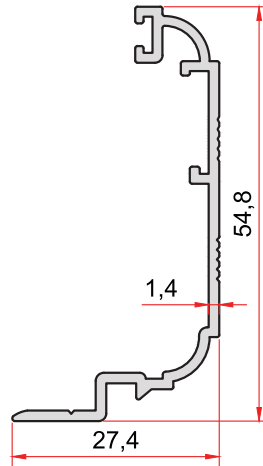

**KOD-CODE** TEORİK AĞIRLIK  
**İS-402-14** THEORETICAL WEIGHT  
**0,375 Kg/m**

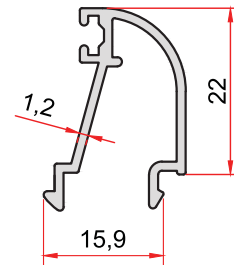

**KOD-CODE** TEORİK AĞIRLIK  
**İS-804-12** THEORETICAL WEIGHT  
**0,243 Kg/m**

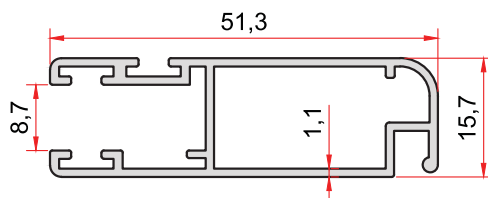

**KOD-CODE** TEORİK AĞIRLIK  
**İD-1012-11** THEORETICAL WEIGHT  
**0,478 Kg/m**



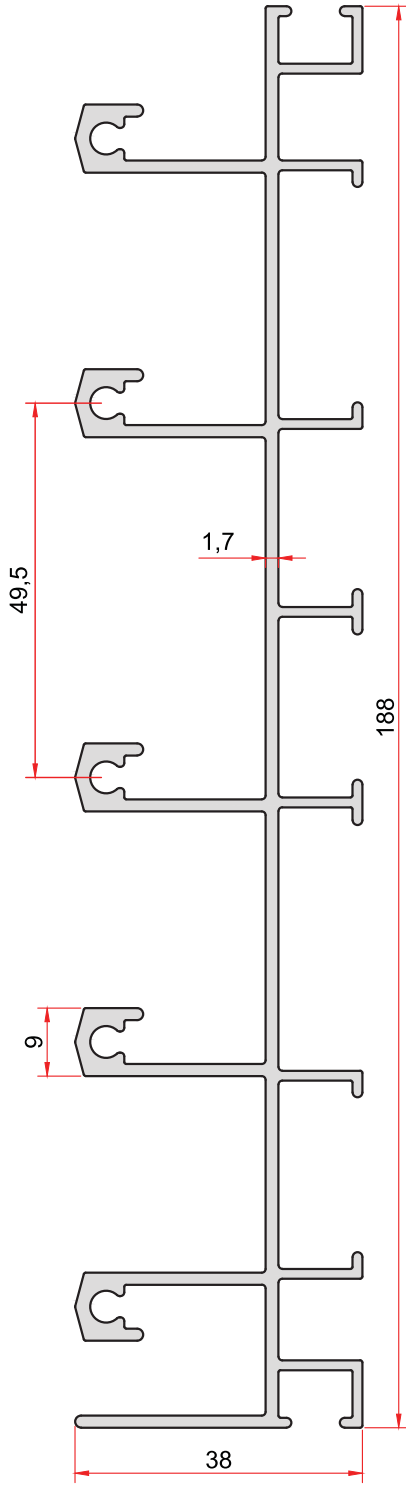

**KOD-CODE** TEORİK AĞIRLIK  
THEORETICAL WEIGHT  
**1000** **2,387 Kg/m**

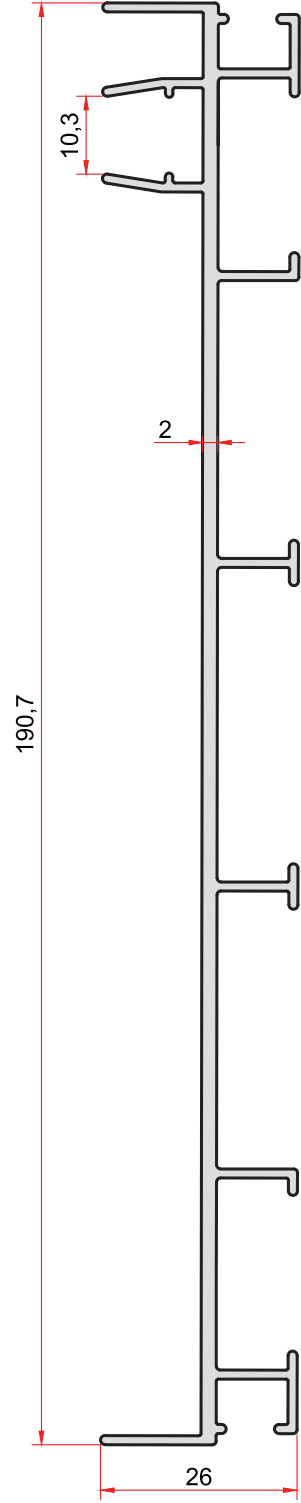

**KOD-CODE** TEORİK AĞIRLIK  
THEORETICAL WEIGHT  
**1006** **1,540 Kg/m**

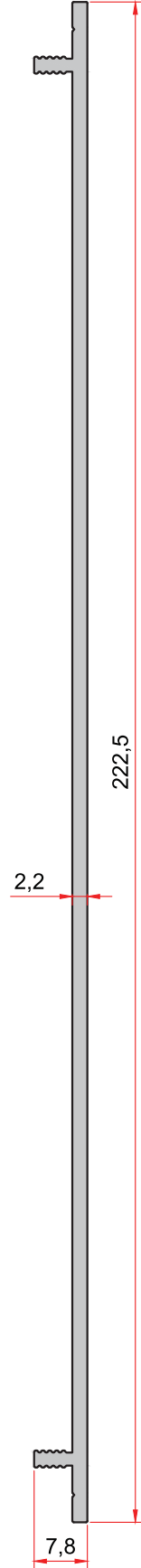

TEORİK AĞIRLIK  
THEORETICAL WEIGHT  
**KOD-CODE**  
**1094** **1,388 Kg/m**

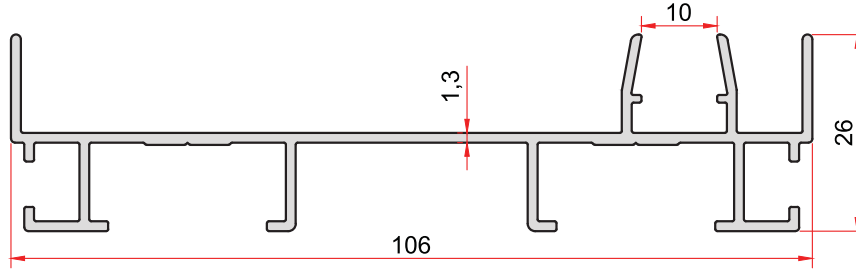

**KOD-CODE** *TEORİK AĞIRLIK*  
*THEORETICAL WEIGHT*  
**1024** **0,859 Kg/m**

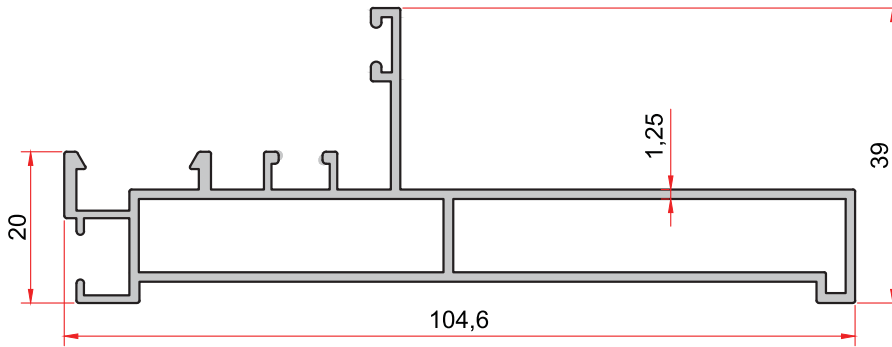

**KOD-CODE** *TEORİK AĞIRLIK*  
*THEORETICAL WEIGHT*  
**1076** **1,032 Kg/m**

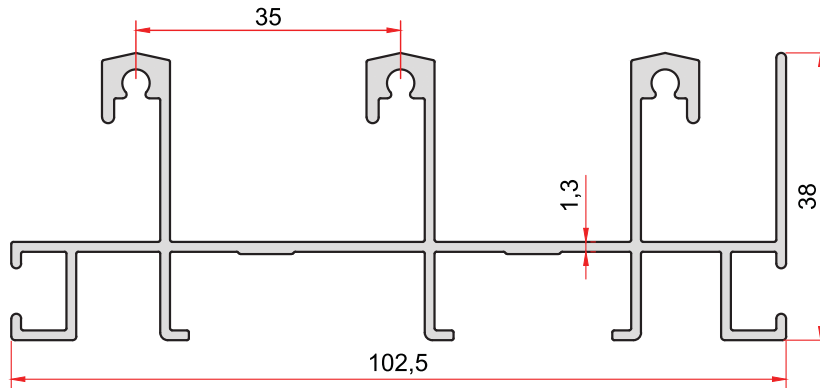

**KOD-CODE** *TEORİK AĞIRLIK*  
*THEORETICAL WEIGHT*  
**1007** **1,320 Kg/m**

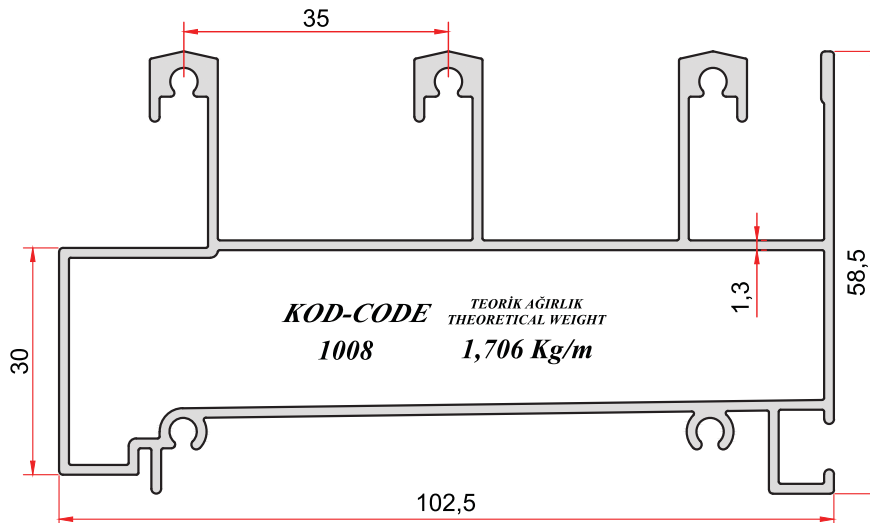

**KOD-CODE** *TEORİK AĞIRLIK*  
*THEORETICAL WEIGHT*  
**1008** **1,706 Kg/m**

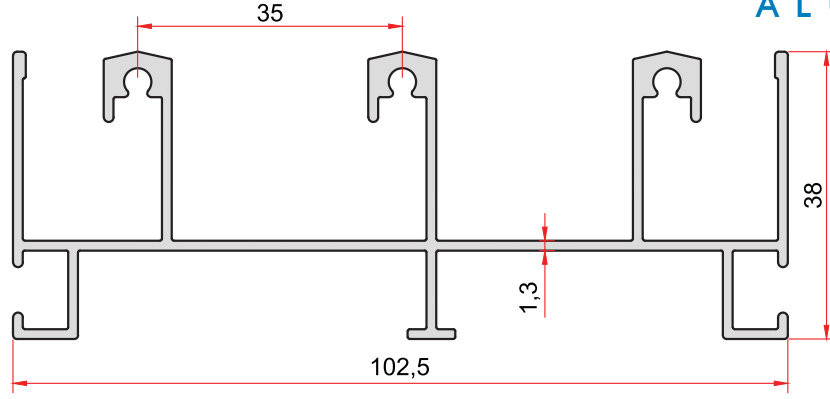

**KOD-CODE** *TEORİK AĞIRLIK*  
*THEORETICAL WEIGHT*  
**1009** **1,307 Kg/m**

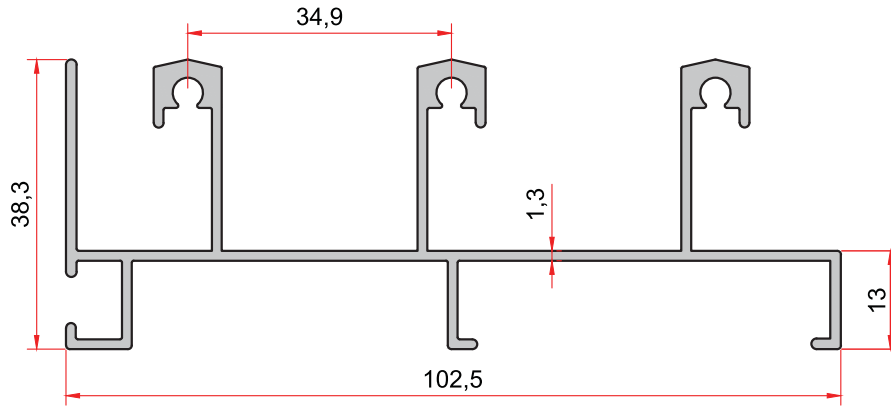

**KOD-CODE** *TEORİK AĞIRLIK*  
*THEORETICAL WEIGHT*  
**1078** **1,190 Kg/m**

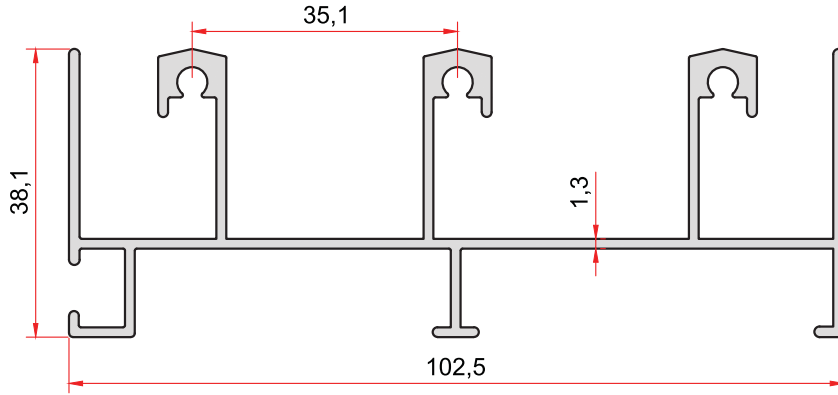

**KOD-CODE** *TEORİK AĞIRLIK*  
*THEORETICAL WEIGHT*  
**1079** **1,288 Kg/m**

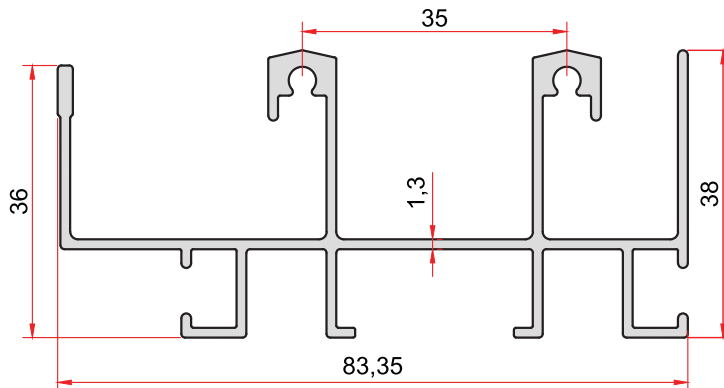

**KOD-CODE** *TEORİK AĞIRLIK*  
*THEORETICAL WEIGHT*  
**1004** **1,099 Kg/m**

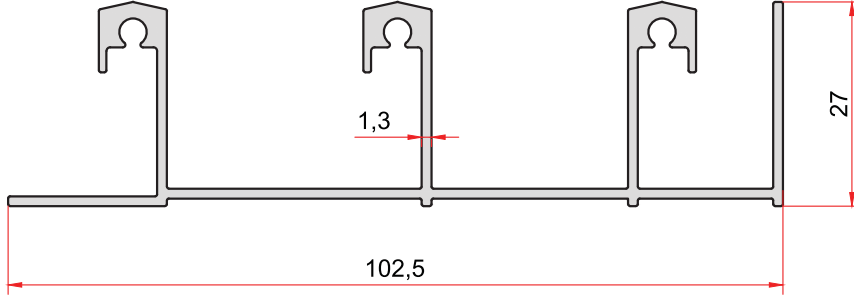

**KOD-CODE**      **TEORİK AĞIRLIK**  
**7032**            **THEORETICAL WEIGHT**  
                         **1,000 Kg/m**

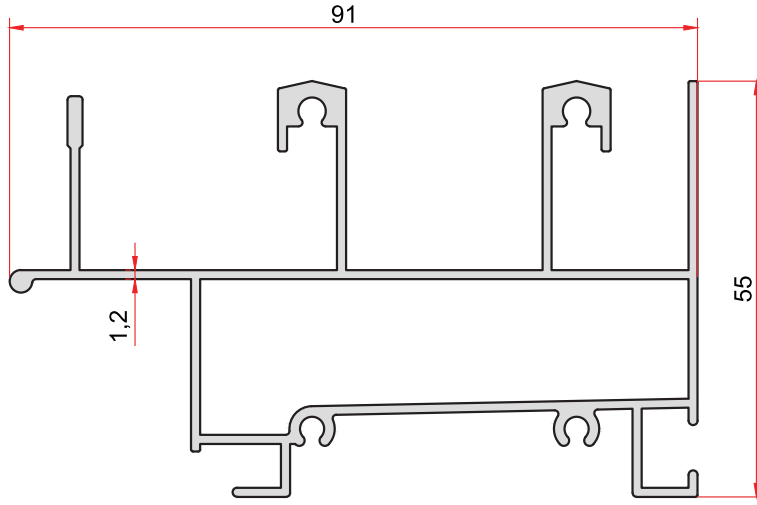

**KOD-CODE**      **TEORİK AĞIRLIK**  
**7004**            **THEORETICAL WEIGHT**  
                         **1,358 Kg/m**

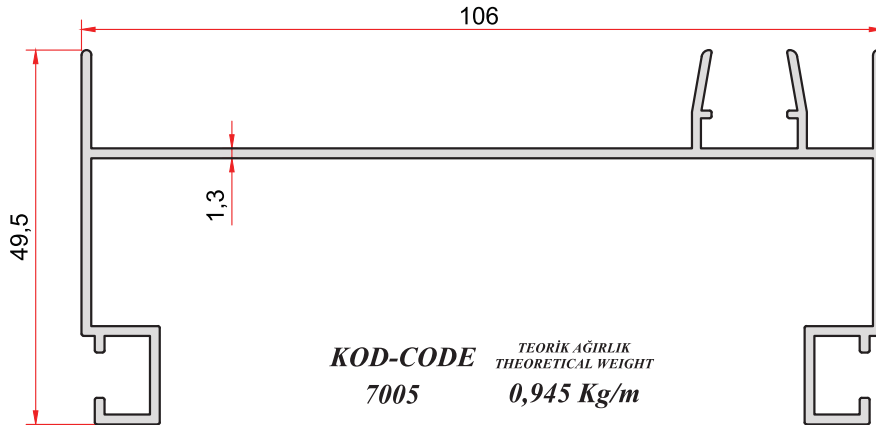

**KOD-CODE**      **TEORİK AĞIRLIK**  
**7005**            **THEORETICAL WEIGHT**  
                         **0,945 Kg/m**

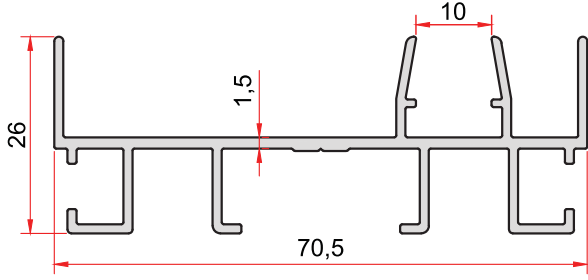

**KOD-CODE** TEORİK AĞIRLIK  
1022 THEORETICAL WEIGHT  
0,705 Kg/m

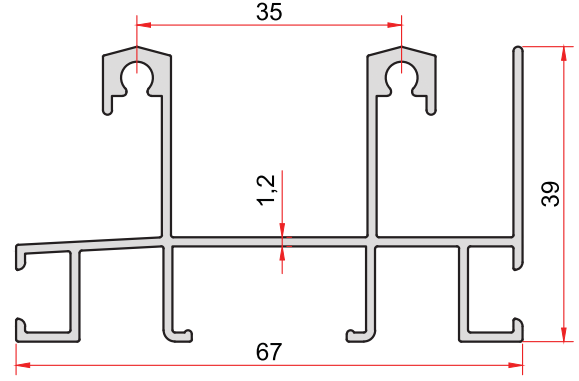

**KOD-CODE** TEORİK AĞIRLIK  
1081 THEORETICAL WEIGHT  
0,888 Kg/m

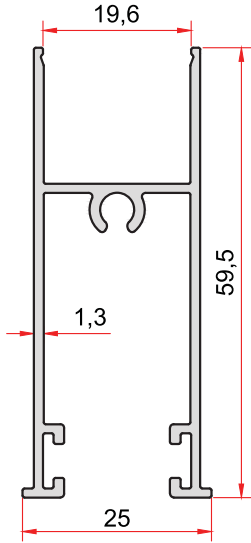

**KOD-CODE** TEORİK AĞIRLIK  
1001 THEORETICAL WEIGHT  
0,583 Kg/m

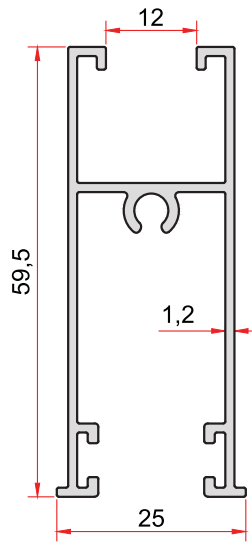

**KOD-CODE** TEORİK AĞIRLIK  
1020 THEORETICAL WEIGHT  
0,599 Kg/m

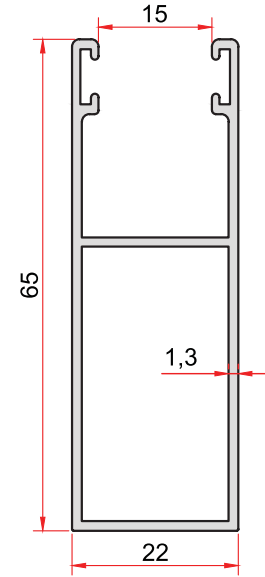

**KOD-CODE** TEORİK AĞIRLIK  
1070 THEORETICAL WEIGHT  
0,623 Kg/m

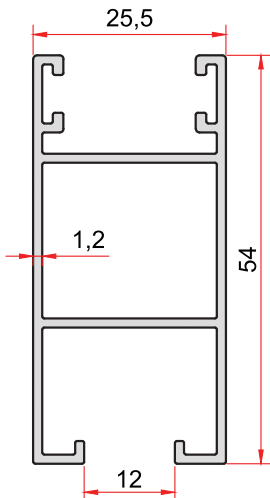

**KOD-CODE** TEORİK AĞIRLIK  
1002 THEORETICAL WEIGHT  
0,605 Kg/m

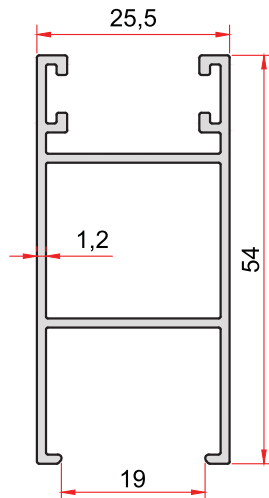

**KOD-CODE** TEORİK AĞIRLIK  
1021 THEORETICAL WEIGHT  
0,569 Kg/m

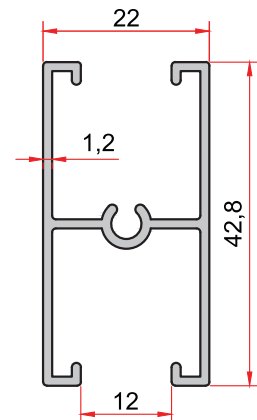

**KOD-CODE** TEORİK AĞIRLIK  
1082 THEORETICAL WEIGHT  
0,437 Kg/m

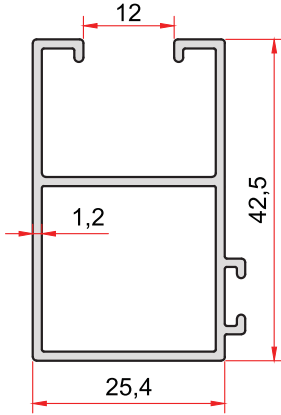

**KOD-CODE** *TEORİK AĞIRLIK*  
**1011** *THEORETICAL WEIGHT*  
**0,495 Kg/m**

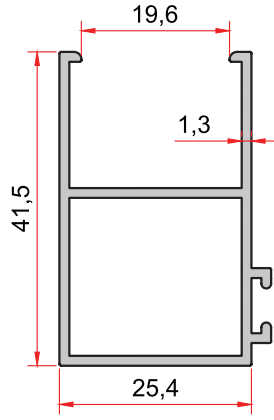

**KOD-CODE** *TEORİK AĞIRLIK*  
**1088** *THEORETICAL WEIGHT*  
**0,489 Kg/m**

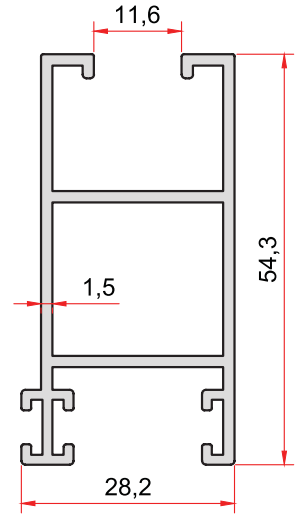

**KOD-CODE** *TEORİK AĞIRLIK*  
**1071** *THEORETICAL WEIGHT*  
**0,762 Kg/m**

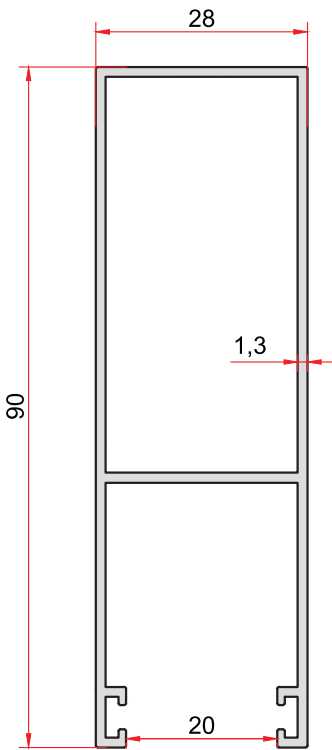

**KOD-CODE** *TEORİK AĞIRLIK*  
**7009** *THEORETICAL WEIGHT*  
**0,861 Kg/m**

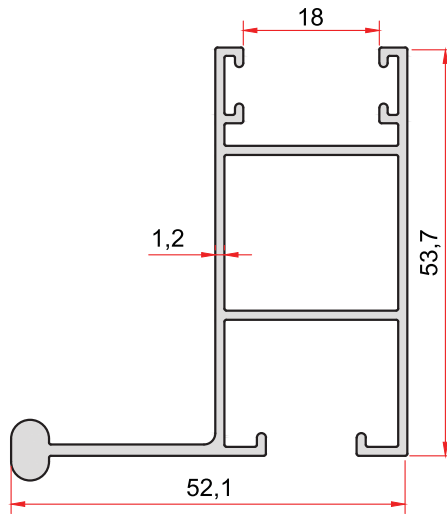

**KOD-CODE** *TEORİK AĞIRLIK*  
**1013** *THEORETICAL WEIGHT*  
**0,775 Kg/m**

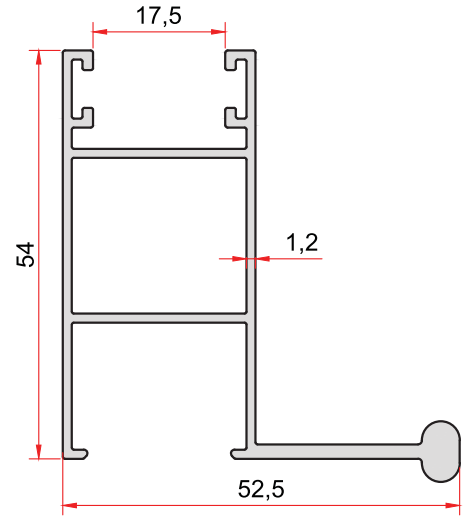

**KOD-CODE** *TEORİK AĞIRLIK*  
**1014** *THEORETICAL WEIGHT*  
**0,776 Kg/m**

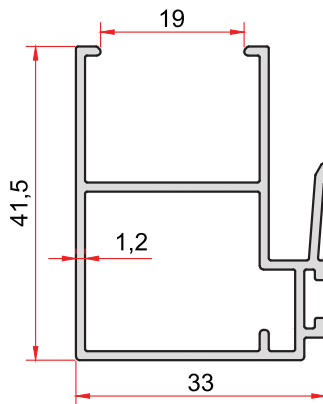

**KOD-CODE** *TEORİK AĞIRLIK*  
**1003** *THEORETICAL WEIGHT*  
**0,540 Kg/m**

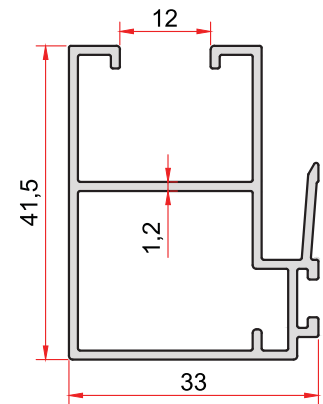

**KOD-CODE** *TEORİK AĞIRLIK*  
**1005** *THEORETICAL WEIGHT*  
**0,575 Kg/m**

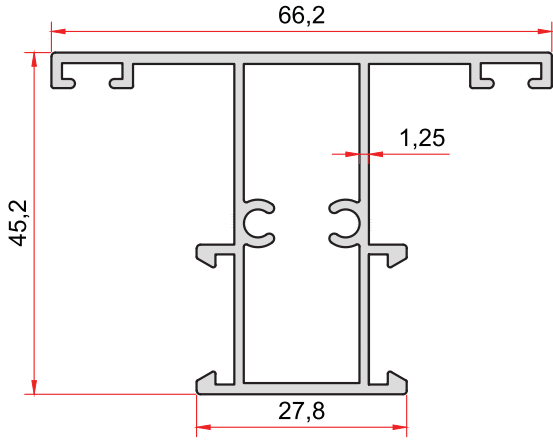

**KOD-CODE** TEORİK AĞIRLIK  
THEORETICAL WEIGHT  
**1073** **0,850 Kg/m**

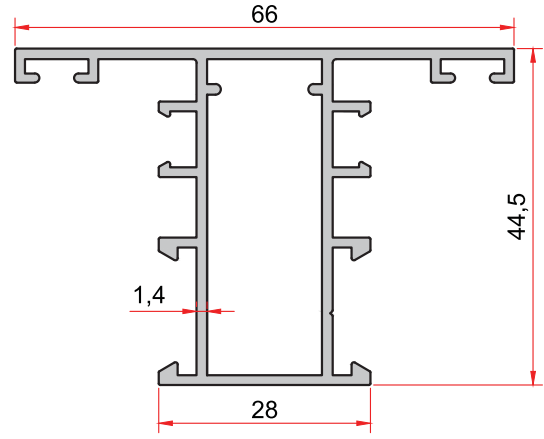

**KOD-CODE** TEORİK AĞIRLIK  
THEORETICAL WEIGHT  
**1084** **0,886 Kg/m**

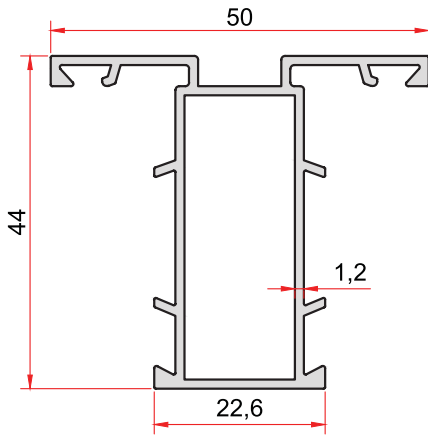

**KOD-CODE** TEORİK AĞIRLIK  
THEORETICAL WEIGHT  
**1083** **0,626 Kg/m**

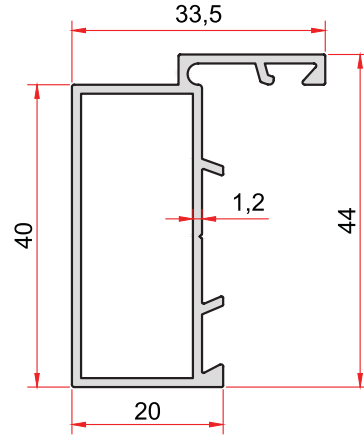

**KOD-CODE** TEORİK AĞIRLIK  
THEORETICAL WEIGHT  
**1074** **0,494 Kg/m**

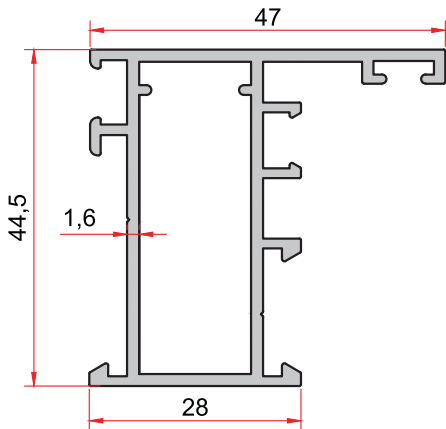

**KOD-CODE** TEORİK AĞIRLIK  
THEORETICAL WEIGHT  
**1089** **0,826 Kg/m**

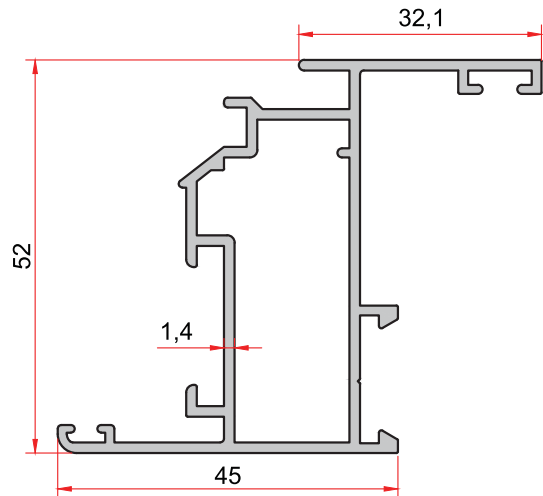

**KOD-CODE** TEORİK AĞIRLIK  
THEORETICAL WEIGHT  
**1085** **0,875 Kg/m**

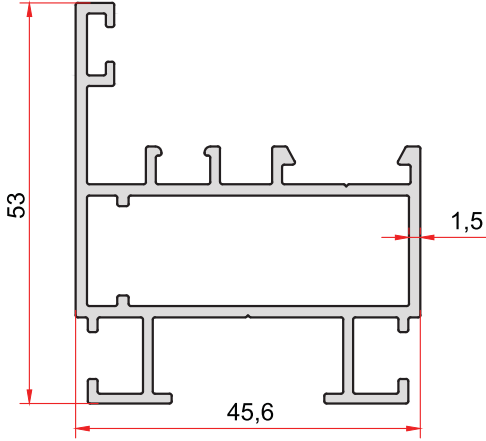

**KOD-CODE** *TEORİK AĞIRLIK*  
*THEORETICAL WEIGHT*  
**7033** **0,899 Kg/m**

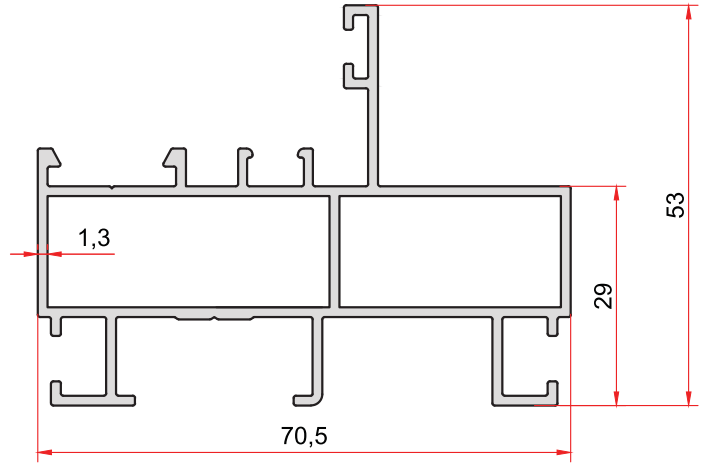

**KOD-CODE** *TEORİK AĞIRLIK*  
*THEORETICAL WEIGHT*  
**7034** **1,085 Kg/m**

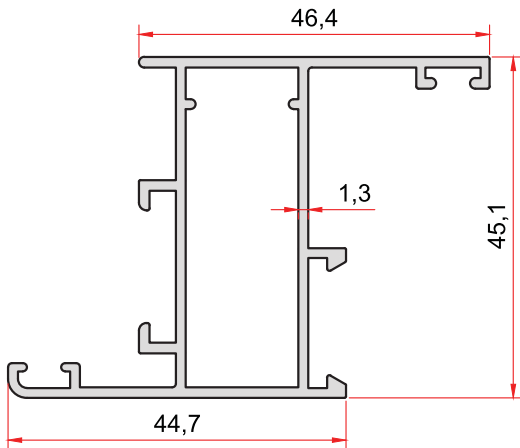

**KOD-CODE** *TEORİK AĞIRLIK*  
*THEORETICAL WEIGHT*  
**1077** **0,788 Kg/m**

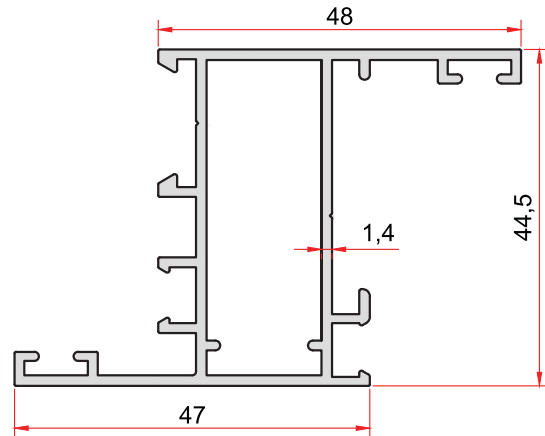

**KOD-CODE** *TEORİK AĞIRLIK*  
*THEORETICAL WEIGHT*  
**1086** **0,859 Kg/m**

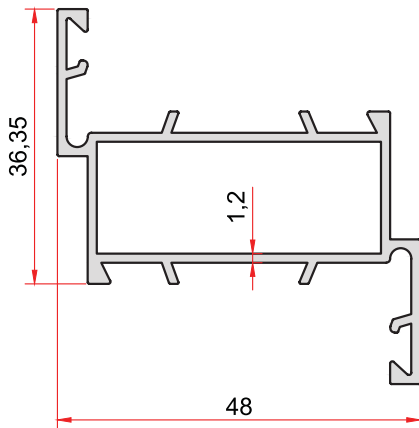

**KOD-CODE** *TEORİK AĞIRLIK*  
*THEORETICAL WEIGHT*  
**1012** **0,632 Kg/m**

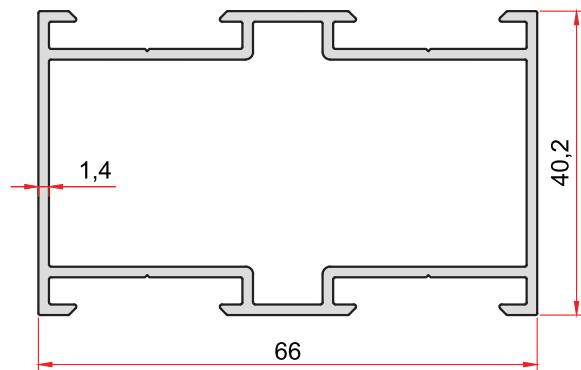

**KOD-CODE** *TEORİK AĞIRLIK*  
*THEORETICAL WEIGHT*  
**1036** **0,944 Kg/m**



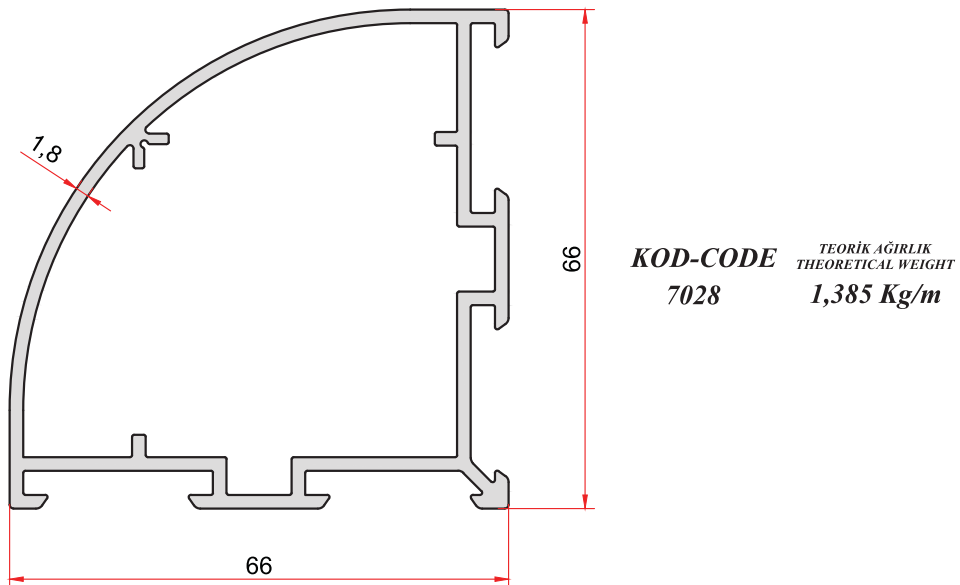
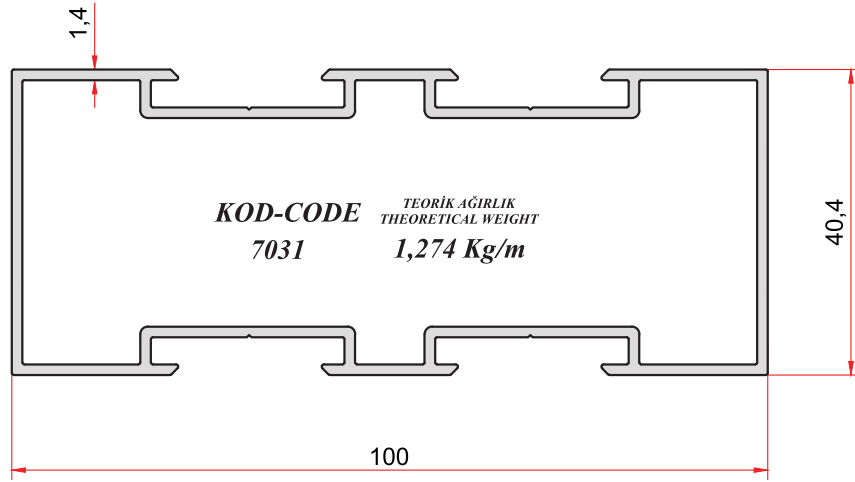
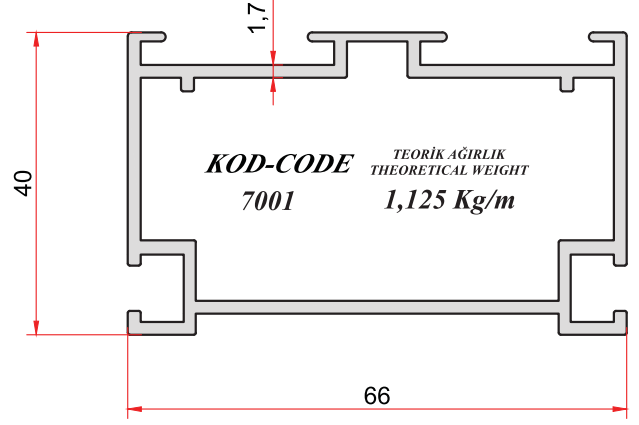
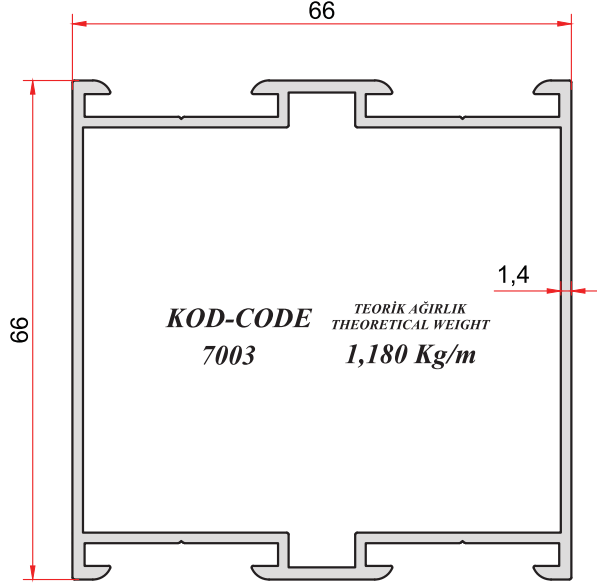

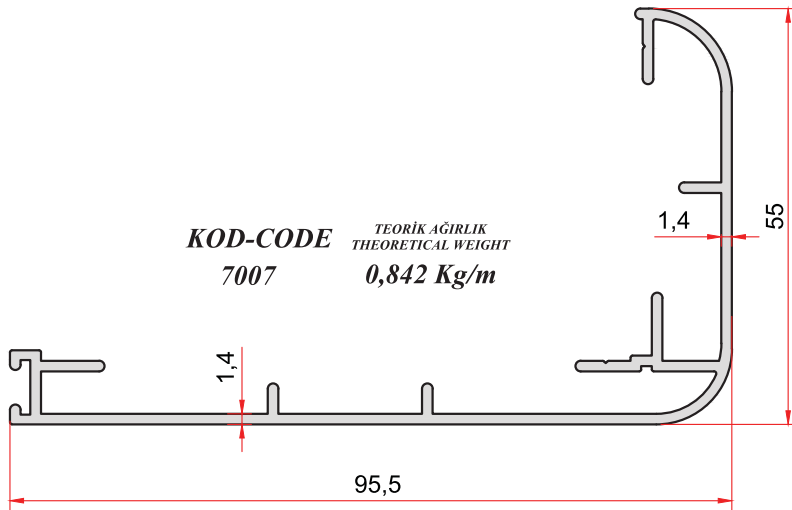
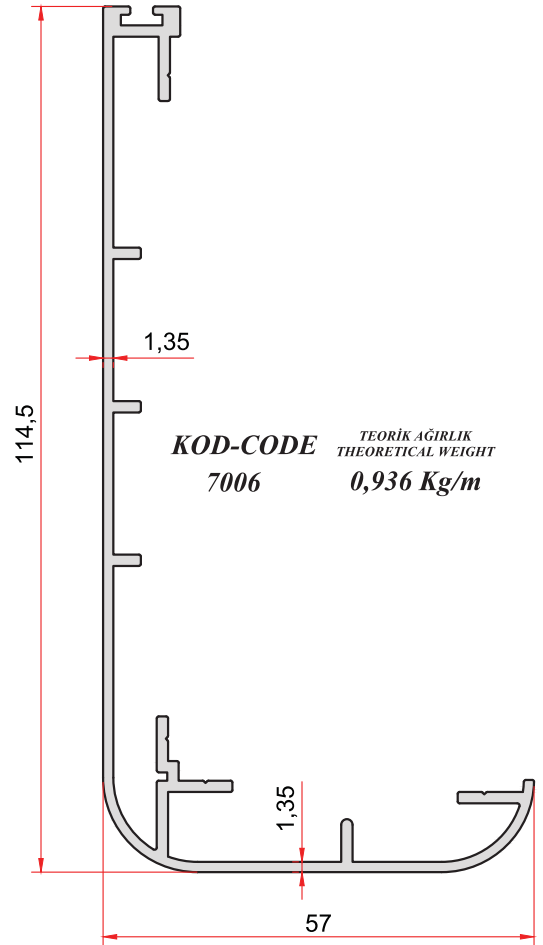
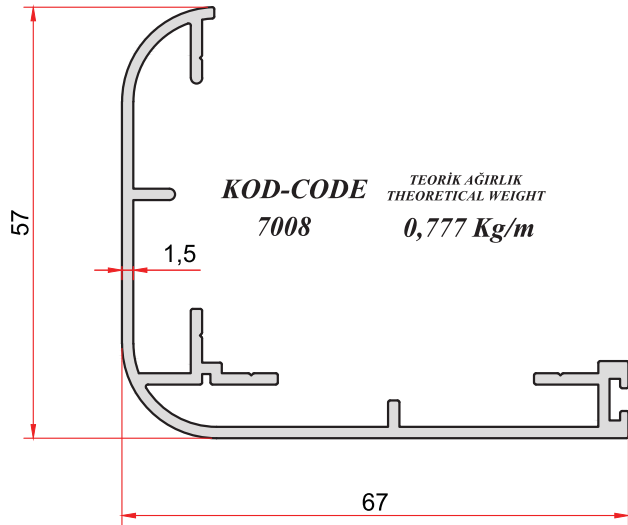
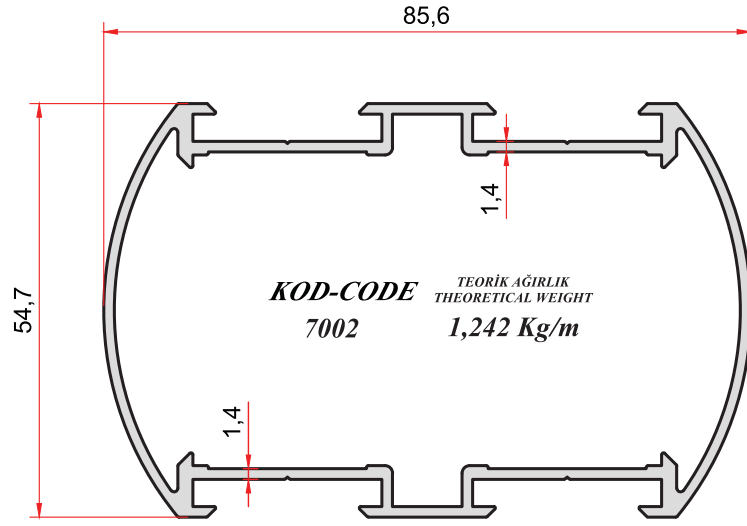

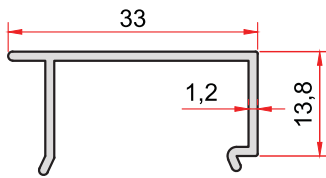
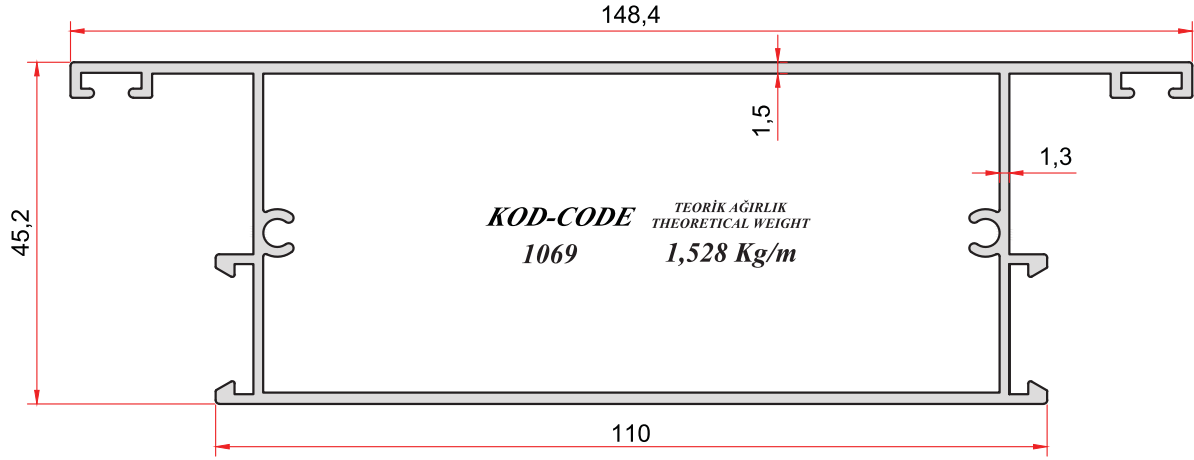

**KOD-CODE**      **TEORİK AĞIRLIK**  
**1023**            **THEORETICAL WEIGHT**  
                         **0,211 Kg/m**

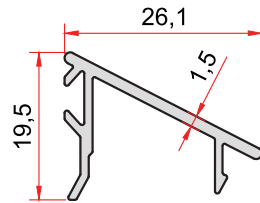

**KOD-CODE**      **TEORİK AĞIRLIK**  
**1033**            **THEORETICAL WEIGHT**  
                         **0,208 Kg/m**

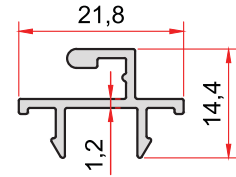

**KOD-CODE**      **TEORİK AĞIRLIK**  
**1037**            **THEORETICAL WEIGHT**  
                         **0,178 Kg/m**

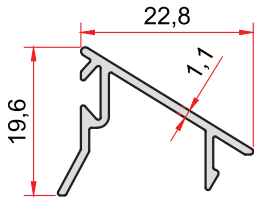

**KOD-CODE**      **TEORİK AĞIRLIK**  
**1039**            **THEORETICAL WEIGHT**  
                         **0,173 Kg/m**

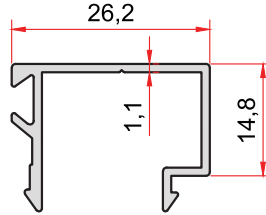

**KOD-CODE**      **TEORİK AĞIRLIK**  
**1087**            **THEORETICAL WEIGHT**  
                         **0,233 Kg/m**

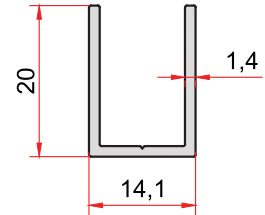

**KOD-CODE**      **TEORİK AĞIRLIK**  
**7035**            **THEORETICAL WEIGHT**  
                         **0,194 Kg/m**

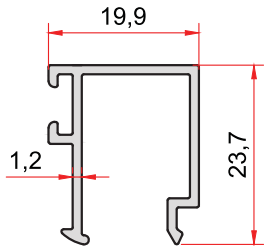

**KOD-CODE**      **TEORİK AĞIRLIK**  
**7029**            **THEORETICAL WEIGHT**  
                         **0,246 Kg/m**

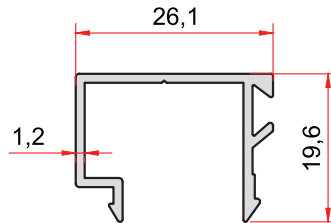

**KOD-CODE**      **TEORİK AĞIRLIK**  
**7030**            **THEORETICAL WEIGHT**  
                         **0,240 Kg/m**

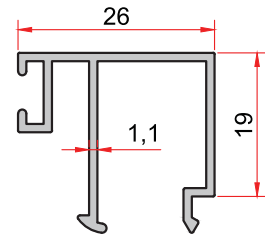

**KOD-CODE**      **TEORİK AĞIRLIK**  
**1096**            **THEORETICAL WEIGHT**  
                         **0,278 Kg/m**

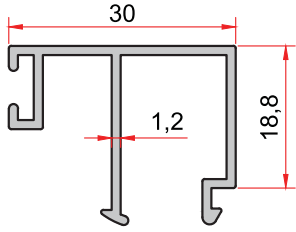

**KOD-CODE** 1095  
**TEORİK AĞIRLIK**  
**THEORETICAL WEIGHT** 0,318 Kg/m

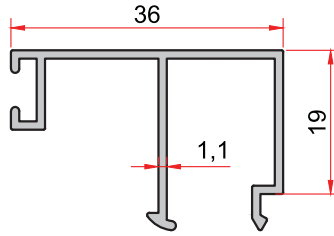

**KOD-CODE** 1097  
**TEORİK AĞIRLIK**  
**THEORETICAL WEIGHT** 0,308 Kg/m

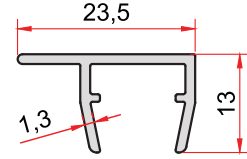

**KOD-CODE** 1028  
**TEORİK AĞIRLIK**  
**THEORETICAL WEIGHT** 0,171 Kg/m

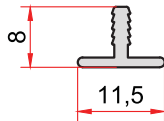

**KOD-CODE** 7012  
**TEORİK AĞIRLIK**  
**THEORETICAL WEIGHT** 0,076 Kg/m

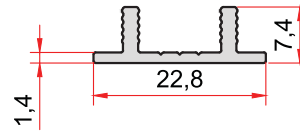

**KOD-CODE** 1025  
**TEORİK AĞIRLIK**  
**THEORETICAL WEIGHT** 0,153 Kg/m

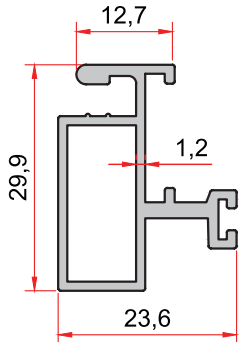

**KOD-CODE** 1072  
**TEORİK AĞIRLIK**  
**THEORETICAL WEIGHT** 0,397 Kg/m

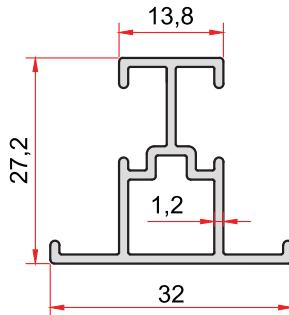

**KOD-CODE** 1029  
**TEORİK AĞIRLIK**  
**THEORETICAL WEIGHT** 0,348 Kg/m

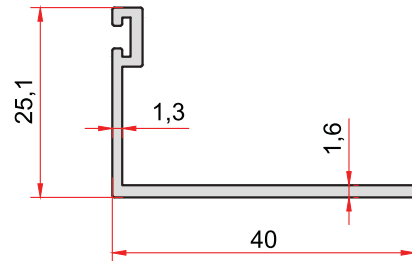

**KOD-CODE** 7011  
**TEORİK AĞIRLIK**  
**THEORETICAL WEIGHT** 0,286 Kg/m

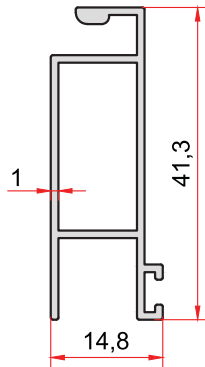

**KOD-CODE** 7010  
**TEORİK AĞIRLIK**  
**THEORETICAL WEIGHT** 0,313 Kg/m

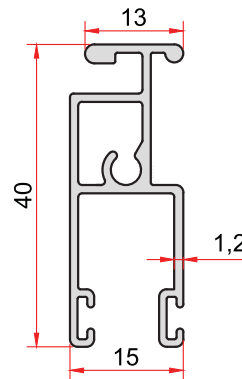

**KOD-CODE** 1026  
**TEORİK AĞIRLIK**  
**THEORETICAL WEIGHT** 0,394 Kg/m

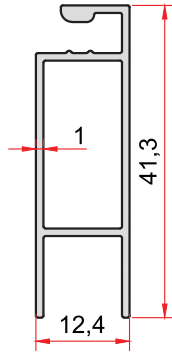

**KOD-CODE** *TEORİK AĞIRLIK*  
*THEORETICAL WEIGHT*  
**1027** **0,297 Kg/m**

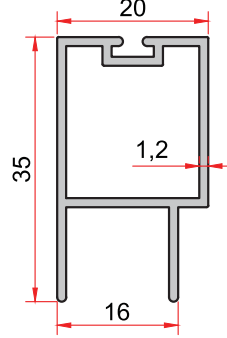

**KOD-CODE** *TEORİK AĞIRLIK*  
*THEORETICAL WEIGHT*  
**1092** **0,365 Kg/m**

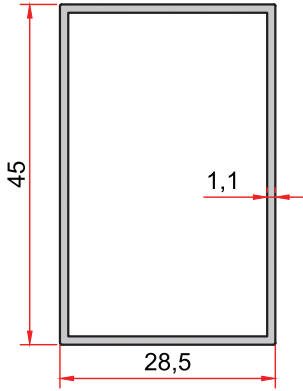

**KOD-CODE** *TEORİK AĞIRLIK*  
*THEORETICAL WEIGHT*  
**1091** **0,424 Kg/m**

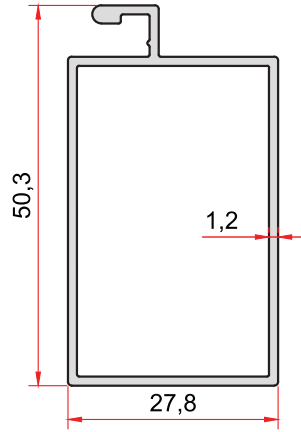

**KOD-CODE** *TEORİK AĞIRLIK*  
*THEORETICAL WEIGHT*  
**1010** **0,504 Kg/m**

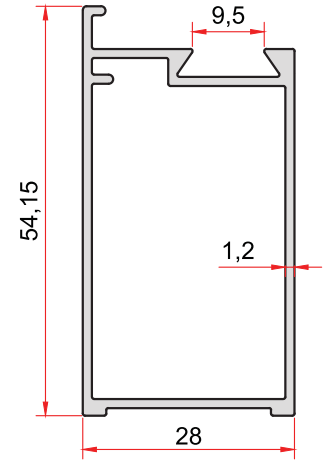

**KOD-CODE** *TEORİK AĞIRLIK*  
*THEORETICAL WEIGHT*  
**1032** **0,575 Kg/m**

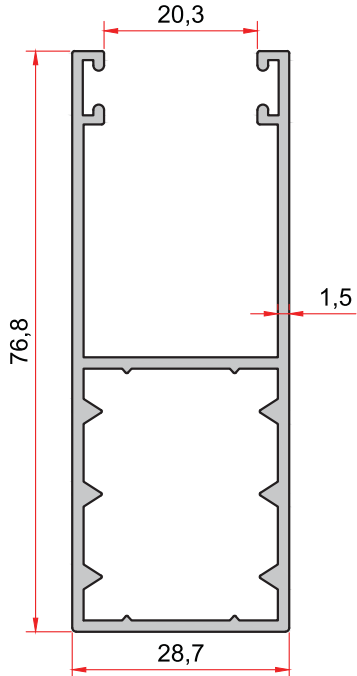

**KOD-CODE** *TEORİK AĞIRLIK*  
*THEORETICAL WEIGHT*  
**1075** **0,953 Kg/m**

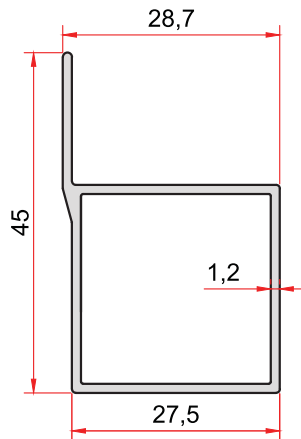

**KOD-CODE** *TEORİK AĞIRLIK*  
*THEORETICAL WEIGHT*  
**1017** **0,406 Kg/m**

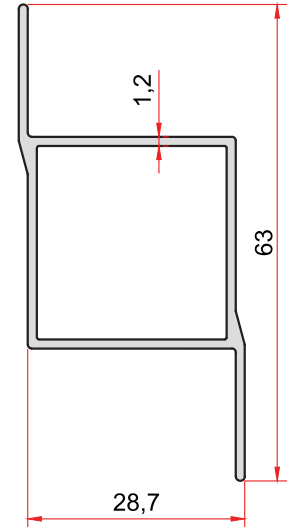

**KOD-CODE** *TEORİK AĞIRLIK*  
*THEORETICAL WEIGHT*  
**1018** **0,475 Kg/m**

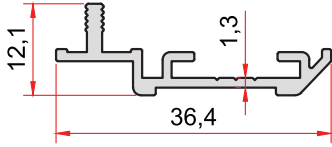

**KOD-CODE** TEORİK AĞIRLIK  
1107 0,238 Kg/m  
THEORETICAL WEIGHT

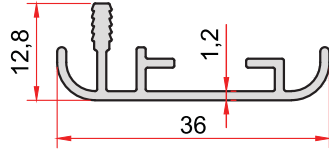

**KOD-CODE** TEORİK AĞIRLIK  
1030 0,254 Kg/m  
THEORETICAL WEIGHT

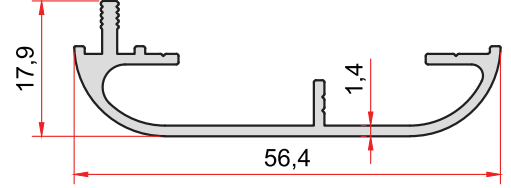

**KOD-CODE** TEORİK AĞIRLIK  
1106 0,421 Kg/m  
THEORETICAL WEIGHT

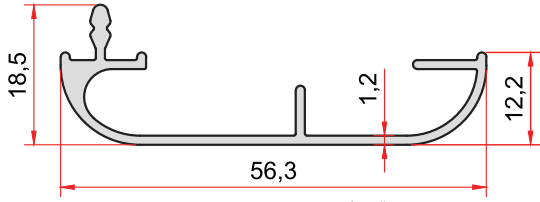

**KOD-CODE** TEORİK AĞIRLIK  
1038 0,373 Kg/m  
THEORETICAL WEIGHT

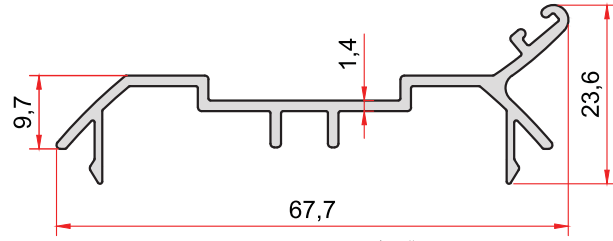

**KOD-CODE** TEORİK AĞIRLIK  
1034 0,464 Kg/m  
THEORETICAL WEIGHT

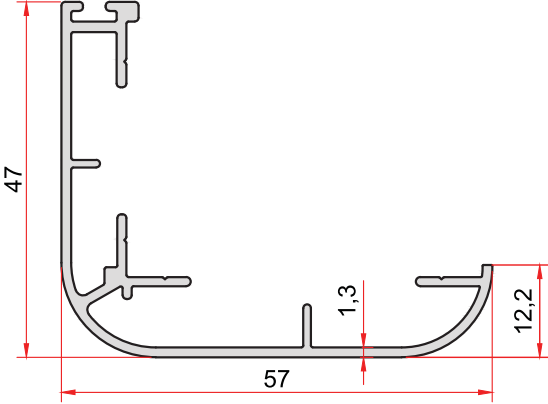

**KOD-CODE** TEORİK AĞIRLIK  
1019 0,588 Kg/m  
THEORETICAL WEIGHT

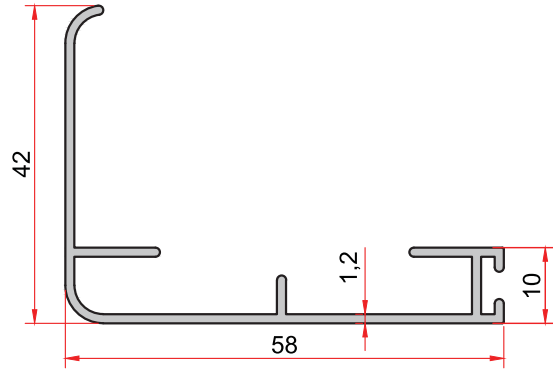

**KOD-CODE** TEORİK AĞIRLIK  
1090 0,449 Kg/m  
THEORETICAL WEIGHT

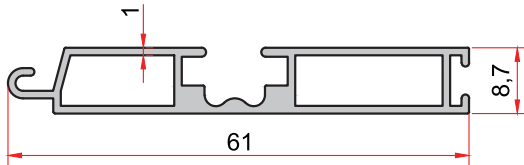

**KOD-CODE** TEORİK AĞIRLIK  
1093 0,437 Kg/m  
THEORETICAL WEIGHT

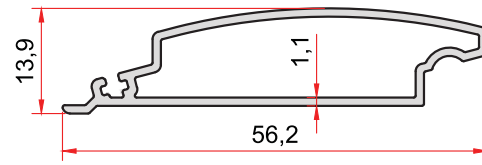

**KOD-CODE** TEORİK AĞIRLIK  
1015 0,365 Kg/m  
THEORETICAL WEIGHT

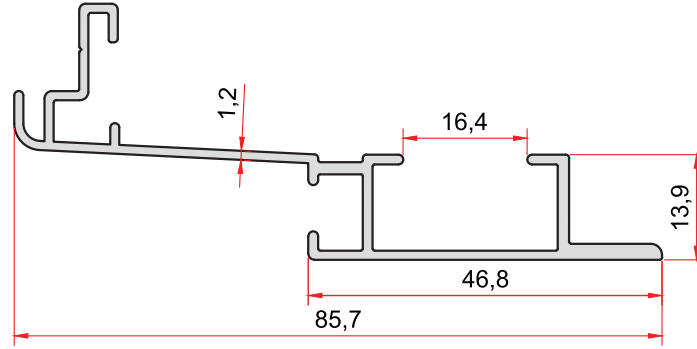

**KOD-CODE**    *TEORİK AĞIRLIK*  
*THEORETICAL WEIGHT*  
**1080**        **0,600 Kg/m**

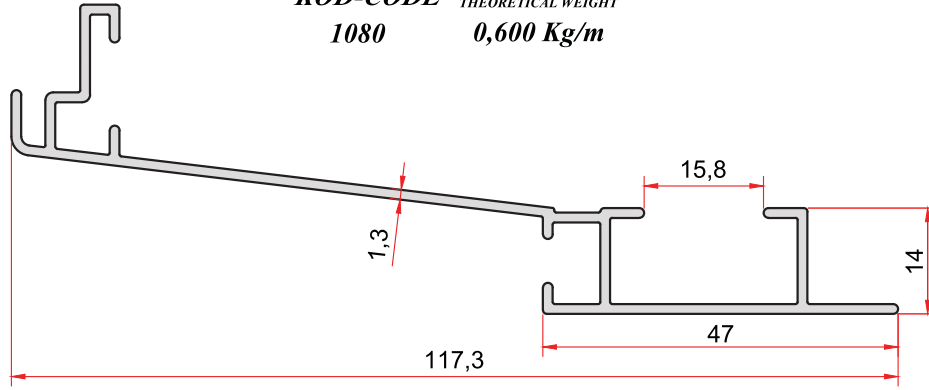

**KOD-CODE**    *TEORİK AĞIRLIK*  
*THEORETICAL WEIGHT*  
**1016**        **0,721 Kg/m**

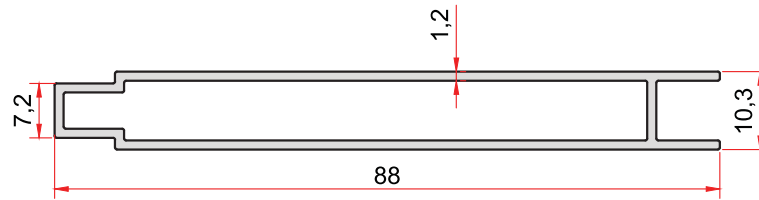

**KOD-CODE**    *TEORİK AĞIRLIK*  
*THEORETICAL WEIGHT*  
**1035**        **0,622 Kg/m**

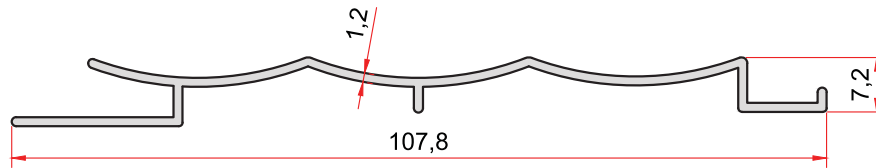

**KOD-CODE**    *TEORİK AĞIRLIK*  
*THEORETICAL WEIGHT*  
**1108**        **0,443 Kg/m**

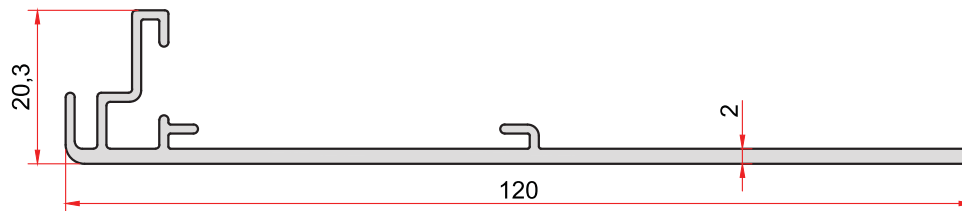

**KOD-CODE**    *TEORİK AĞIRLIK*  
*THEORETICAL WEIGHT*  
**1031**        **0,813 Kg/m**

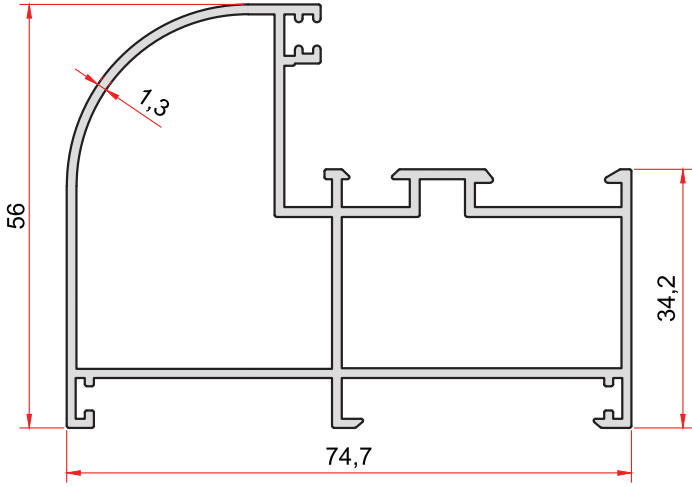

**KOD-CODE** *TEORİK AĞIRLIK*  
*THEORETICAL WEIGHT*  
**1119** **1,129 Kg/m**

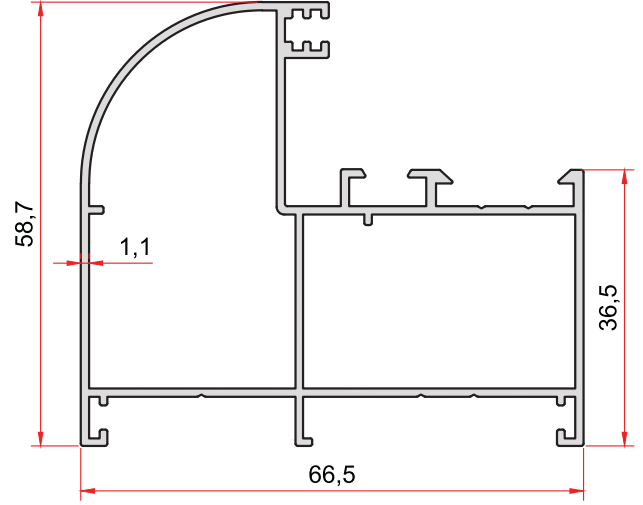

**KOD-CODE** *TEORİK AĞIRLIK*  
*THEORETICAL WEIGHT*  
**1129** **0,937 Kg/m**

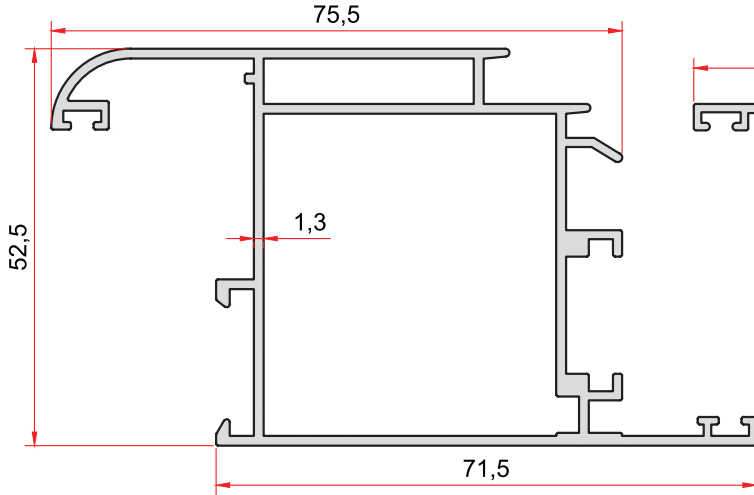

**KOD-CODE** *TEORİK AĞIRLIK*  
*THEORETICAL WEIGHT*  
**1121** **1,199 Kg/m**

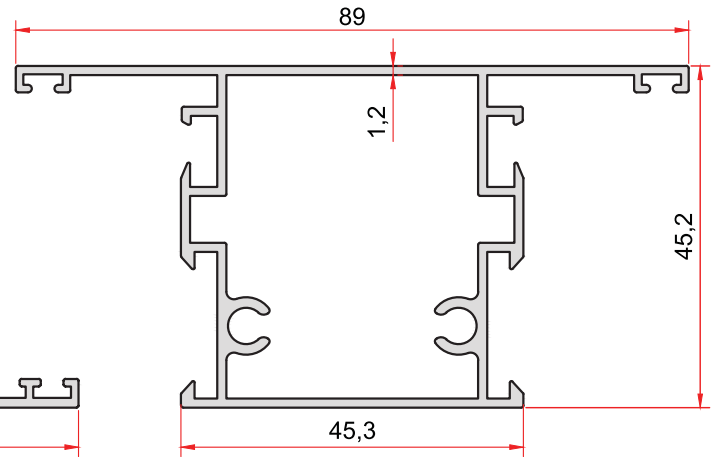

**KOD-CODE** *TEORİK AĞIRLIK*  
*THEORETICAL WEIGHT*  
**1153** **0,994 Kg/m**

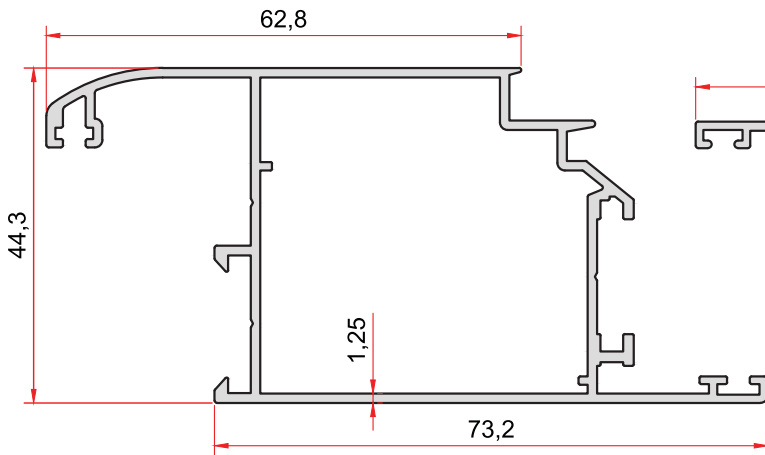

**KOD-CODE** *TEORİK AĞIRLIK*  
*THEORETICAL WEIGHT*  
**1130** **0,961 Kg/m**

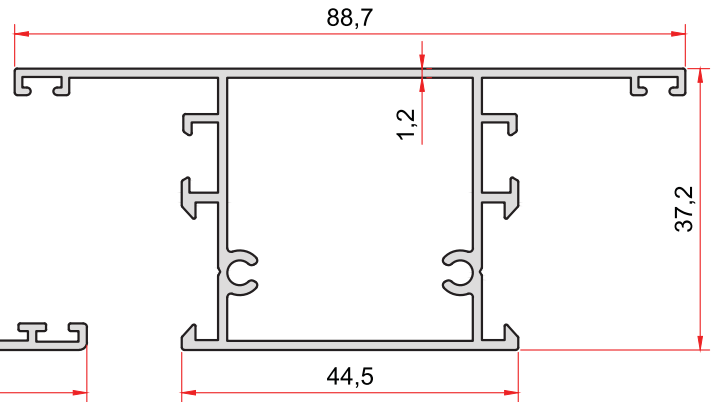

**KOD-CODE** *TEORİK AĞIRLIK*  
*THEORETICAL WEIGHT*  
**1132** **0,859 Kg/m**



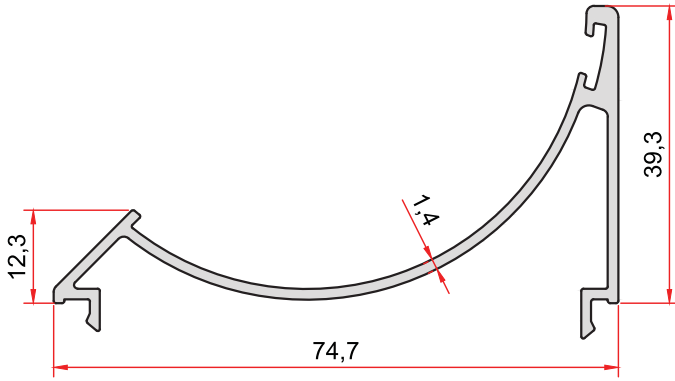

**KOD-CODE** *TEORİK AĞIRLIK*  
**1202** *THEORETICAL WEIGHT*  
**0,621 Kg/m**

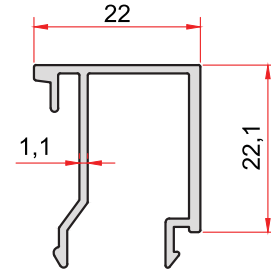

**KOD-CODE** *TEORİK AĞIRLIK*  
**1120** *THEORETICAL WEIGHT*  
**0,278 Kg/m**

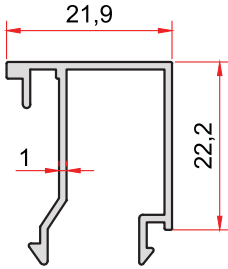

**KOD-CODE** *TEORİK AĞIRLIK*  
**1131** *THEORETICAL WEIGHT*  
**0,240 Kg/m**

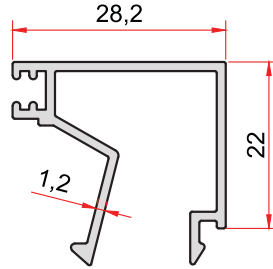

**KOD-CODE** *TEORİK AĞIRLIK*  
**1145** *THEORETICAL WEIGHT*  
**0,324 Kg/m**

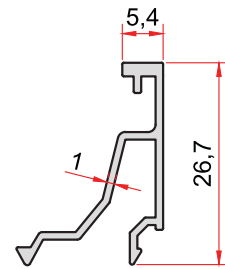

**KOD-CODE** *TEORİK AĞIRLIK*  
**1133** *THEORETICAL WEIGHT*  
**0,189 Kg/m**

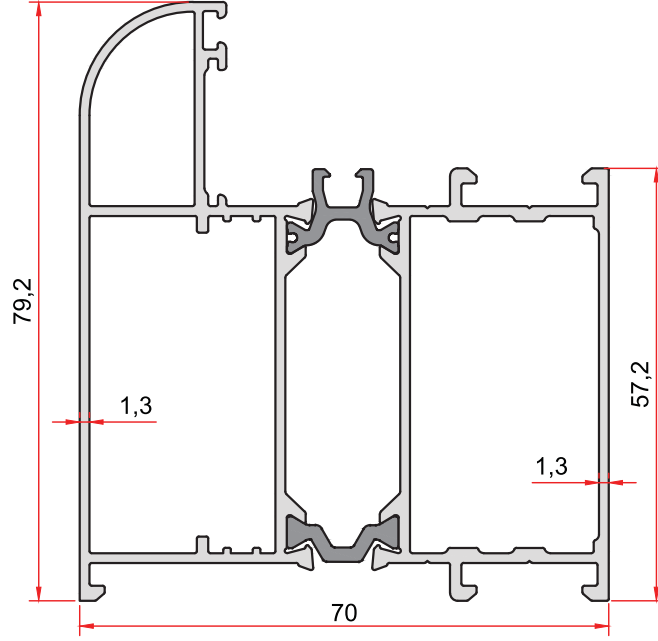

**KOD-CODE** TEORİK AĞIRLIK  
**AT-7002-13** THEORETICAL WEIGHT  
**1,757 Kg/m**

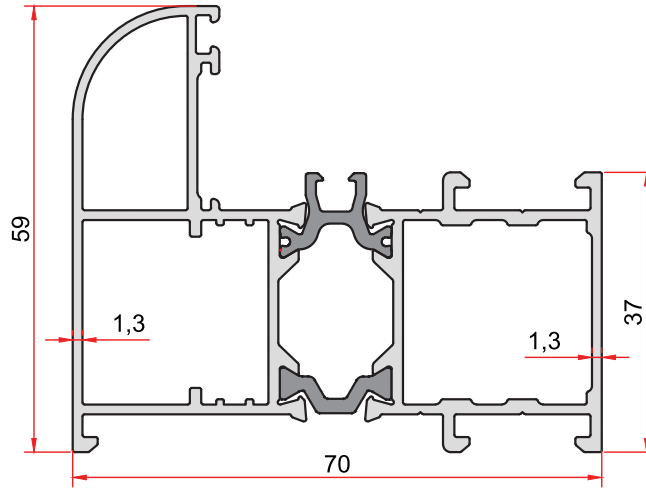

**KOD-CODE** TEORİK AĞIRLIK  
**AT-7001-13** THEORETICAL WEIGHT  
**1,473 Kg/m**

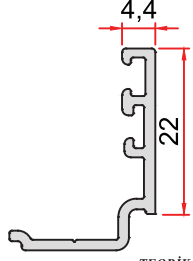

**KOD-CODE** TEORİK AĞIRLIK  
THEORETICAL WEIGHT  
**CC-1044-15** 0,212 Kg/m

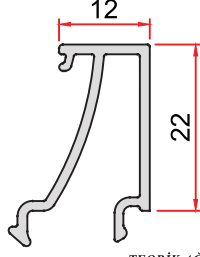

**KOD-CODE** TEORİK AĞIRLIK  
THEORETICAL WEIGHT  
**CC-1120-13** 0,254 Kg/m

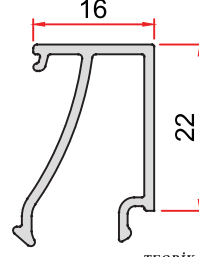

**KOD-CODE** TEORİK AĞIRLIK  
THEORETICAL WEIGHT  
**CC-1160-13** 0,260 Kg/m

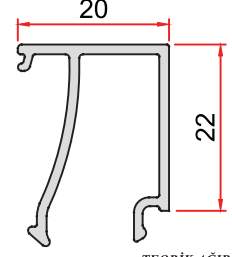

**KOD-CODE** TEORİK AĞIRLIK  
THEORETICAL WEIGHT  
**CC-1200-13** 0,270 Kg/m

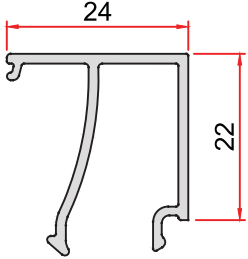

**KOD-CODE** TEORİK AĞIRLIK  
THEORETICAL WEIGHT  
**CC-1240-13** 0,285 Kg/m

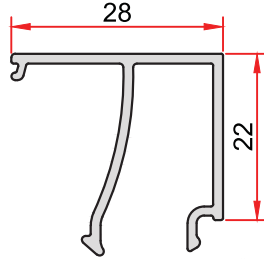

**KOD-CODE** TEORİK AĞIRLIK  
THEORETICAL WEIGHT  
**CC-1180-13** 0,300 Kg/m

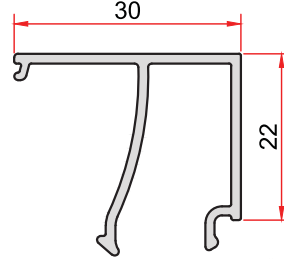

**KOD-CODE** TEORİK AĞIRLIK  
THEORETICAL WEIGHT  
**CC-1300-13** 0,305 Kg/m

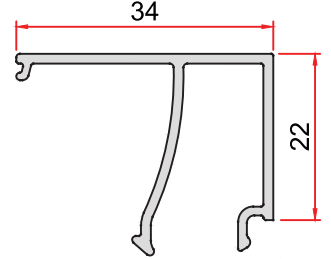

**KOD-CODE** TEORİK AĞIRLIK  
THEORETICAL WEIGHT  
**CC-1340-13** 0,320 Kg/m

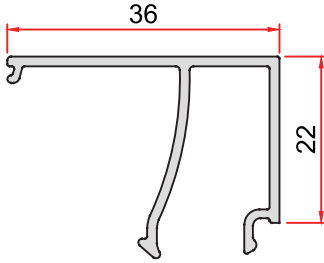

**KOD-CODE** TEORİK AĞIRLIK  
THEORETICAL WEIGHT  
**CC-1360-13** 0,327 Kg/m

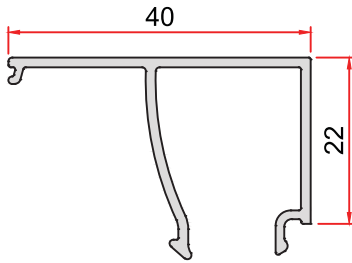

**KOD-CODE** TEORİK AĞIRLIK  
THEORETICAL WEIGHT  
**CC-1400-13** 0,341 Kg/m

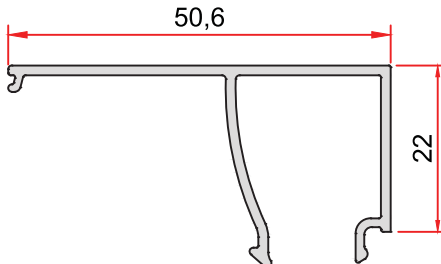

**KOD-CODE** TEORİK AĞIRLIK  
THEORETICAL WEIGHT  
**CC-1506-13** 0,378 Kg/m

CAM ÖLÇÜSÜ	PROFİL KOD-CODE	FİTİL KOD	
8 mm	CC-1400-13	AC1-02	AC2-03
10 mm	CC-1400-13	AC1-02	AC2-01
12 mm	CC-1360-13	AC1-02	AC2-03
16 mm	CC-1340-13	AC1-02	AC2-01
20 mm	CC-1280-13	AC1-02	AC2-03
22 mm	CC-1280-13	AC1-02	AC2-01
24 mm	CC-1240-13	AC1-02	AC2-03
26 mm	CC-1240-13	AC1-02	AC2-01
30 mm	CC-1200-13	AC1-02	AC2-03
32 mm	CC-1200-13	AC1-02	AC2-01
34 mm	CC-1160-13	AC1-02	AC2-03
36 mm	CC-1160-13	AC1-02	AC2-01
38 mm	CC-1120-13	AC1-02	AC2-03
40 mm	CC-1120-13	AC1-02	AC2-01
48 mm	CC-1144-13	AC1-02	AC2-01
50 mm	CC-1144-13	AC1-02	AC2-01

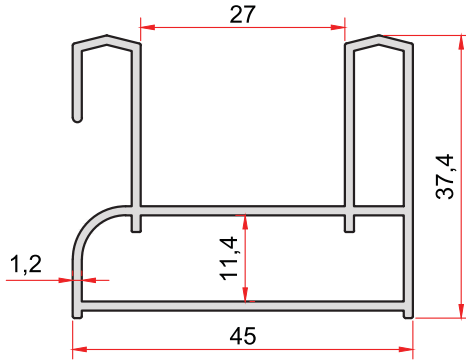

**KOD-CODE** *TEORİK AĞIRLIK*  
*THEORETICAL WEIGHT*  
**1123** **0,664 Kg/m**

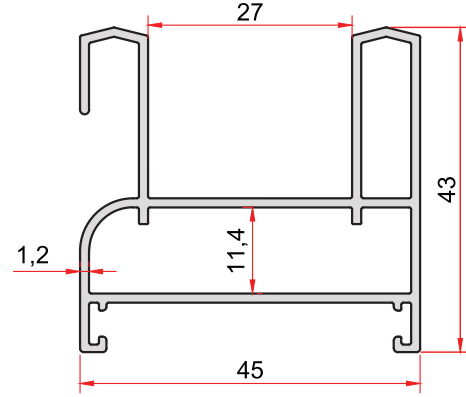

**KOD-CODE** *TEORİK AĞIRLIK*  
*THEORETICAL WEIGHT*  
**1191** **0,723 Kg/m**

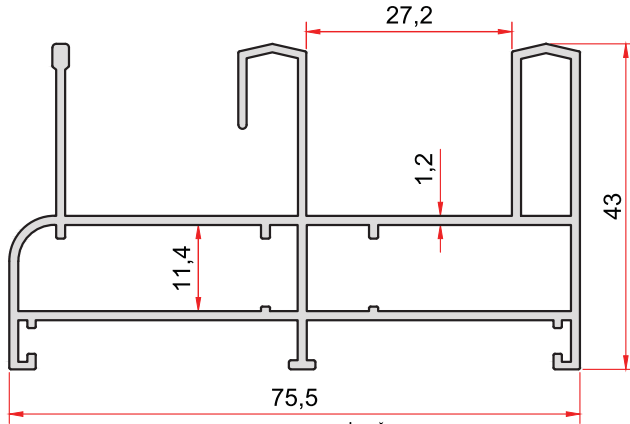

**KOD-CODE** *TEORİK AĞIRLIK*  
*THEORETICAL WEIGHT*  
**1065** **1,069 Kg/m**

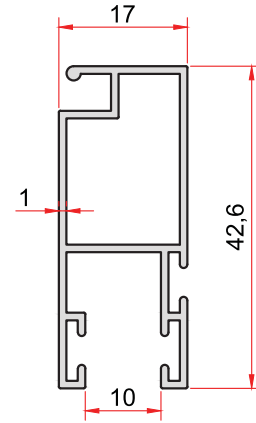

**KOD-CODE** *TEORİK AĞIRLIK*  
*THEORETICAL WEIGHT*  
**1066** **0,389 Kg/m**

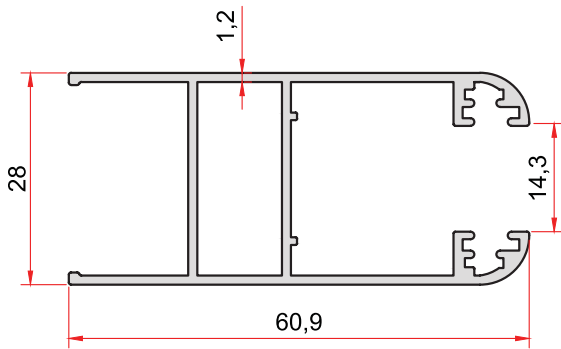

**KOD-CODE** *TEORİK AĞIRLIK*  
*THEORETICAL WEIGHT*  
**1067** **0,680 Kg/m**

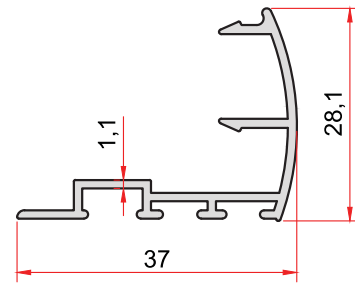

**KOD-CODE** *TEORİK AĞIRLIK*  
*THEORETICAL WEIGHT*  
**1068** **0,286 Kg/m**

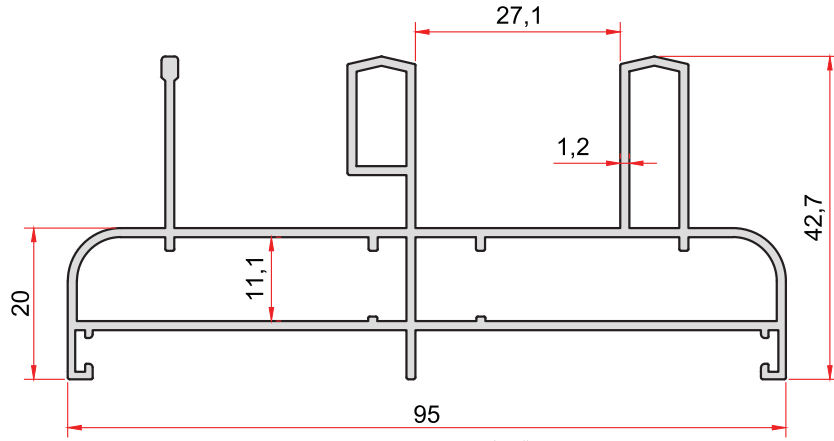

**KOD-CODE** *TEORİK AĞIRLIK*  
*THEORETICAL WEIGHT*  
**1134** **1,218 Kg/m**

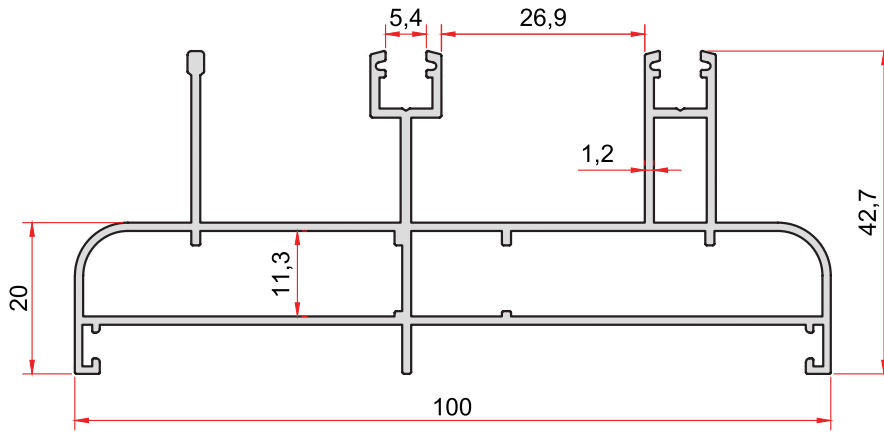

**KOD-CODE** *TEORİK AĞIRLIK*  
*THEORETICAL WEIGHT*  
**1138** **1,182 Kg/m**

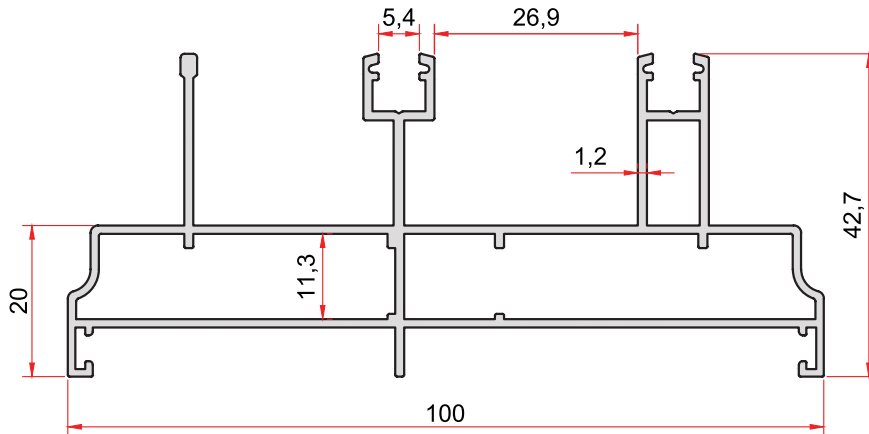

**KOD-CODE** *TEORİK AĞIRLIK*  
*THEORETICAL WEIGHT*  
**1139** **1,188 Kg/m**

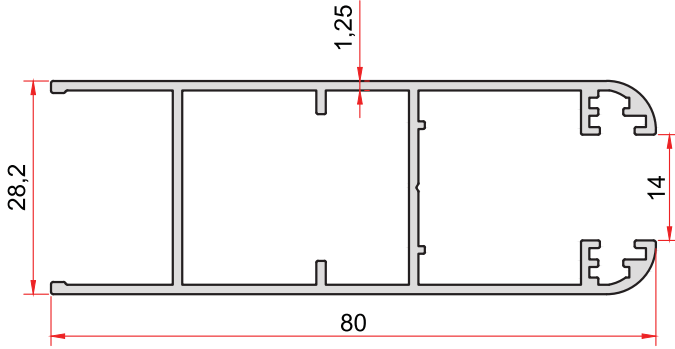

**KOD-CODE** TEORİK AĞIRLIK  
THEORETICAL WEIGHT  
**1135** **0,848 Kg/m**

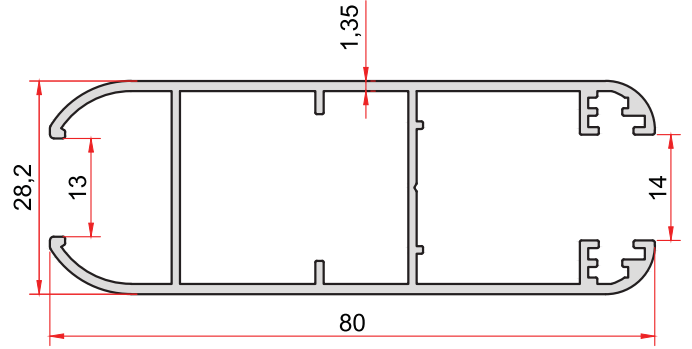

**KOD-CODE** TEORİK AĞIRLIK  
THEORETICAL WEIGHT  
**1136** **0,880 Kg/m**

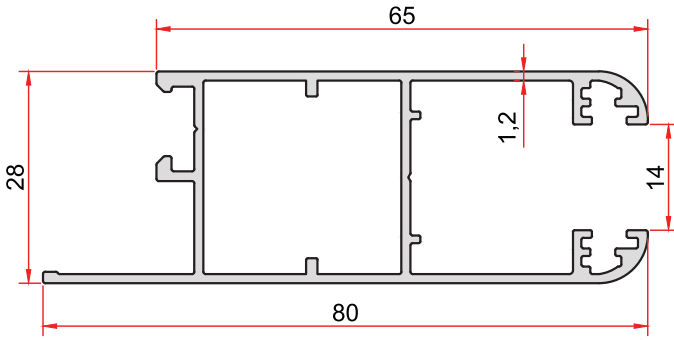

**KOD-CODE** TEORİK AĞIRLIK  
THEORETICAL WEIGHT  
**1204** **0,810 Kg/m**

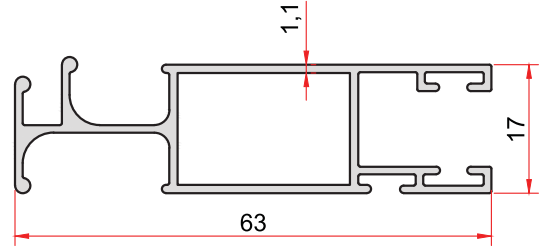

**KOD-CODE** TEORİK AĞIRLIK  
THEORETICAL WEIGHT  
**1311** **0,548 Kg/m**

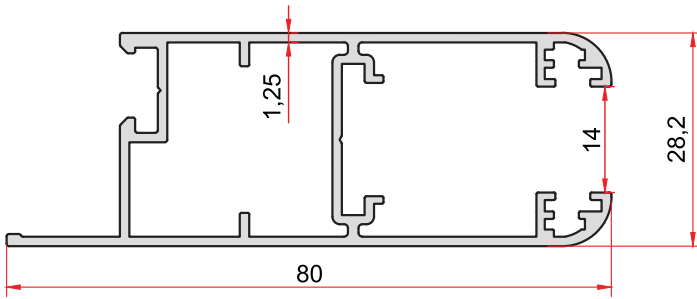

**KOD-CODE** TEORİK AĞIRLIK  
THEORETICAL WEIGHT  
**7026** **0,880 Kg/m**

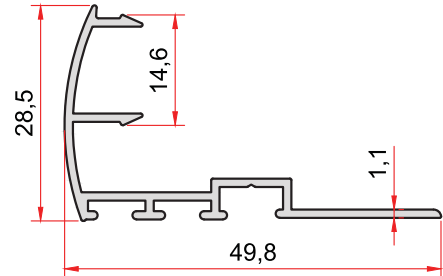

**KOD-CODE** TEORİK AĞIRLIK  
THEORETICAL WEIGHT  
**1137** **0,324 Kg/m**

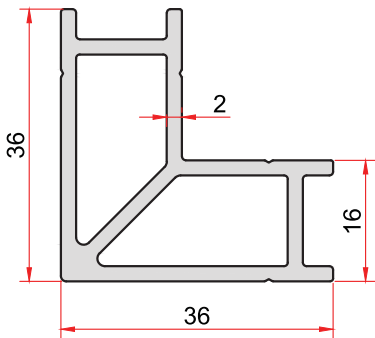

**KOD-CODE** TEORİK AĞIRLIK  
THEORETICAL WEIGHT  
**1160** **0,831 Kg/m**

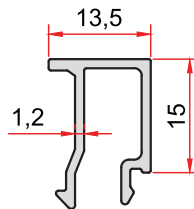

**KOD-CODE** TEORİK AĞIRLIK  
THEORETICAL WEIGHT  
**1205** **0,181 Kg/m**

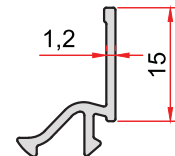

**KOD-CODE** TEORİK AĞIRLIK  
THEORETICAL WEIGHT  
**1206** **0,119 Kg/m**

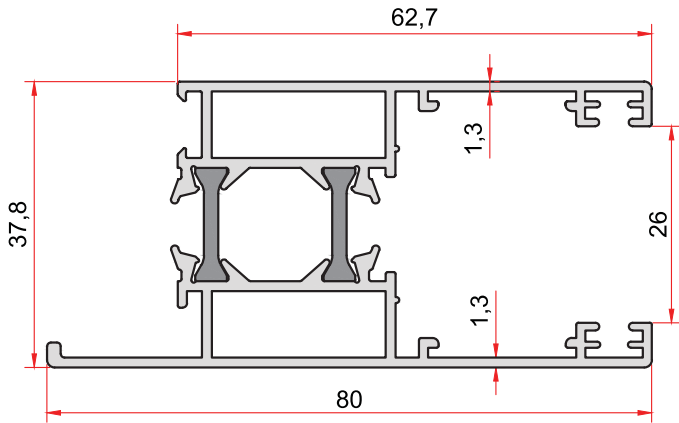

**KOD-CODE** *TEORİK AĞIRLIK*  
*THEORETICAL WEIGHT*  
**SS-203-13** **1,239 Kg/m**

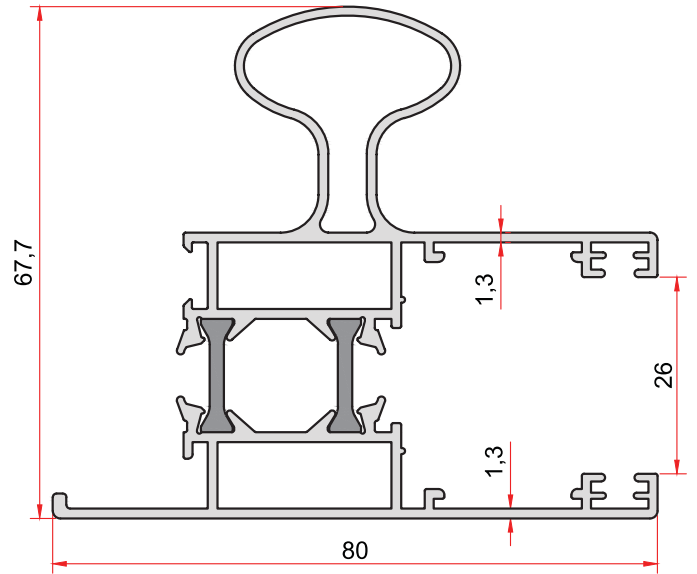

**KOD-CODE** *TEORİK AĞIRLIK*  
*THEORETICAL WEIGHT*  
**SS-204-13** **1,556 Kg/m**

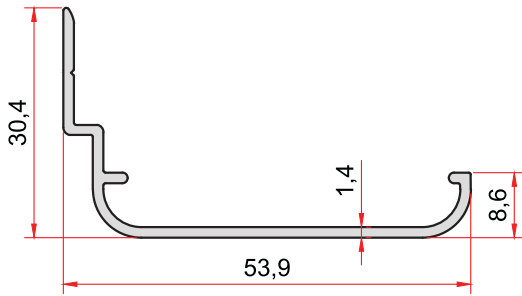

**KOD-CODE** *TEORİK AĞIRLIK*  
*THEORETICAL WEIGHT*  
**SS-403-14** **0,335 Kg/m**

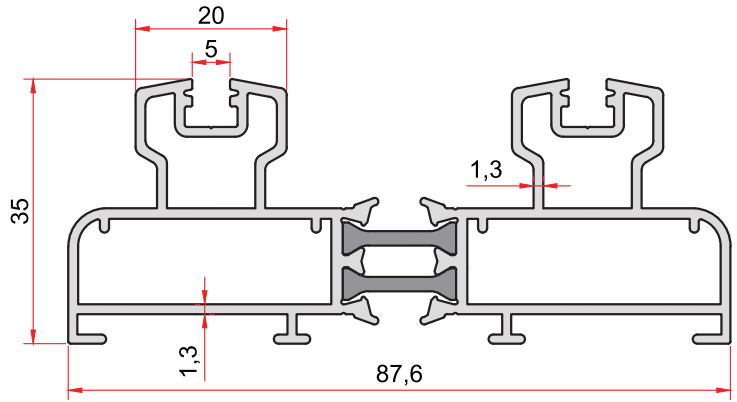

**KOD-CODE** *TEORİK AĞIRLIK*  
*THEORETICAL WEIGHT*  
**SS-103-13** **1,529 Kg/m**

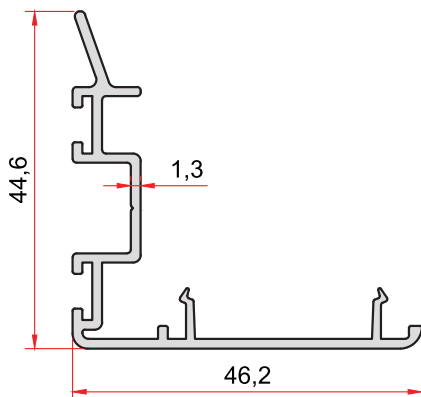

**KOD-CODE** *TEORİK AĞIRLIK*  
*THEORETICAL WEIGHT*  
**SS-404-13** **0,468 Kg/m**

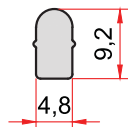

**KOD-CODE** *TEORİK AĞIRLIK*  
*THEORETICAL WEIGHT*  
**SS-502-00** **0,113 Kg/m**

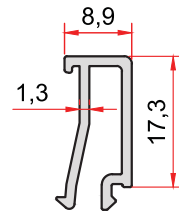

**KOD-CODE** *TEORİK AĞIRLIK*  
*THEORETICAL WEIGHT*  
**SS-303-13** **0,179 Kg/m**

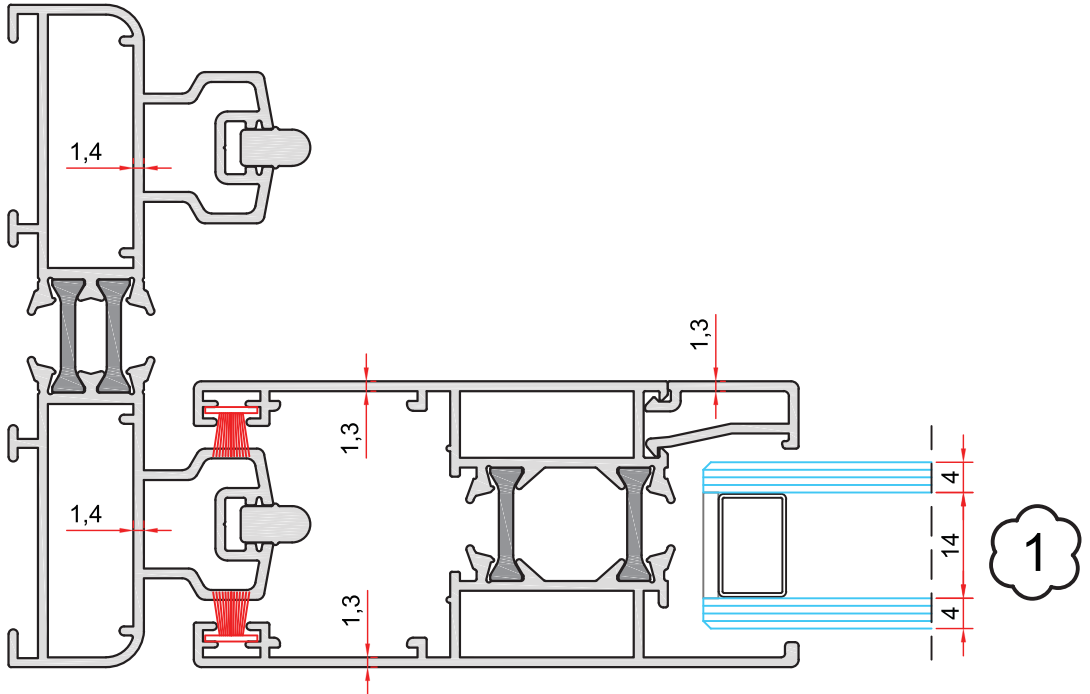
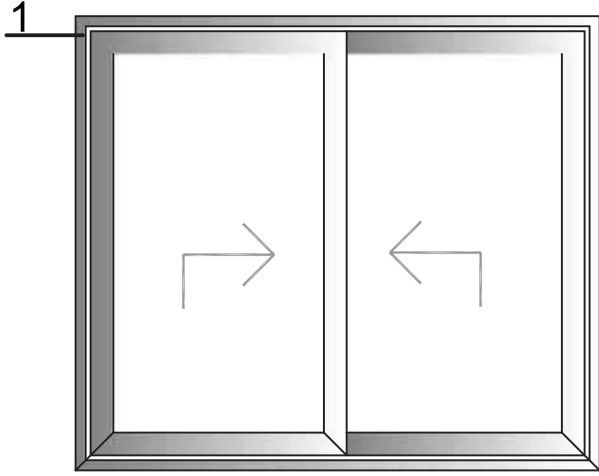



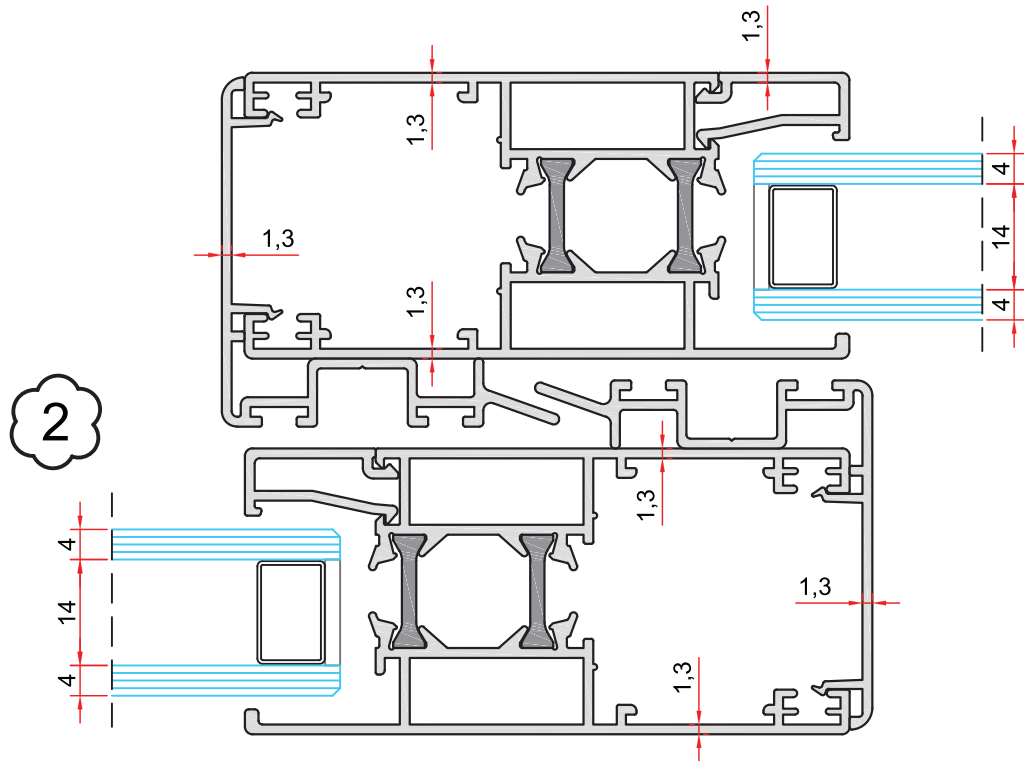
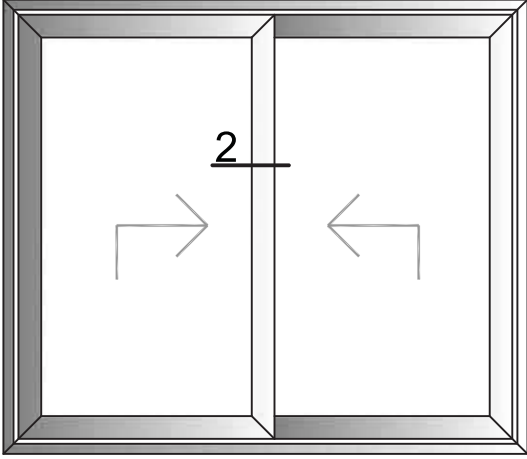

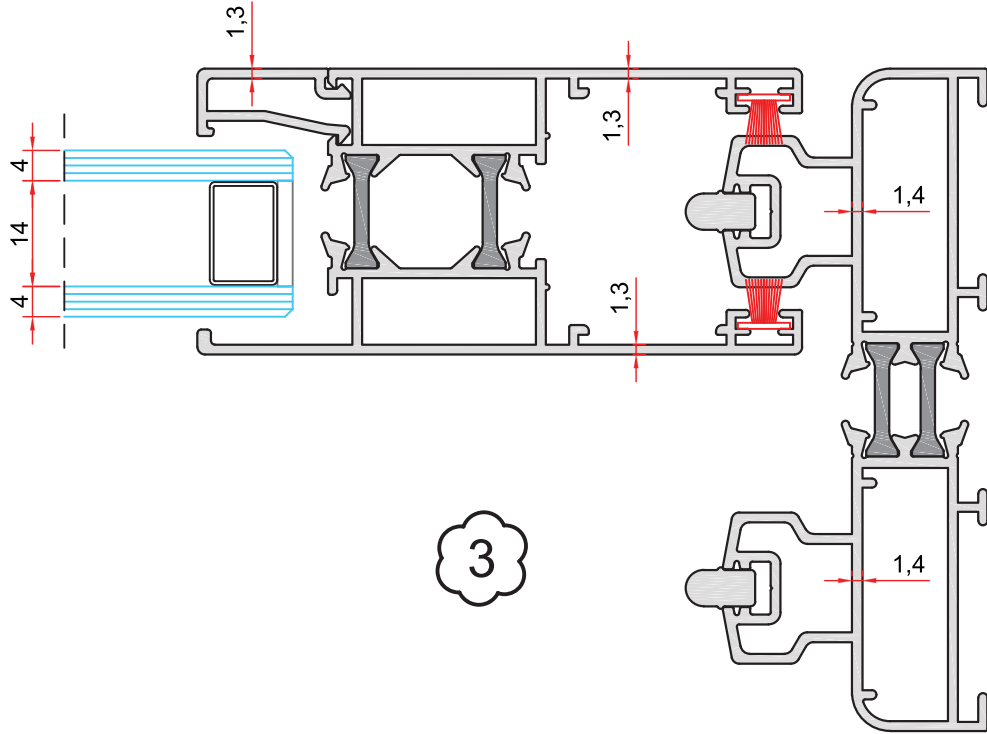
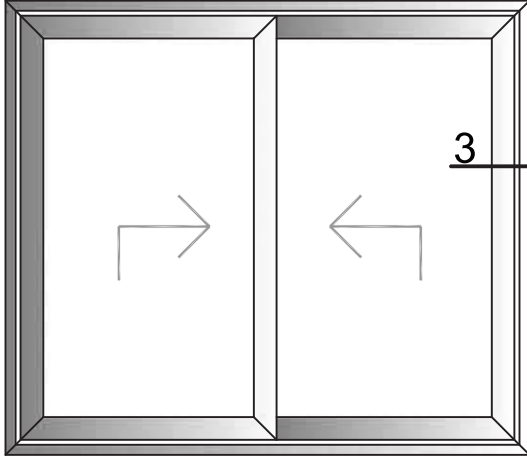

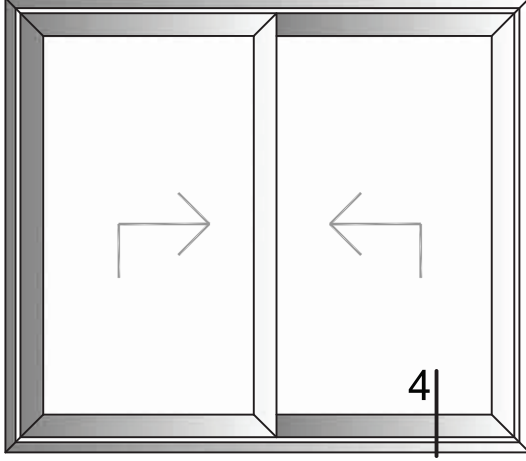

4

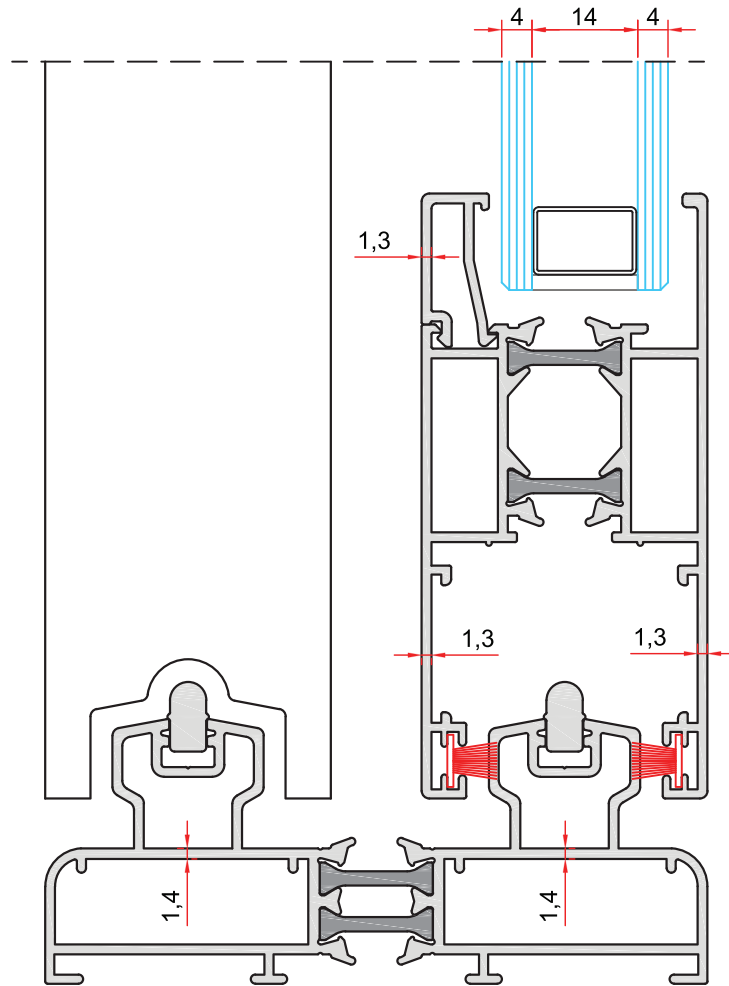

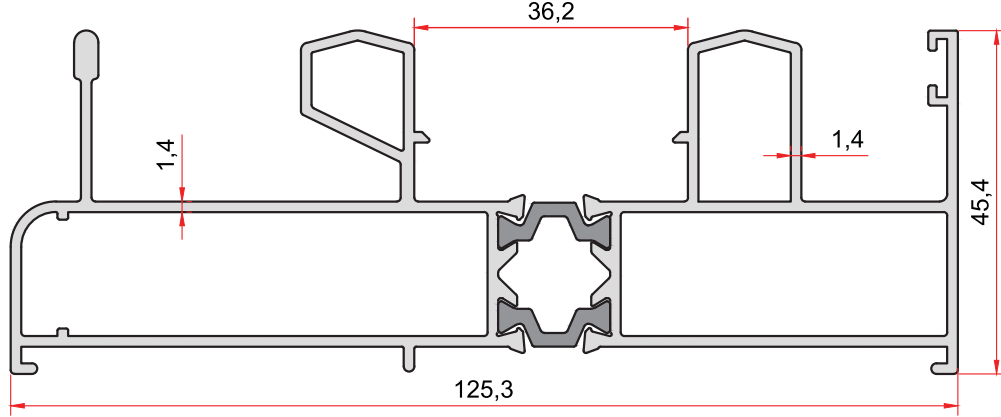

**KOD-CODE** TEORİK AĞIRLIK  
**SS-101-14** THEORETICAL WEIGHT  
**2,054 Kg/m**

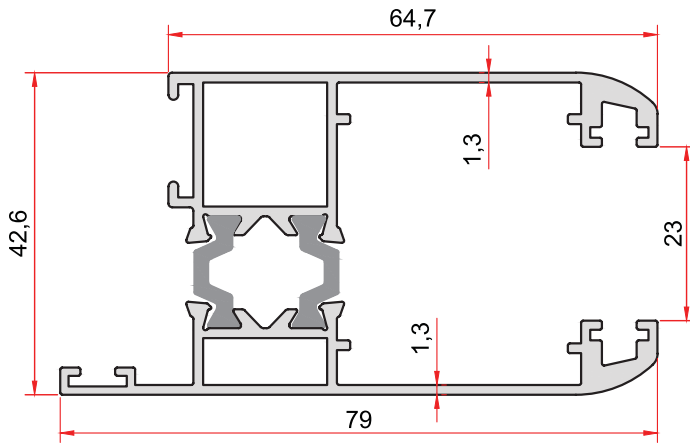

**KOD-CODE** TEORİK AĞIRLIK  
**SS-201-13** THEORETICAL WEIGHT  
**1,341 Kg/m**

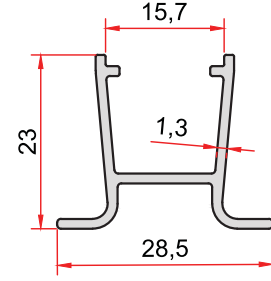

**KOD-CODE** TEORİK AĞIRLIK  
**SS-501-13** THEORETICAL WEIGHT  
**0,262 Kg/m**

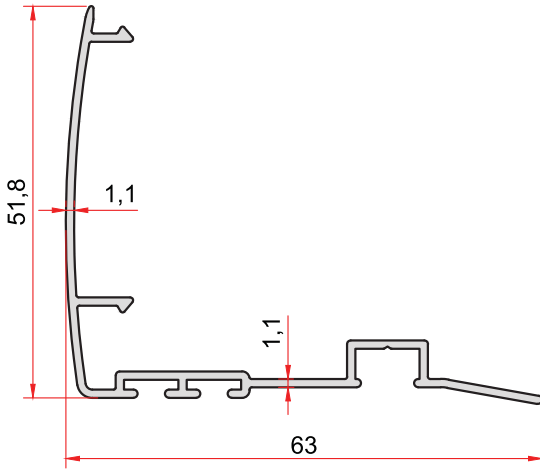

**KOD-CODE** TEORİK AĞIRLIK  
**KS-4514-11** THEORETICAL WEIGHT  
**0,448 Kg/m**

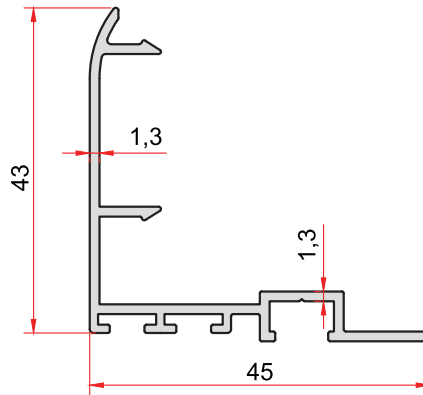

**KOD-CODE** TEORİK AĞIRLIK  
**SS-401-13** THEORETICAL WEIGHT  
**0,432 Kg/m**

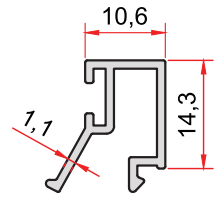

**KOD-CODE** TEORİK AĞIRLIK  
**SS-301-11** THEORETICAL WEIGHT  
**0,165 Kg/m**

# Doğrama Profilleri

## Yalıtım Sürme Seri

**ARFEM**<sup>®</sup>  
ALÜMİNYUM

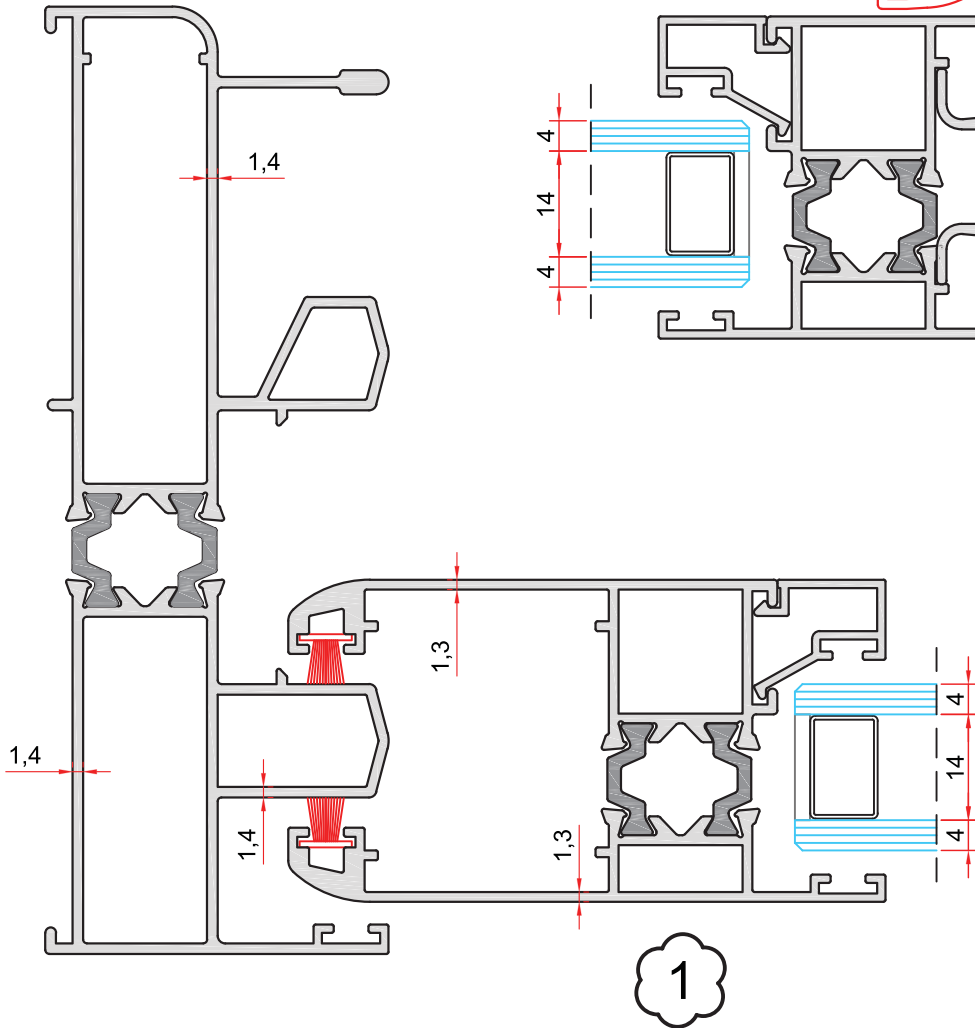
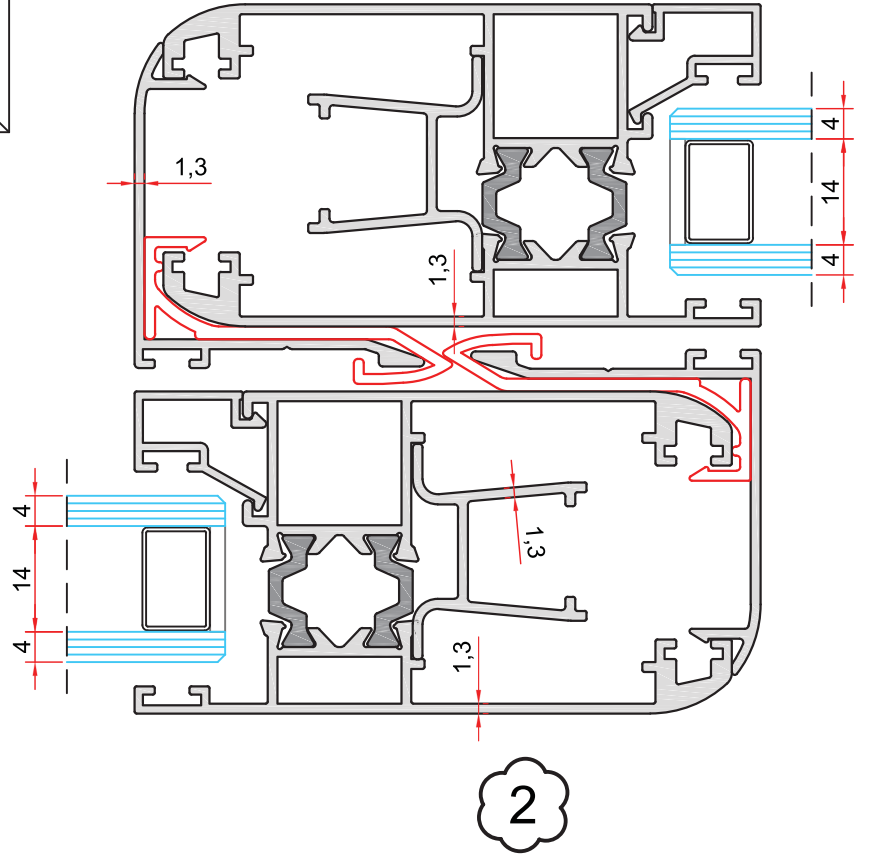
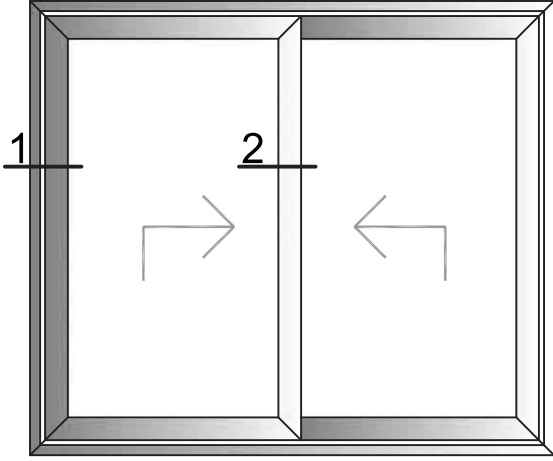

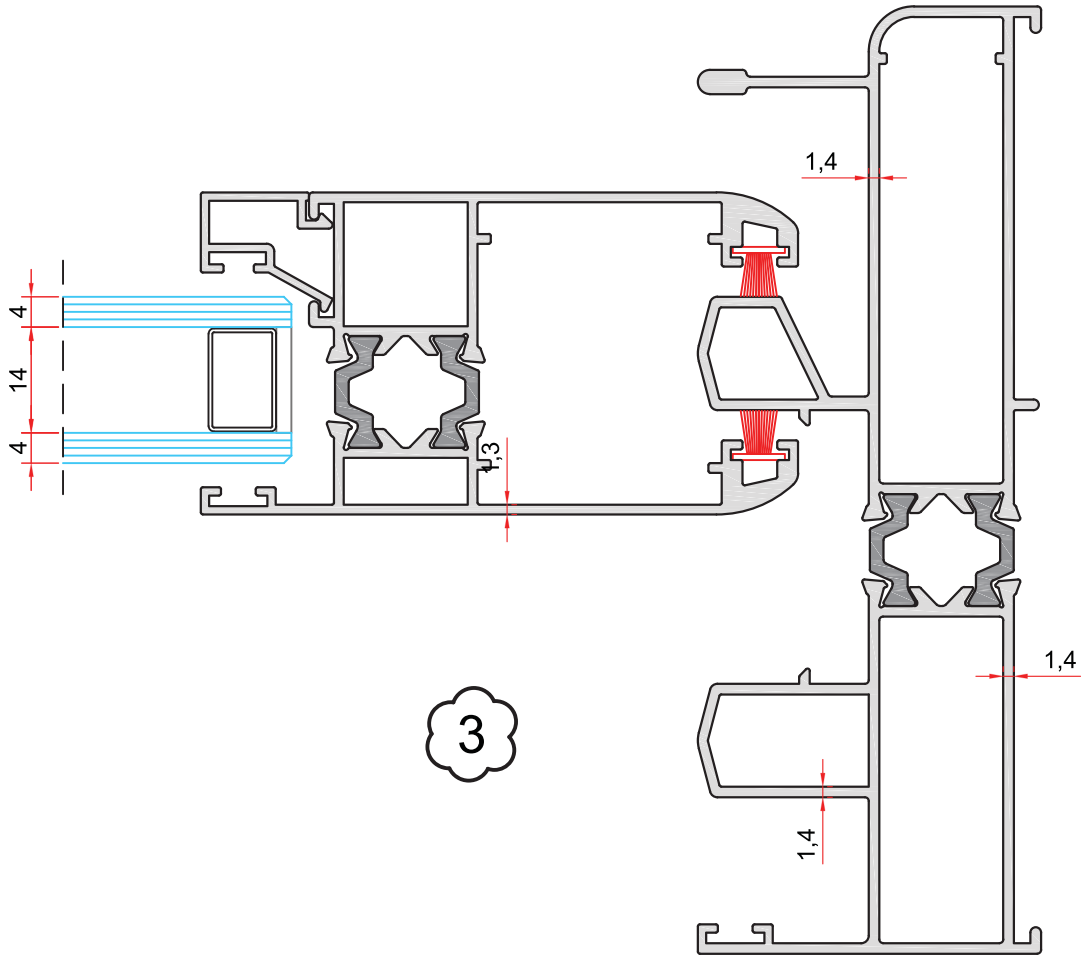
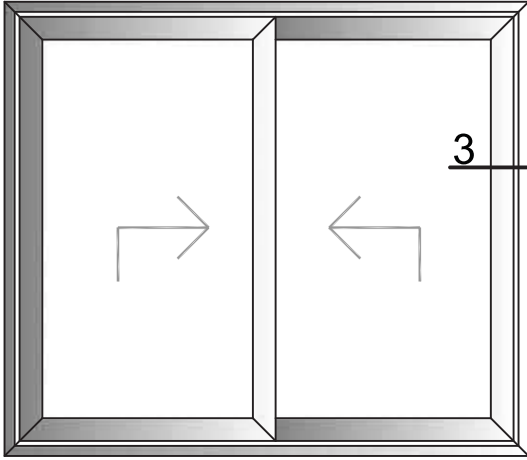

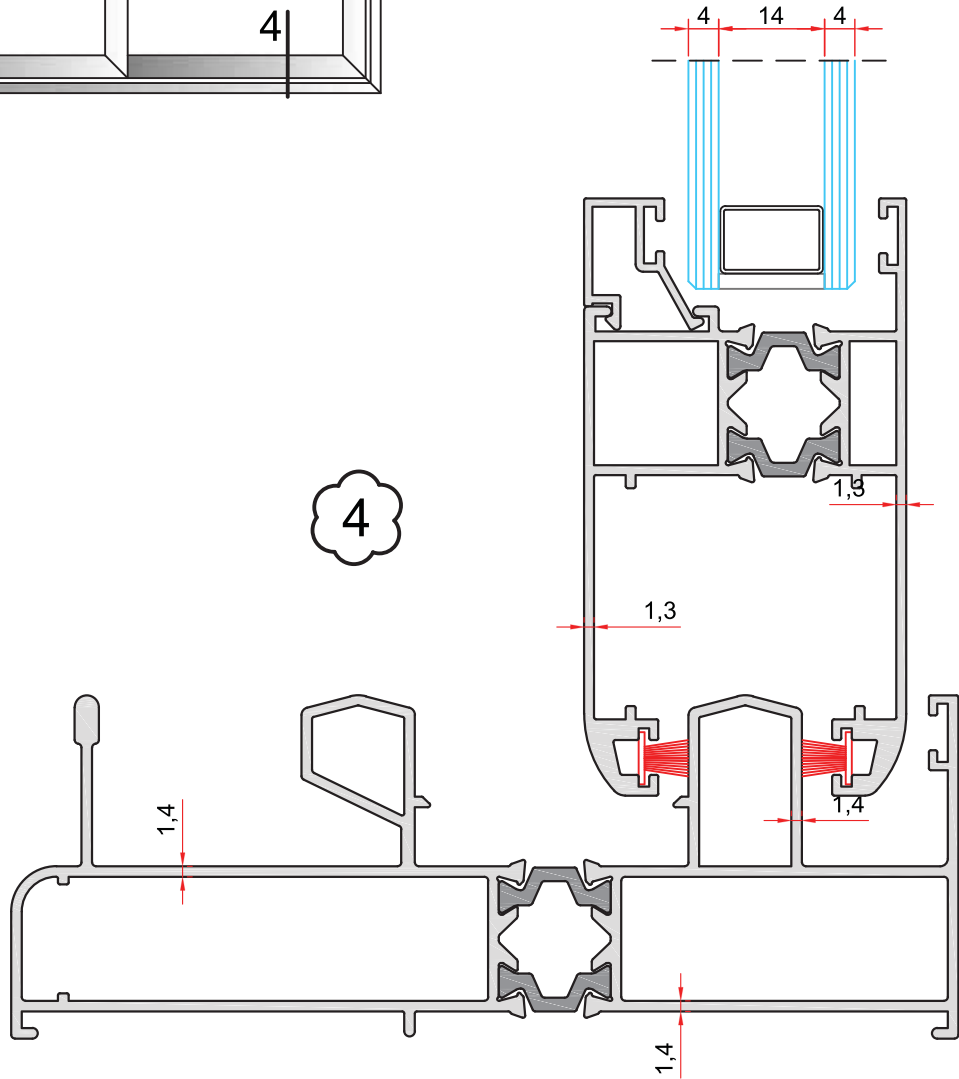
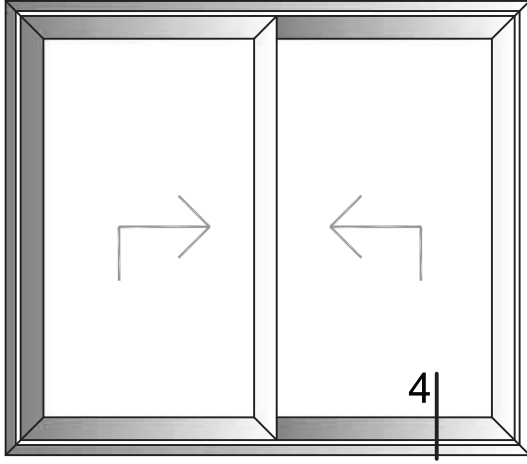

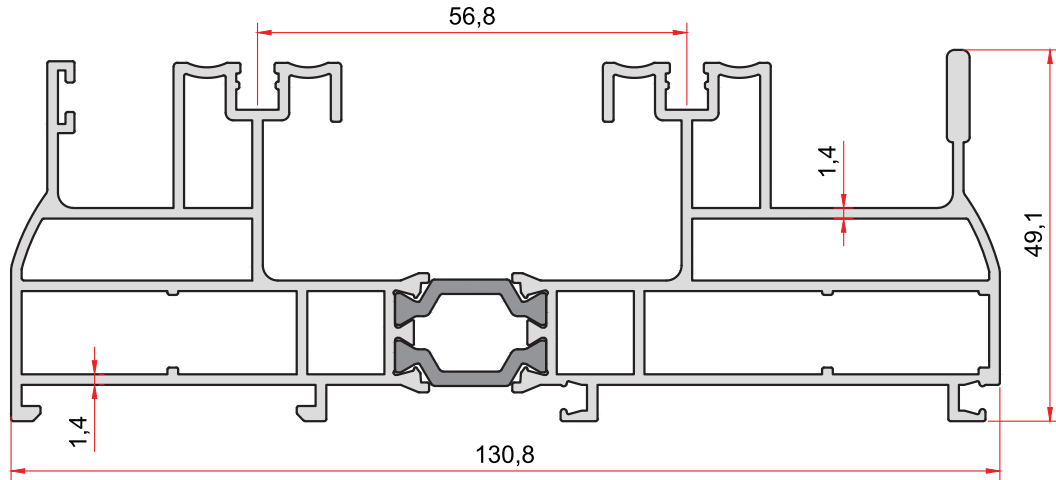

**KOD-CODE** TEORİK AĞIRLIK  
THEORETICAL WEIGHT  
**SS-102-14** 2,678 Kg/m

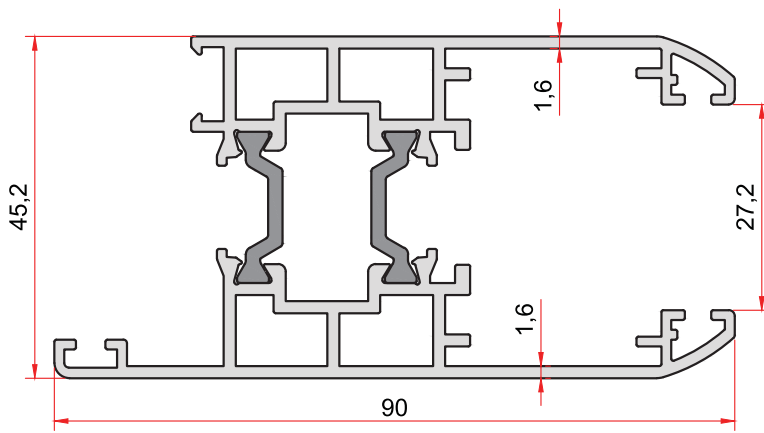

**KOD-CODE** TEORİK AĞIRLIK  
THEORETICAL WEIGHT  
**SS-202-16** 1,786 Kg/m

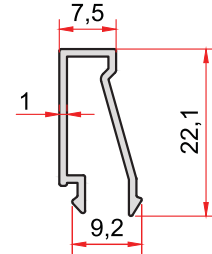

**KOD-CODE** TEORİK AĞIRLIK  
THEORETICAL WEIGHT  
**SS-602-10** 0,145 Kg/m

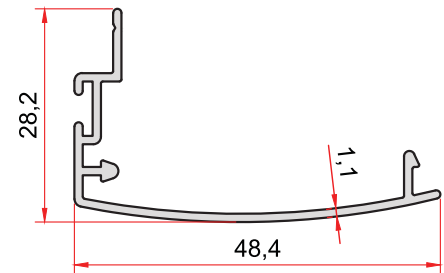

**KOD-CODE** TEORİK AĞIRLIK  
THEORETICAL WEIGHT  
**SS-402-11** 0,289 Kg/m

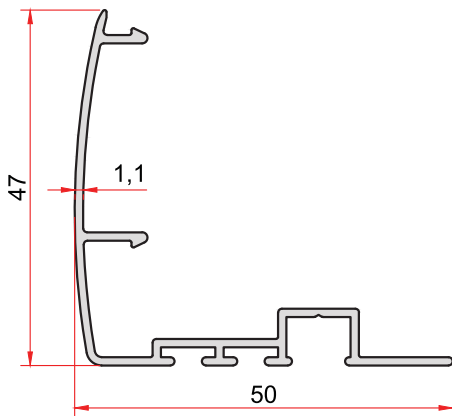

**KOD-CODE** TEORİK AĞIRLIK  
THEORETICAL WEIGHT  
**SS-602-11** 0,402 Kg/m

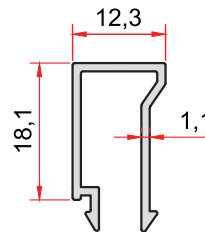

**KOD-CODE** TEORİK AĞIRLIK  
THEORETICAL WEIGHT  
**SS-302-11** 0,176 Kg/m

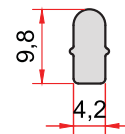

**KOD-CODE** TEORİK AĞIRLIK  
THEORETICAL WEIGHT  
**SS-501-00** 0,108 Kg/m



# Doğrama Profilleri

## Yalıtımlı Sürme Seri

**ARFEM**<sup>®</sup>  
ALÜMİNYUM

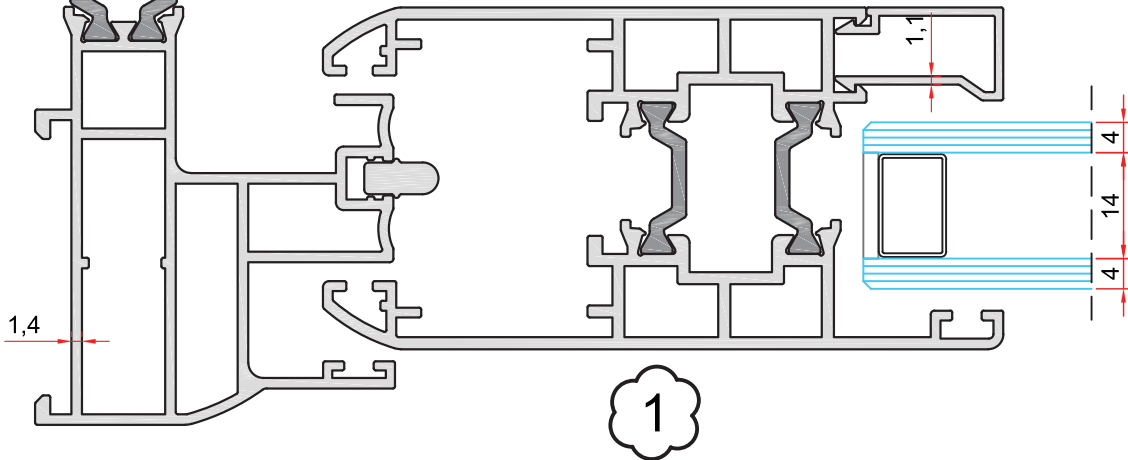
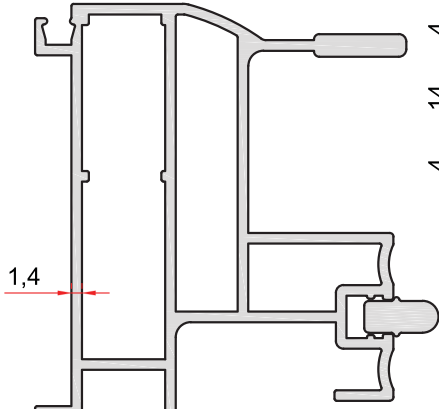
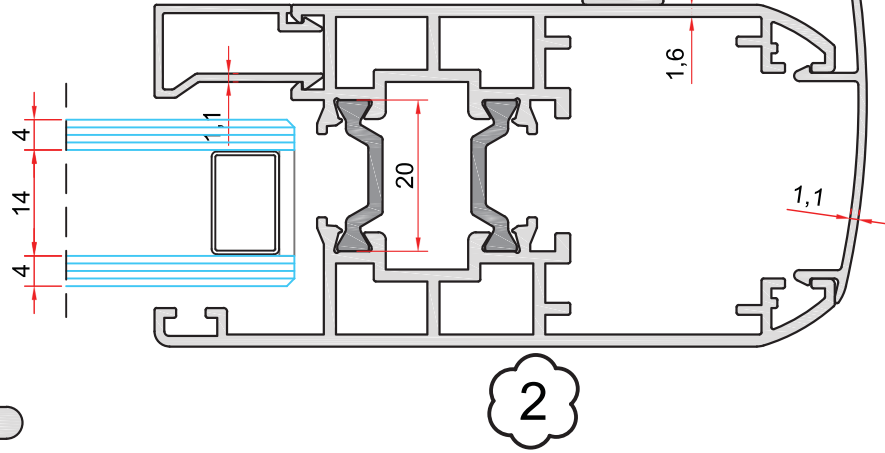
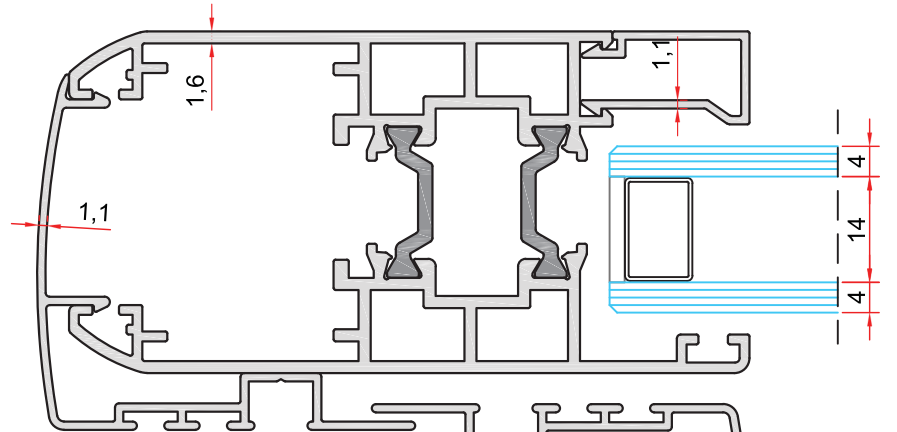
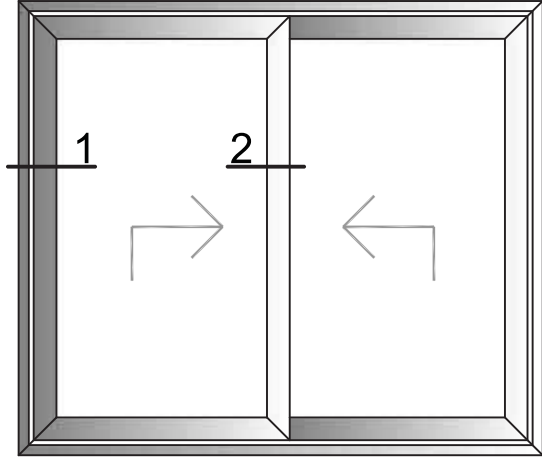

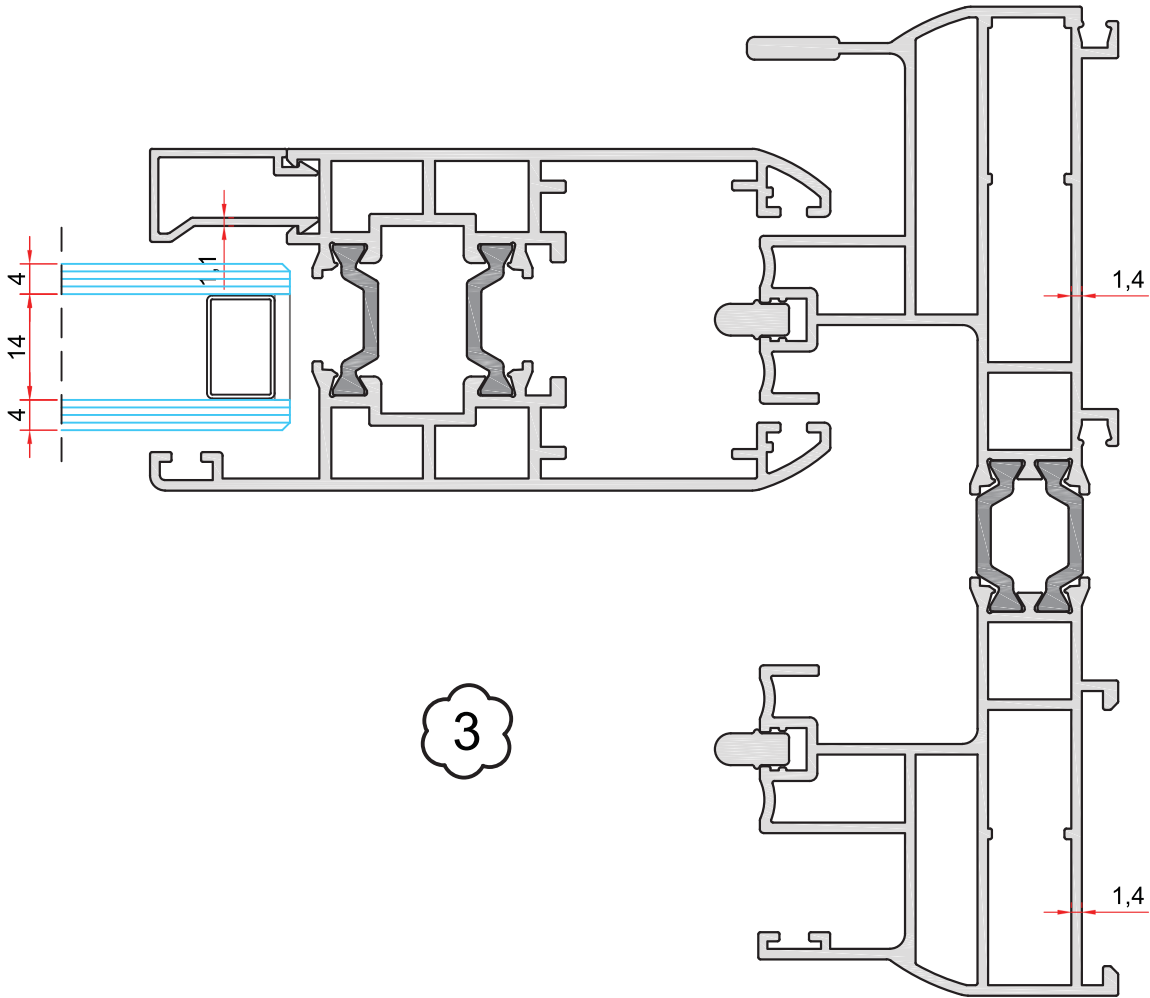
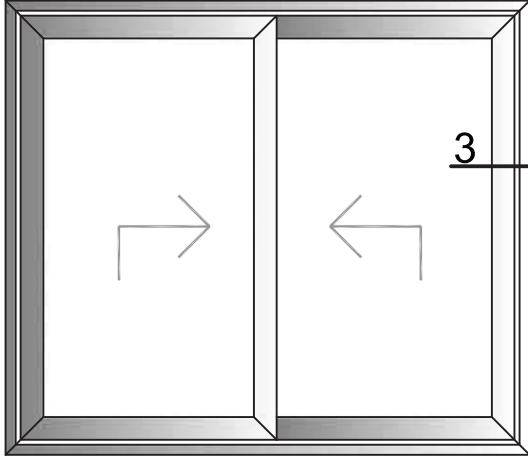

# Doğrama Profilleri

## Yalıtımlı Sürme Seri

**ARFEM**<sup>®</sup>  
ALÜMİNYUM

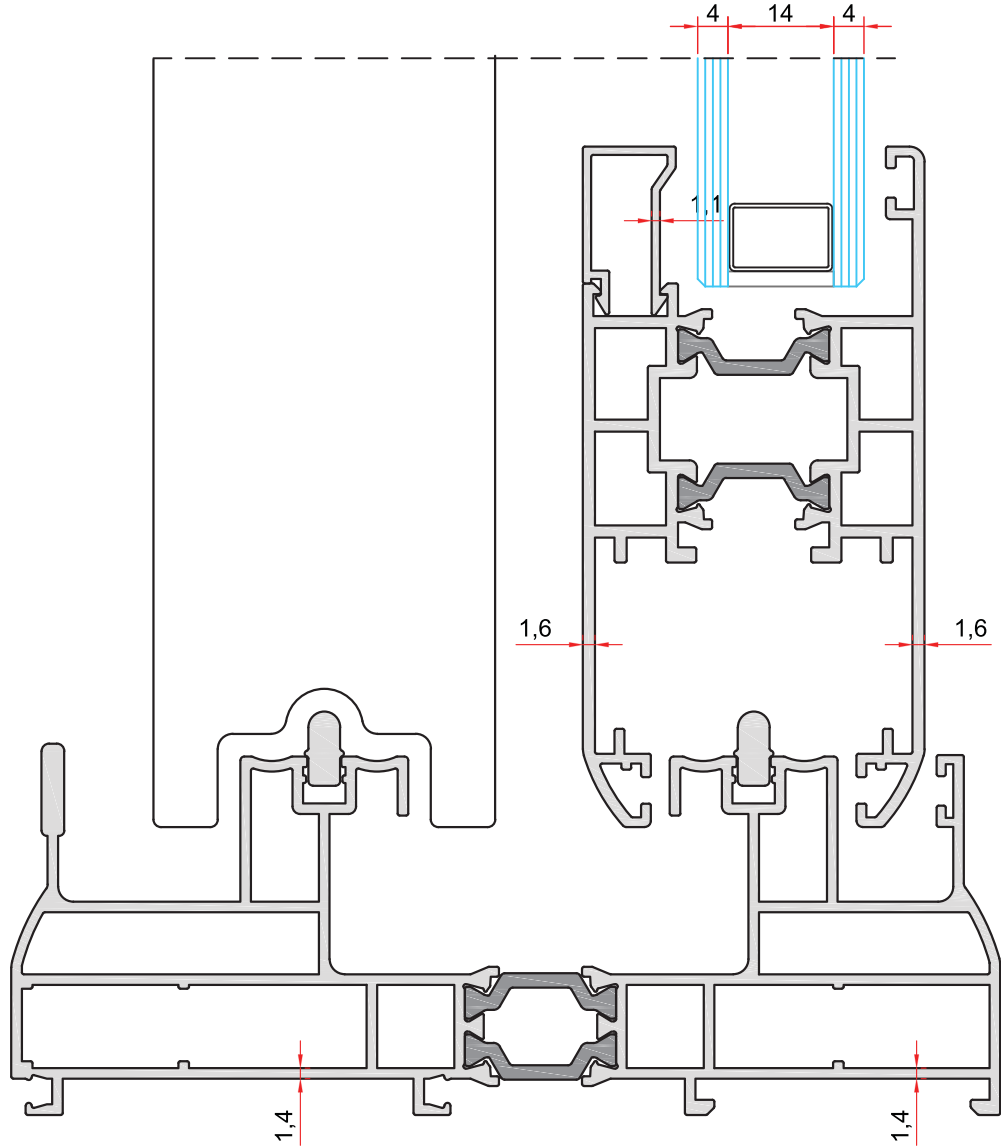
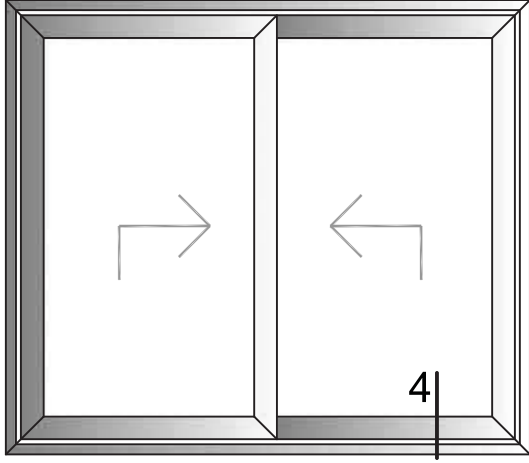

4

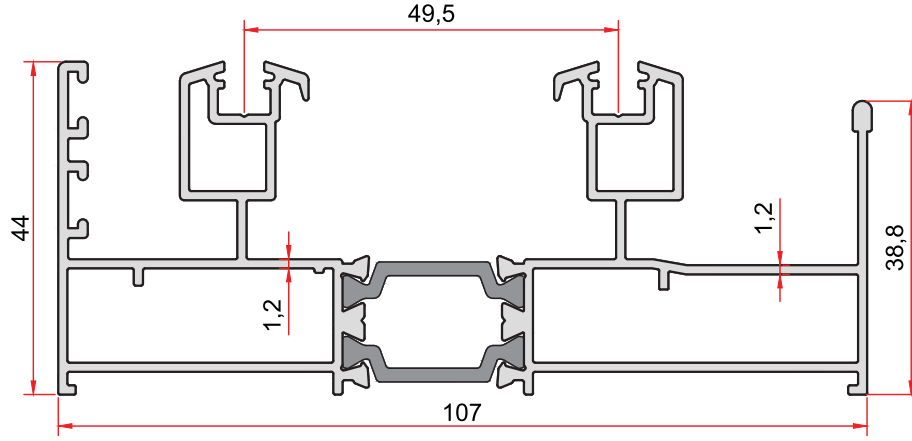

**KOD-CODE**      **TEORİK AĞIRLIK**  
**MD-103-12**      **THEORETICAL WEIGHT**  
**1,825 Kg/m**

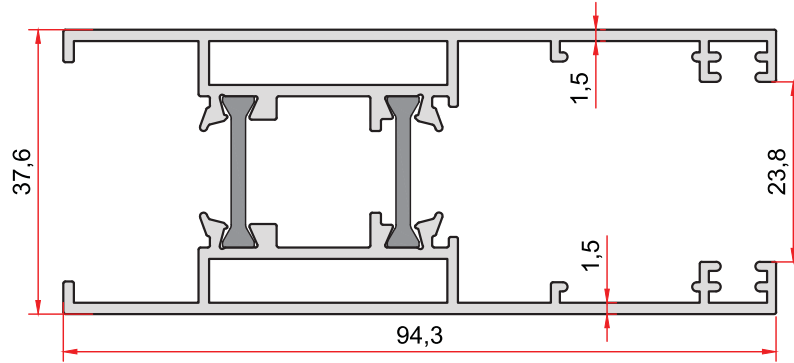

**KOD-CODE**      **TEORİK AĞIRLIK**  
**MD-101-15**      **THEORETICAL WEIGHT**  
**1,616 Kg/m**

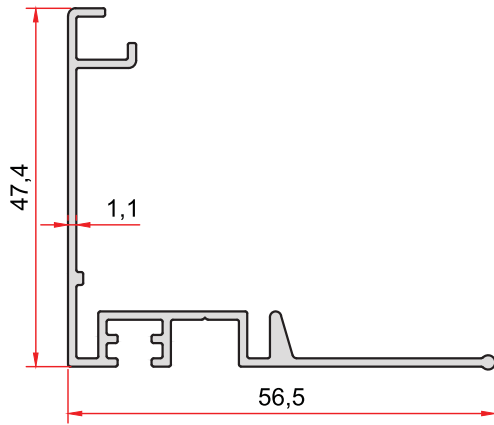

**KOD-CODE**      **TEORİK AĞIRLIK**  
**MD-102-11**      **THEORETICAL WEIGHT**  
**0,461 Kg/m**

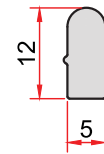

**KOD-CODE**      **TEORİK AĞIRLIK**  
**MD-104-00**      **THEORETICAL WEIGHT**  
**0,156 Kg/m**

## Doğrama Profilleri Yalıtımlı Sürme Seri

**ARFEM**<sup>®</sup>  
ALÜMİNYUM

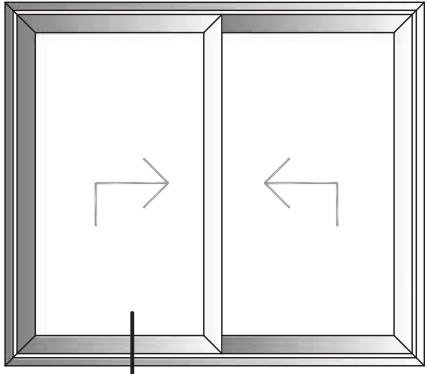

1

Yalıtımlı Dar Sürme Pencere

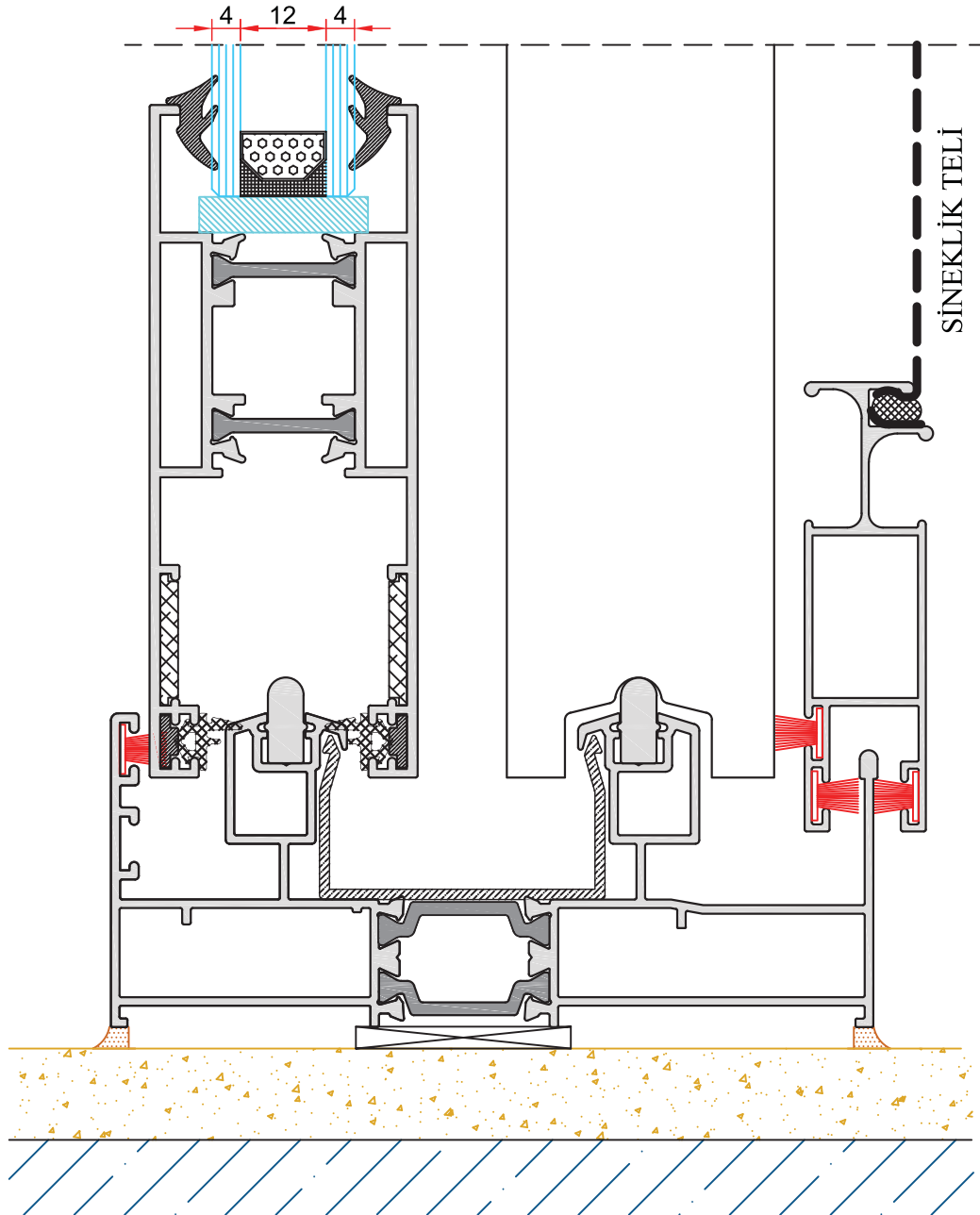

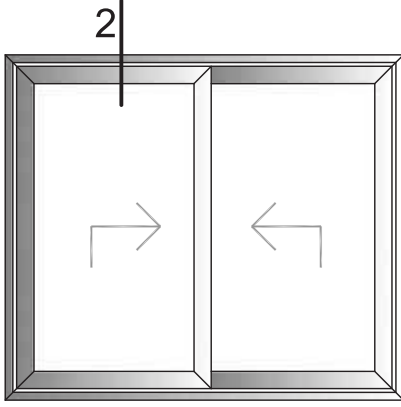

Yalıtımlı Dar Sürme Pencere

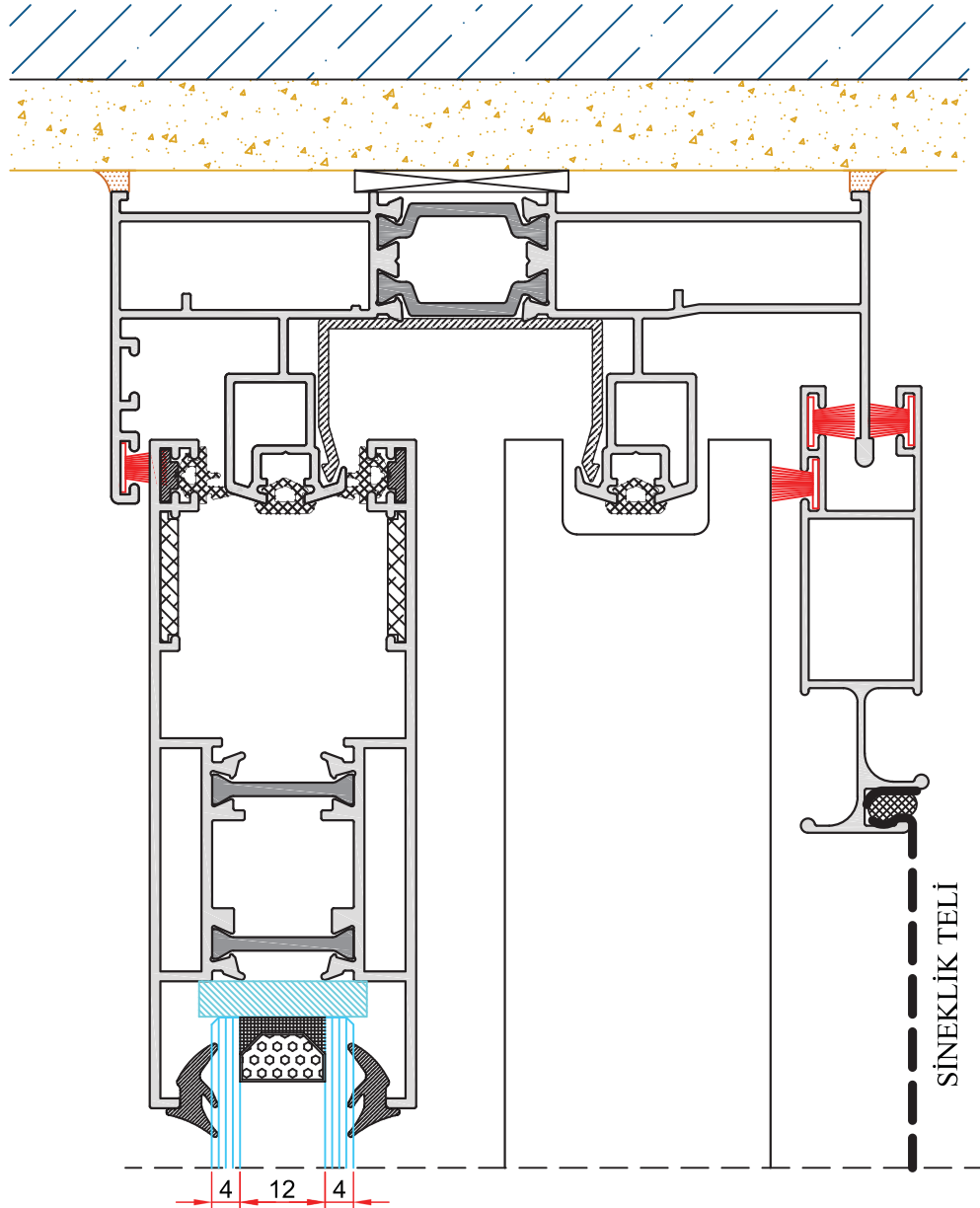

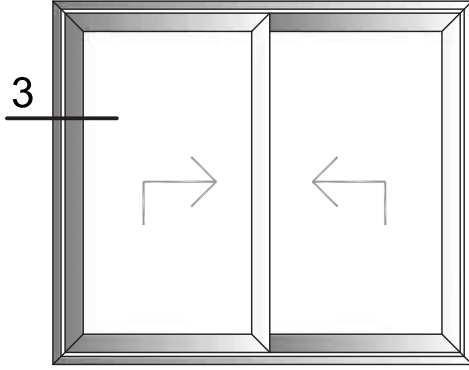

Yalıtımlı Dar Sürme Pencere

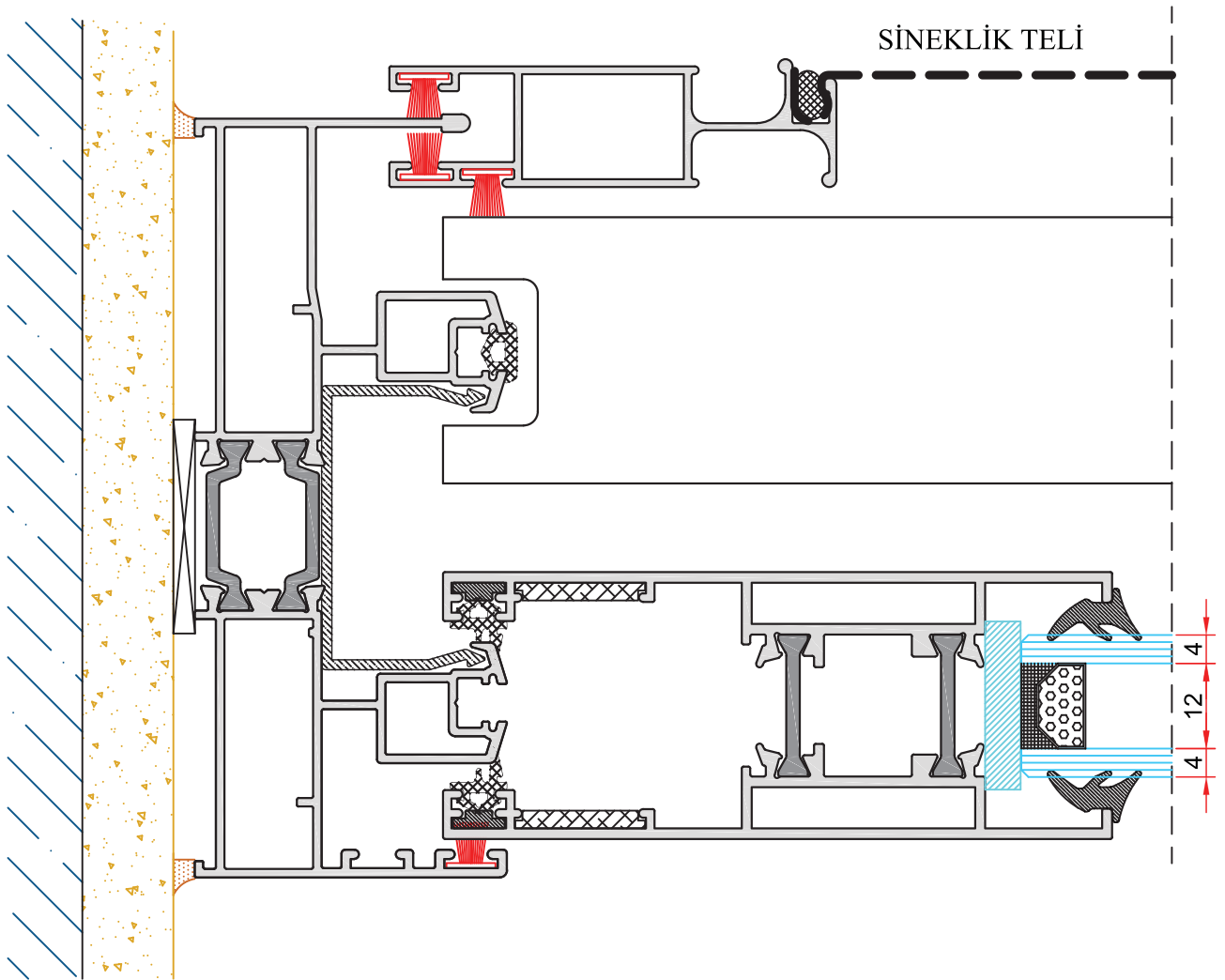

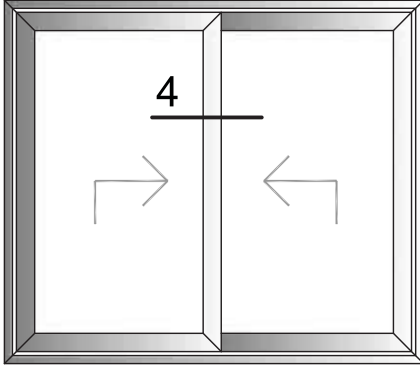

Yalıtımlı Dar Sürme Pencere

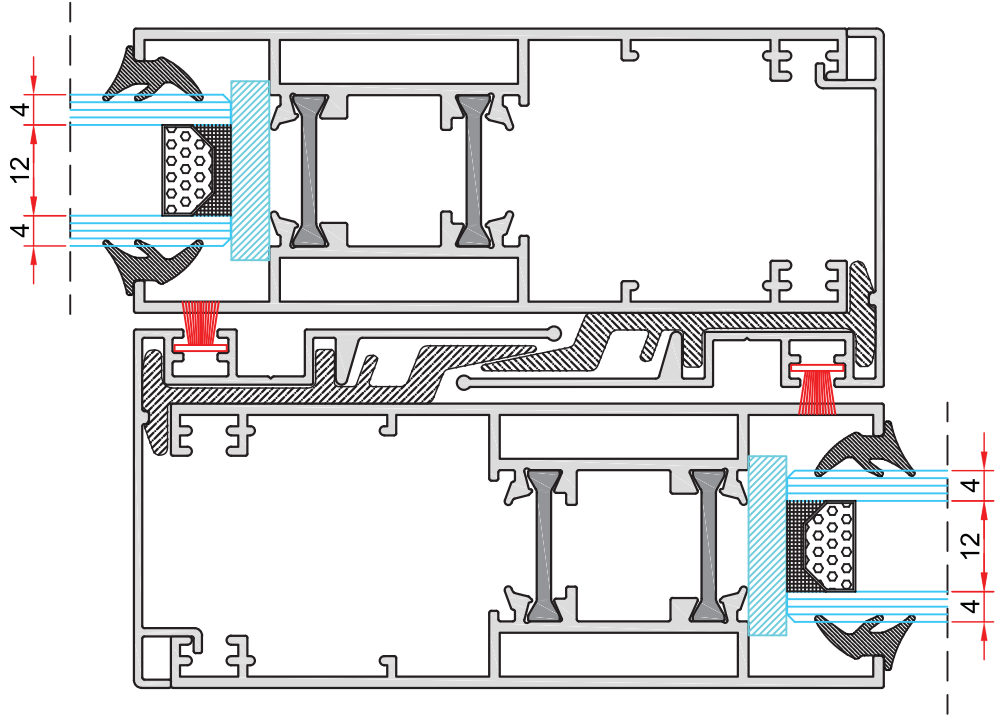



**KOD-CODE**      *TEORİK AĞIRLIK*  
*THEORETICAL WEIGHT*  
**KS-4511-13**    **2,435 Kg/m**

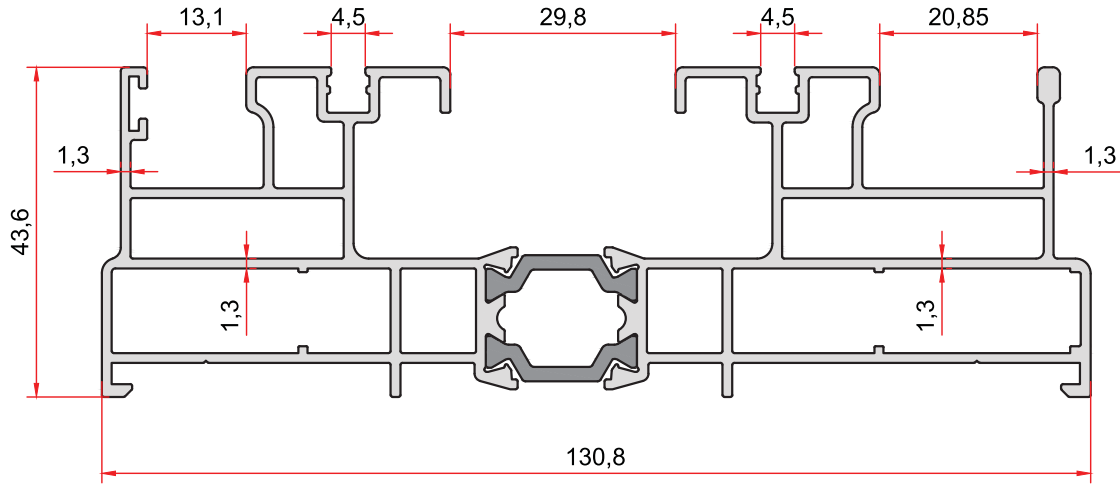

**KOD-CODE**      *TEORİK AĞIRLIK*  
*THEORETICAL WEIGHT*  
**KS-4512-13**    **2,044 Kg/m**

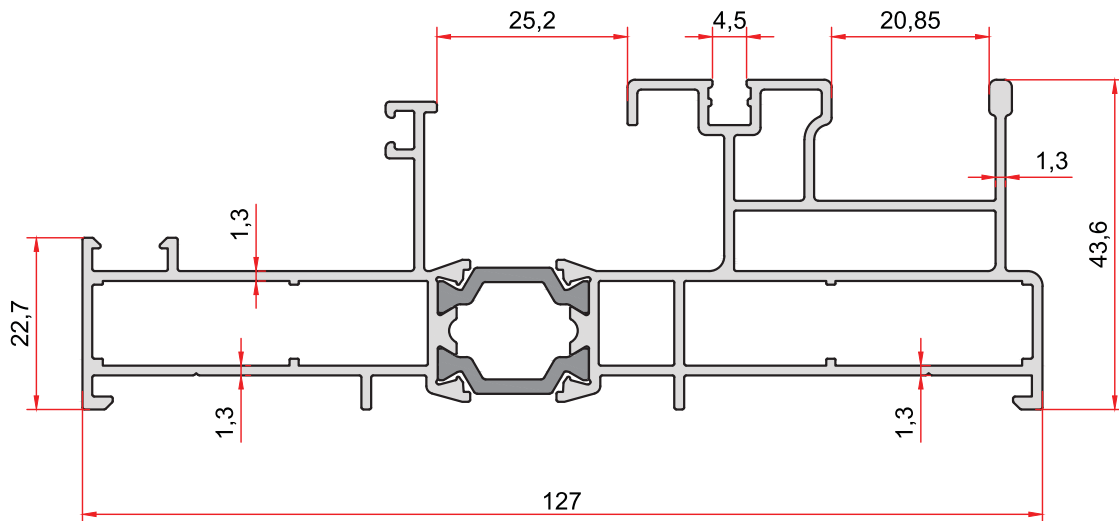

**KOD-CODE**      **TEORİK AĞIRLIK**  
**KS-4513-14**      **THEORETICAL WEIGHT**  
**1,844 Kg/m**

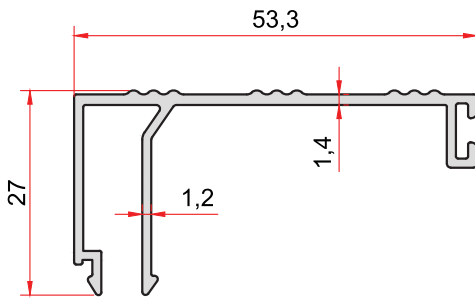
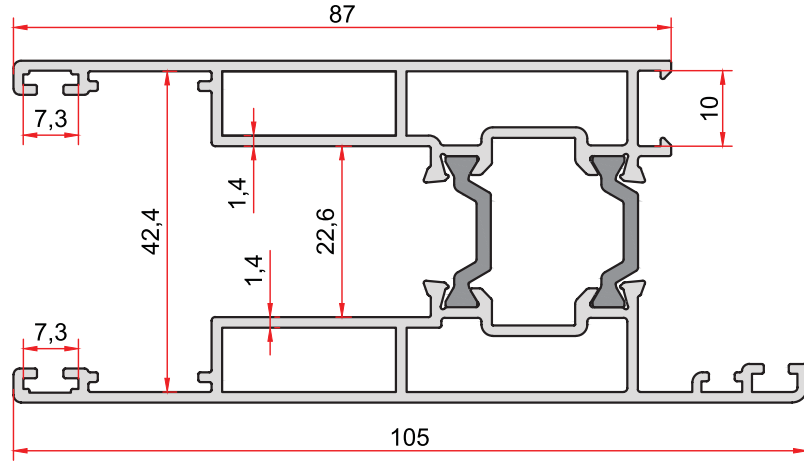

**KOD-CODE**      **TEORİK AĞIRLIK**  
**KS-4515-14**      **THEORETICAL WEIGHT**  
**0,443 Kg/m**

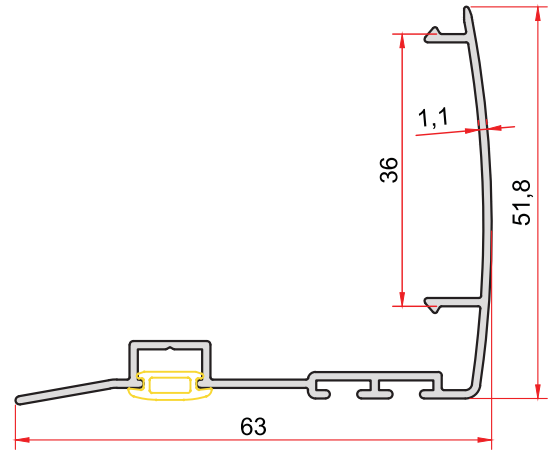

**KOD-CODE**      **TEORİK AĞIRLIK**  
**KS-4514-11**      **THEORETICAL WEIGHT**  
**0,448 Kg/m**

# Doğrama Profilleri

## Yalıtımlı Sürme Seri

**ARFEM**<sup>®</sup>  
ALÜMİNYUM

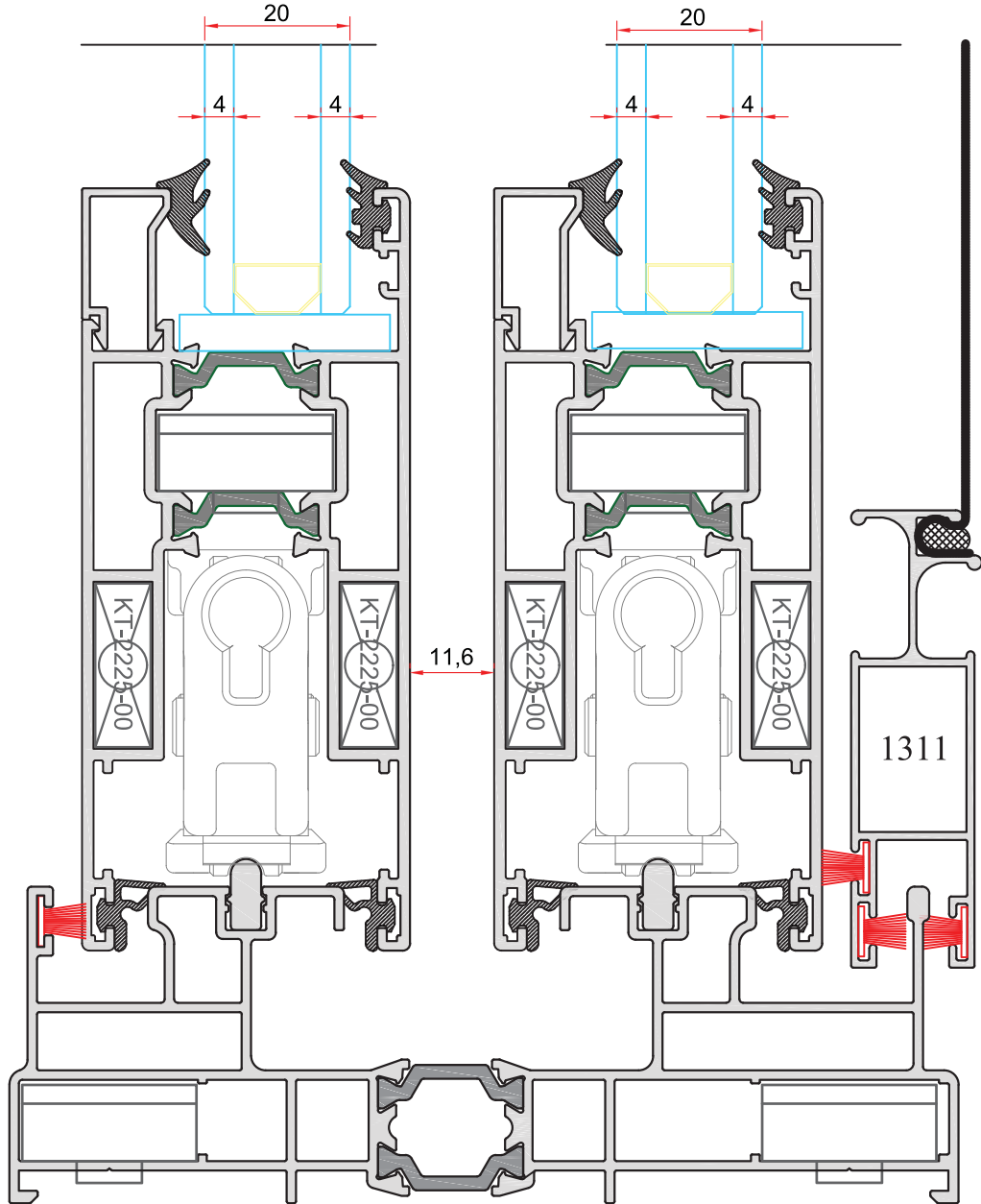
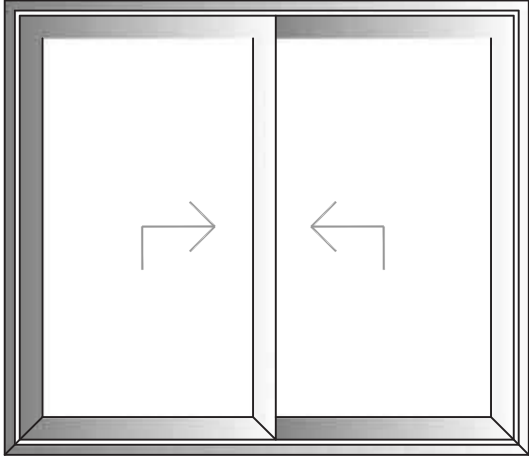

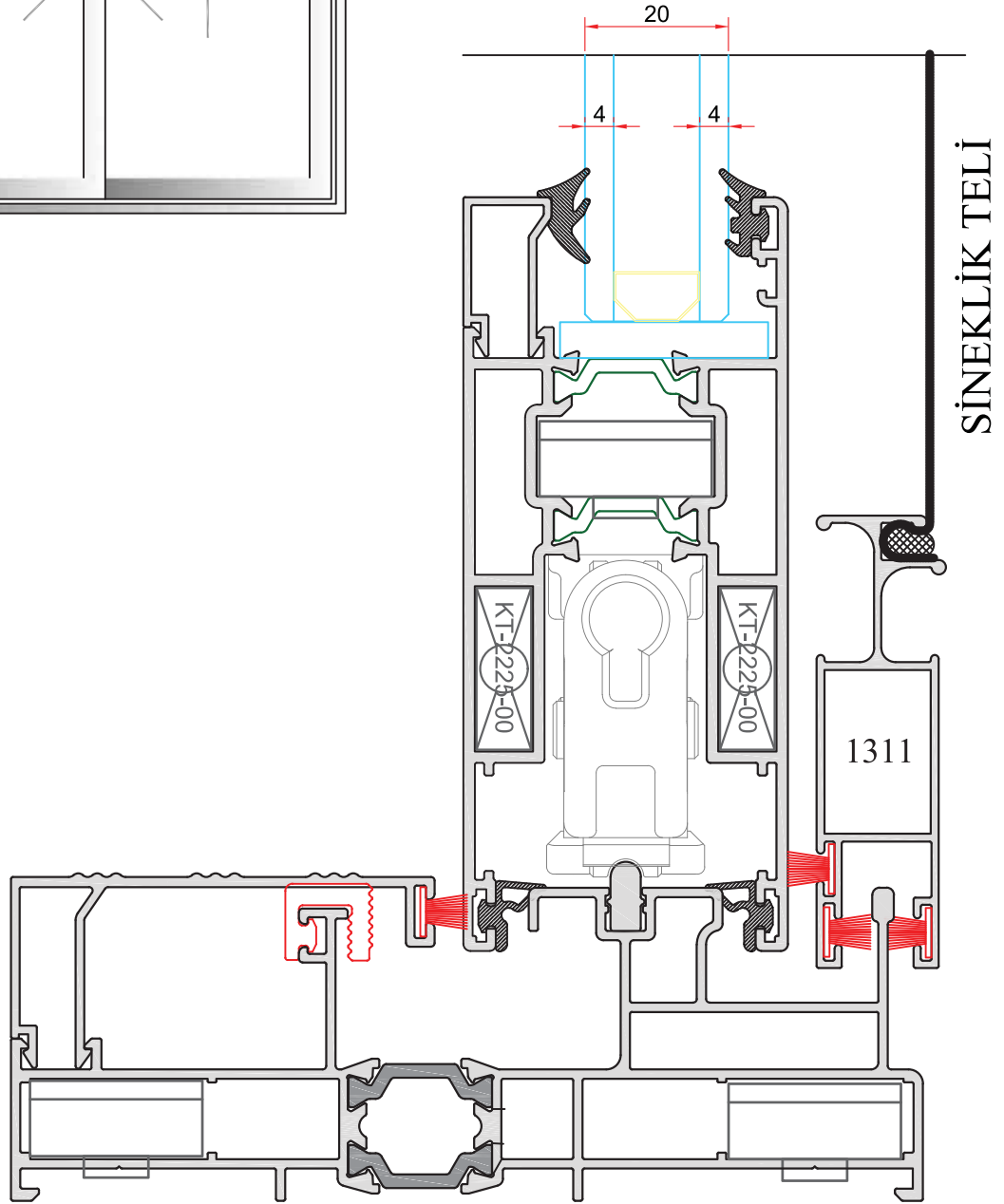
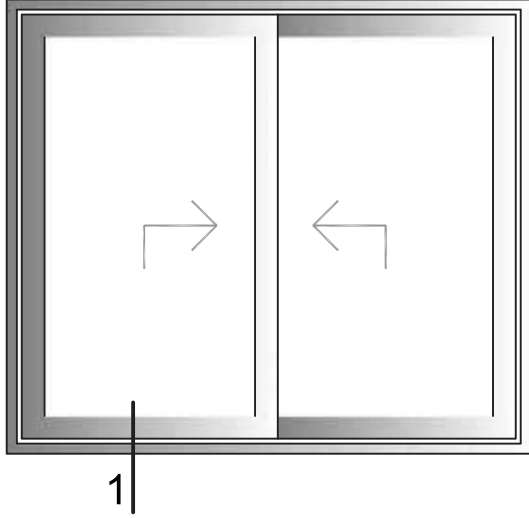

## Doğrama Profilleri Yalıtımlı Sürme Seri

**ARFEM**<sup>®</sup>  
ALÜMİNYUM

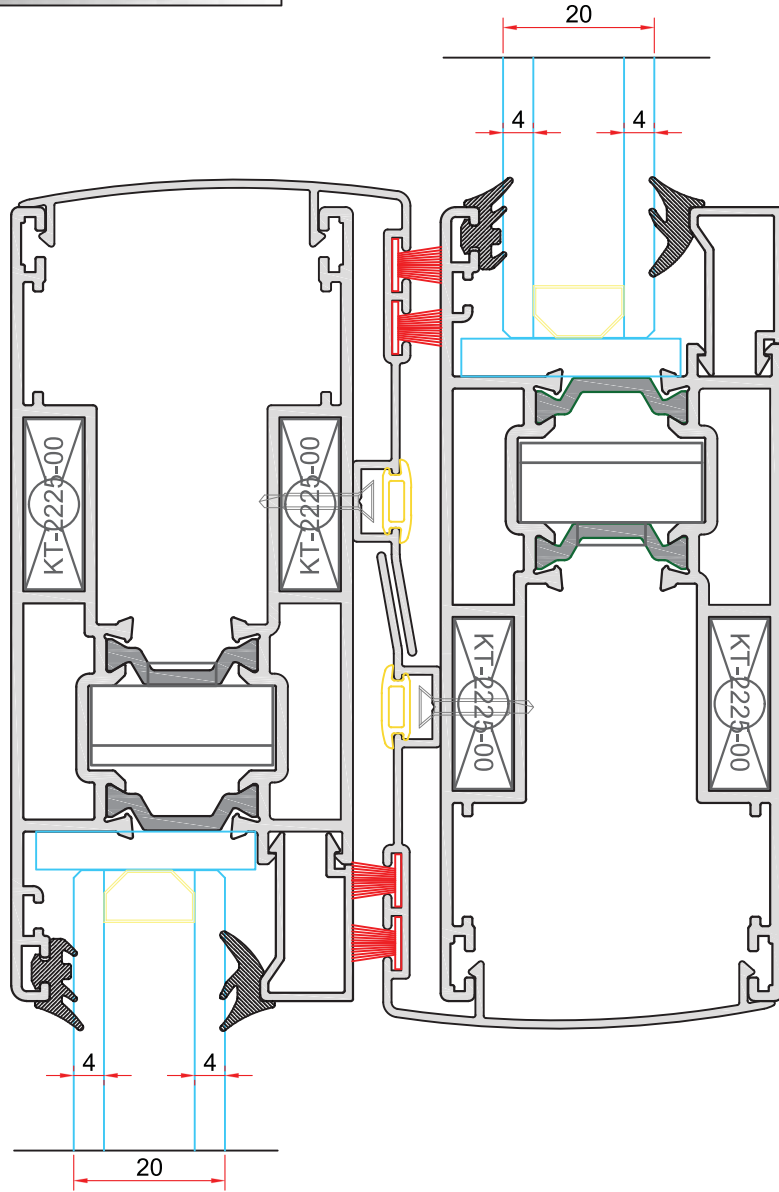
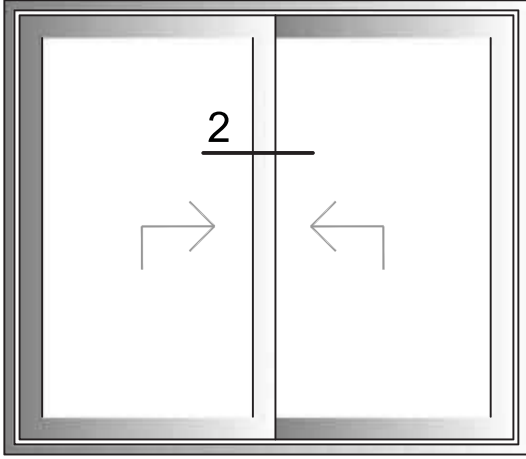

2

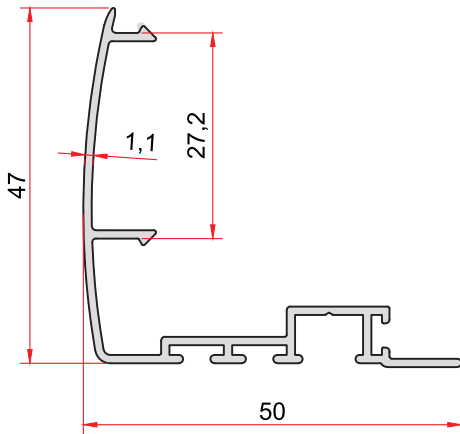

**KOD-CODE** *TEORİK AĞIRLIK*  
*THEORETICAL WEIGHT*  
**ASS-4513-11** **0,415 Kg/m**

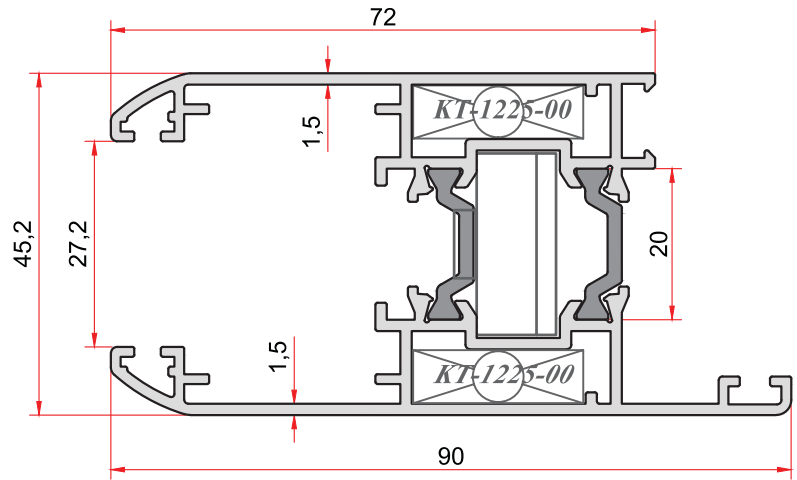

**KOD-CODE** *TEORİK AĞIRLIK*  
*THEORETICAL WEIGHT*  
**ASS-4512-15** **1,650 Kg/m**

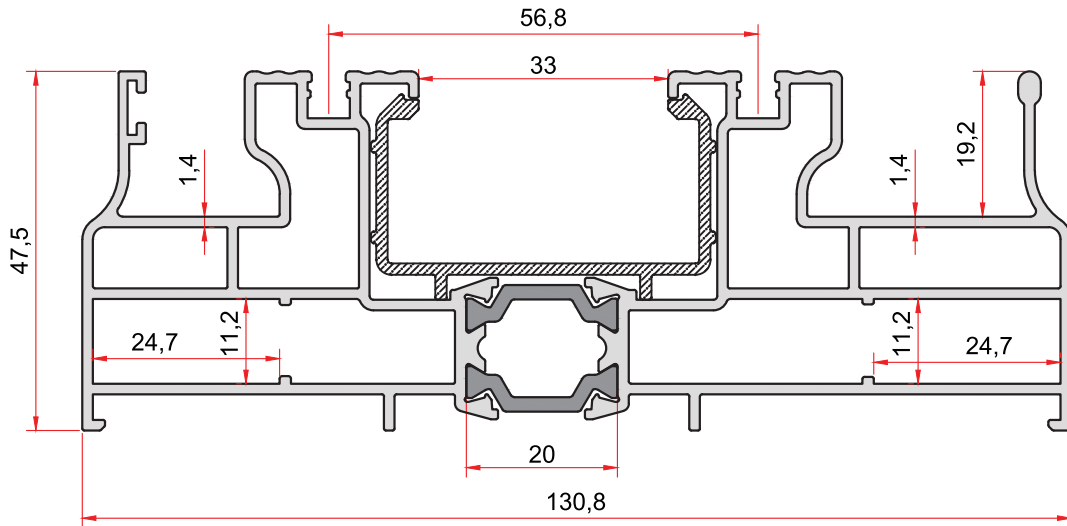

**KOD-CODE** *TEORİK AĞIRLIK*  
*THEORETICAL WEIGHT*  
**ASS-4511-14** **2,603 Kg/m**

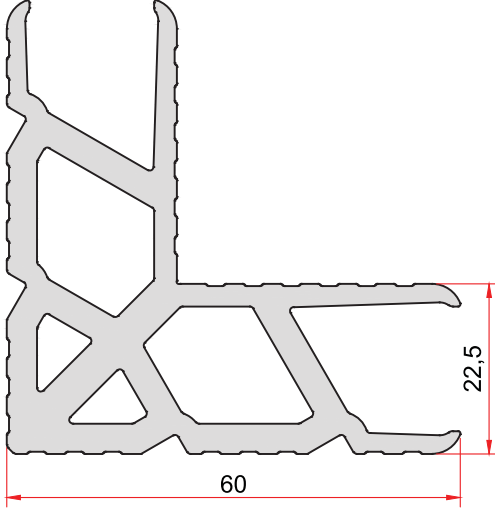

**KOD-CODE** TEORİK AĞIRLIK  
THEORETICAL WEIGHT  
**KT-2225-00** **2,543 Kg/m**

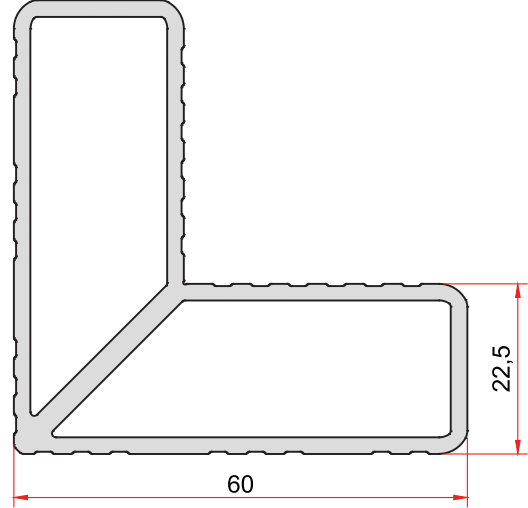

**KOD-CODE** TEORİK AĞIRLIK  
THEORETICAL WEIGHT  
**KT-225-00** **1,508 Kg/m**



**AC1-02** 2 mm Dış Cam Fitili  
1 Koli 12 Kg  
1 Koli 265 M



**AC2-01** 3 mm İç Cam Fitili  
1 Koli 15 Kg  
1 Koli 300 M



**AC2-02** 4 mm İç Cam Fitili  
1 Koli 10 Kg  
1 Koli 330 M



**AC2-03** 5 mm İç Cam Fitili  
1 Koli 15 Kg  
1 Koli 215 M



**AC3-01** Kasa-Kanat Bini Fitili  
1 Koli 10 Kg  
1 Koli 330 M



**AC5-04** 1 Koli 15 Kg  
1 Koli 218 M

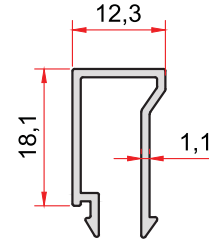

**KOD-CODE** TEORİK AĞIRLIK  
THEORETICAL WEIGHT  
**SS-302-11** **0,176 Kg/m**

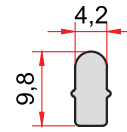

**KOD-CODE** TEORİK AĞIRLIK  
THEORETICAL WEIGHT  
**SS-507-00** **0,108 Kg/m**

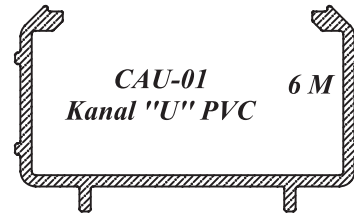

**CAU-01** 6 M  
Kanal "U" PVC

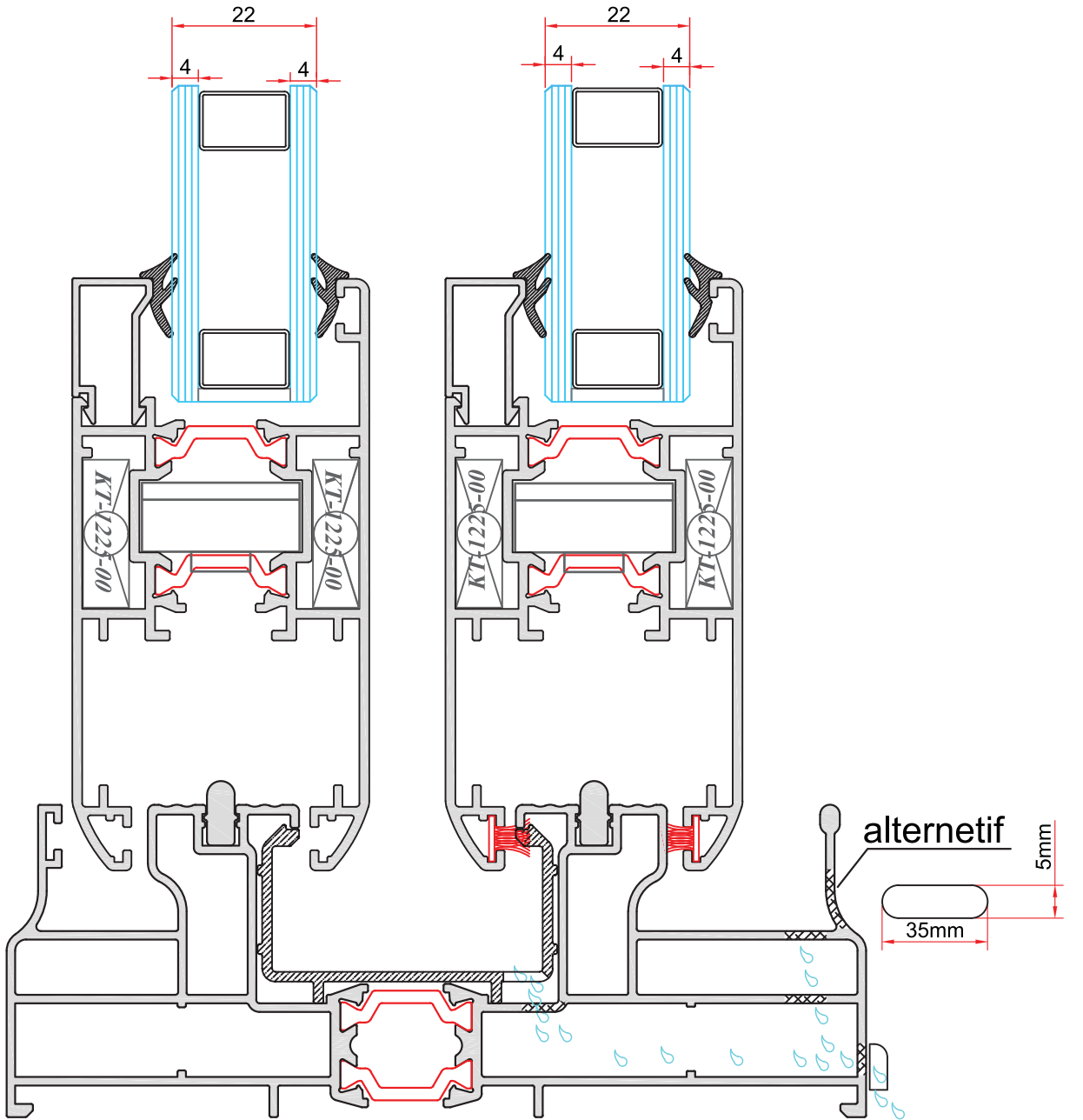
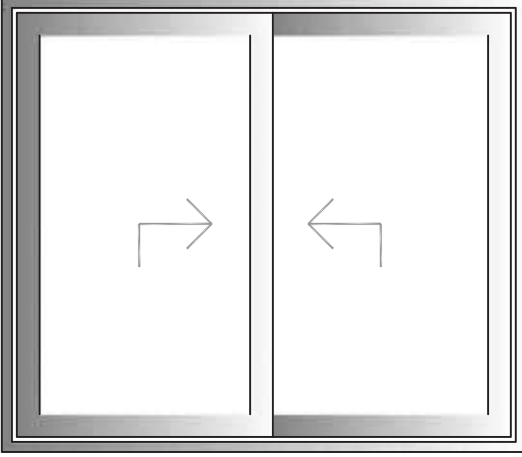



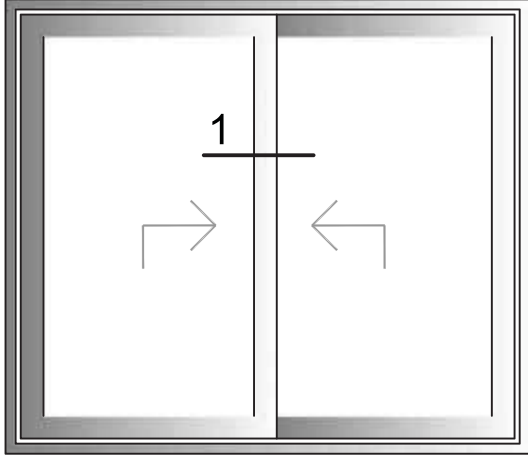

1

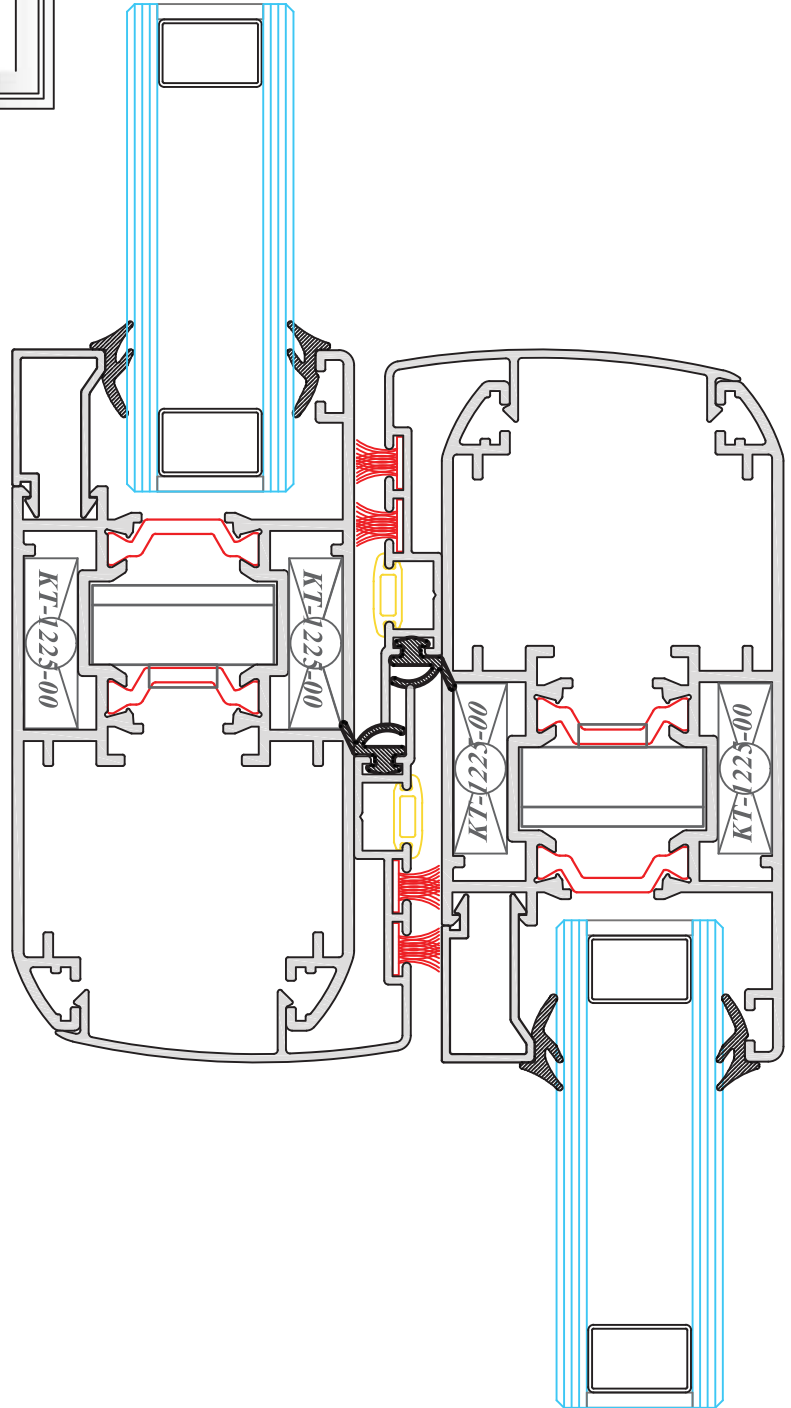

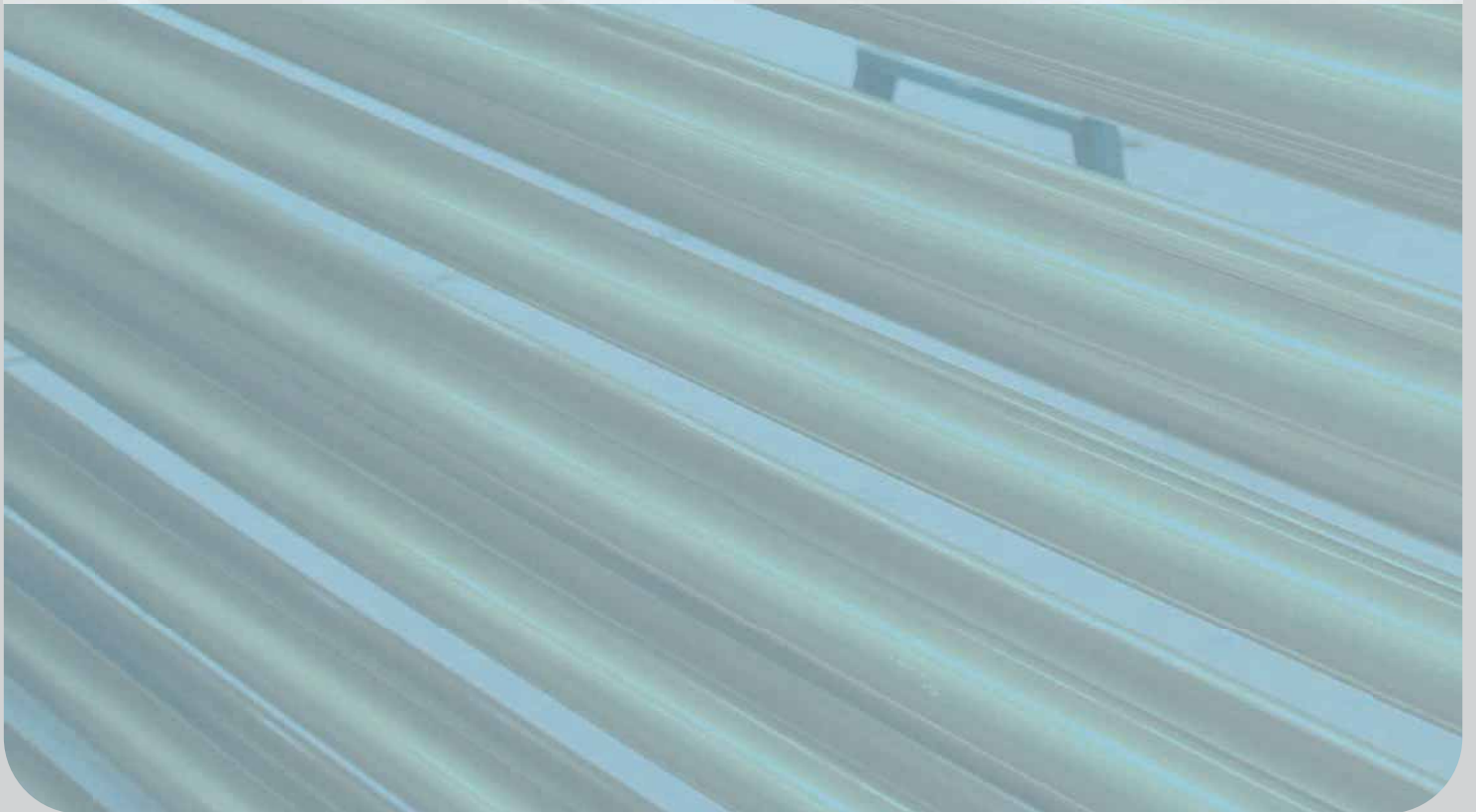
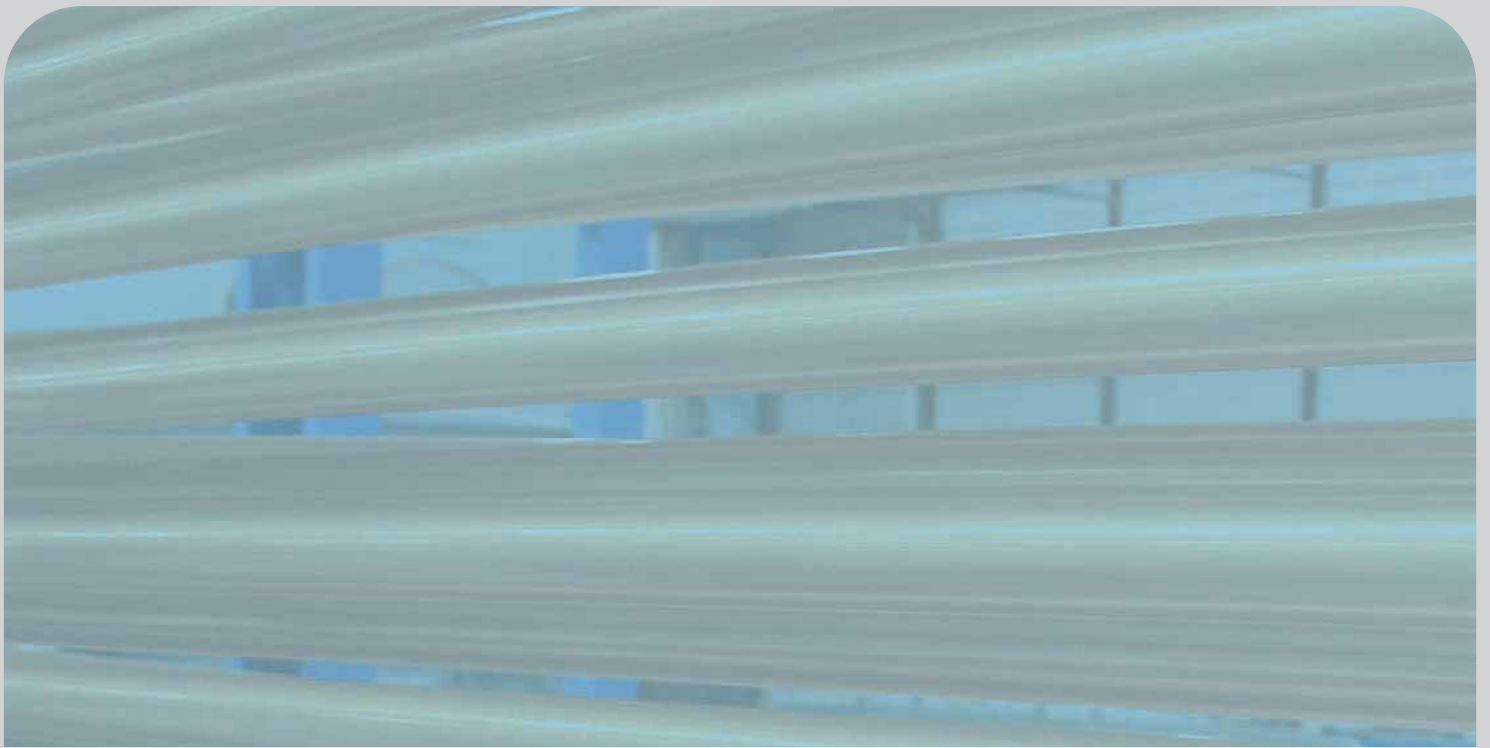

**ARFEM**<sup>®</sup>  
ALÜMİNYUM

**Sineklik Profilleri**

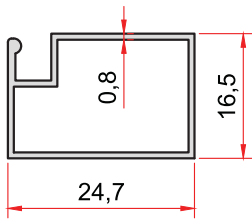

**KOD-CODE** *TEORİK AĞIRLIK*  
*THEORETICAL WEIGHT*  
**1301** **0,189 Kg/m**

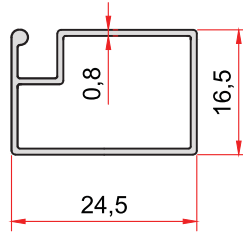

**KOD-CODE** *TEORİK AĞIRLIK*  
*THEORETICAL WEIGHT*  
**1302** **0,191 Kg/m**

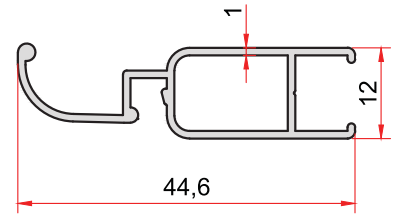

**KOD-CODE** *TEORİK AĞIRLIK*  
*THEORETICAL WEIGHT*  
**1303** **0,286 Kg/m**

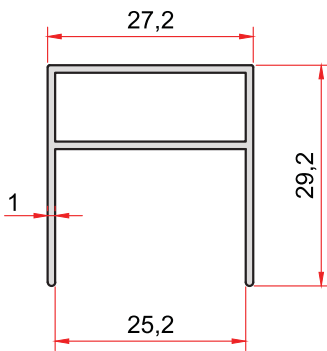

**KOD-CODE** *TEORİK AĞIRLIK*  
*THEORETICAL WEIGHT*  
**1304** **0,294 Kg/m**

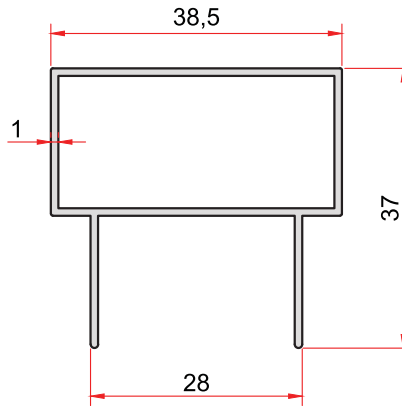

**KOD-CODE** *TEORİK AĞIRLIK*  
*THEORETICAL WEIGHT*  
**1305** **0,397 Kg/m**

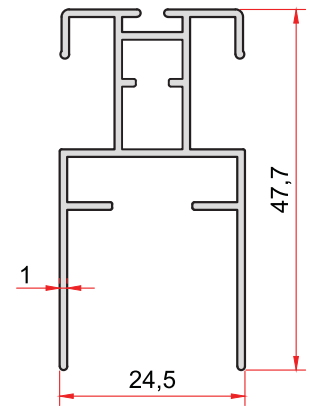

**KOD-CODE** *TEORİK AĞIRLIK*  
*THEORETICAL WEIGHT*  
**1306** **0,459 Kg/m**

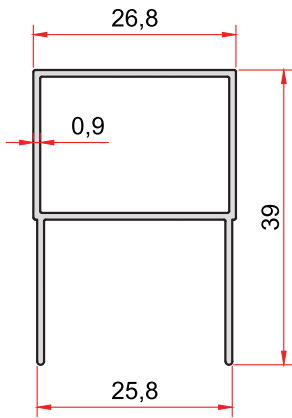

**KOD-CODE** *TEORİK AĞIRLIK*  
*THEORETICAL WEIGHT*  
**1307** **0,311 Kg/m**

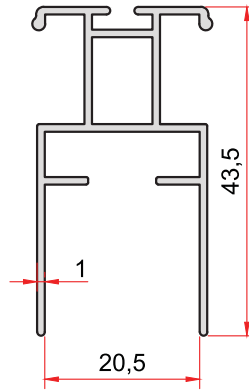

**KOD-CODE** *TEORİK AĞIRLIK*  
*THEORETICAL WEIGHT*  
**1308** **0,413 Kg/m**

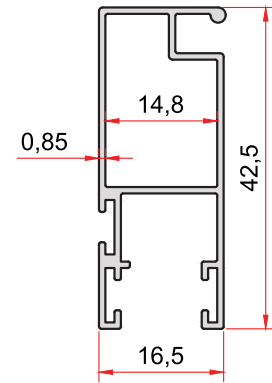

**KOD-CODE** *TEORİK AĞIRLIK*  
*THEORETICAL WEIGHT*  
**1310** **0,335 Kg/m**

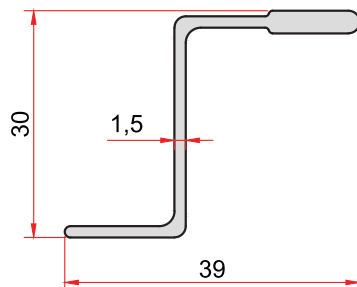

**KOD-CODE** *TEORİK AĞIRLIK*  
*THEORETICAL WEIGHT*  
**1309** **0,319 Kg/m**



# ARFEM<sup>®</sup>

## ALÜMİNYUM

### Mobilya Profilleri





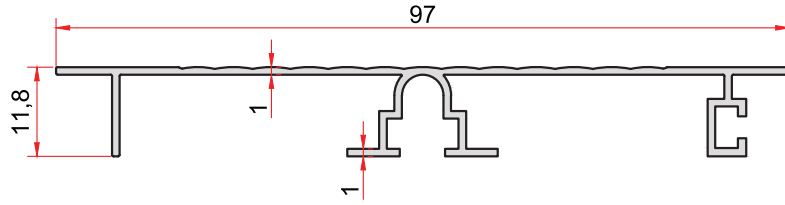

**KOD-CODE** *TEORİK AĞIRLIK*  
*THEORETICAL WEIGHT*  
1441 0,443 Kg/m

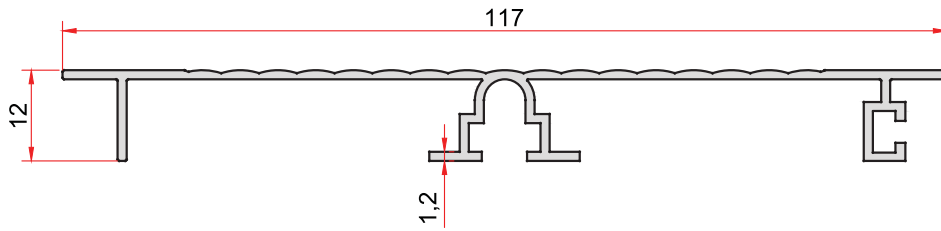

**KOD-CODE** *TEORİK AĞIRLIK*  
*THEORETICAL WEIGHT*  
1352 0,580 Kg/m

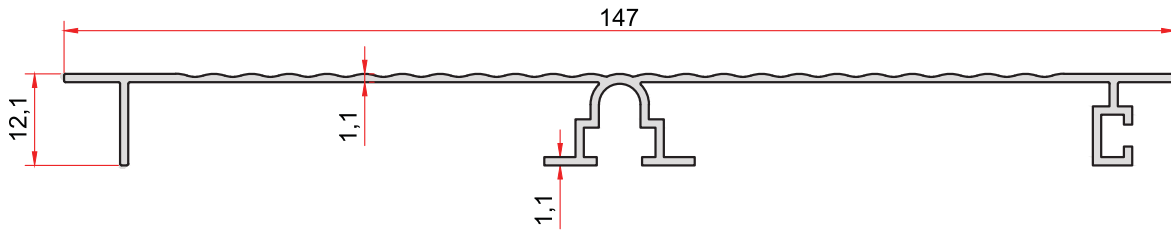

**KOD-CODE** *TEORİK AĞIRLIK*  
*THEORETICAL WEIGHT*  
1353 0,588 Kg/m

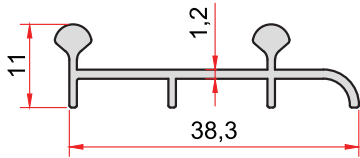

**KOD-CODE** *TEORİK AĞIRLIK*  
*THEORETICAL WEIGHT*  
1402 0,246 Kg/m

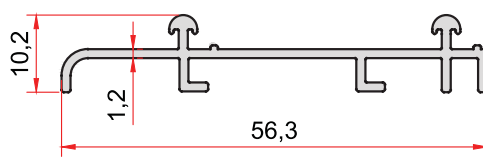

**KOD-CODE** *TEORİK AĞIRLIK*  
*THEORETICAL WEIGHT*  
1364 0,321 Kg/m

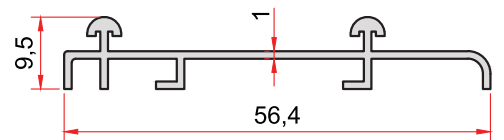

**KOD-CODE** *TEORİK AĞIRLIK*  
*THEORETICAL WEIGHT*  
1376 0,275 Kg/m

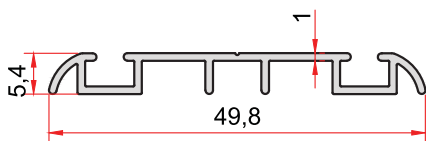

**KOD-CODE** *TEORİK AĞIRLIK*  
*THEORETICAL WEIGHT*  
1456 0,230 Kg/m

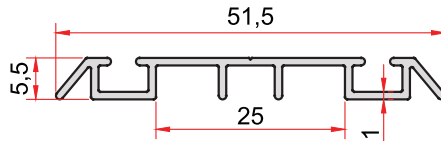

**KOD-CODE** *TEORİK AĞIRLIK*  
*THEORETICAL WEIGHT*  
1359 0,240 Kg/m

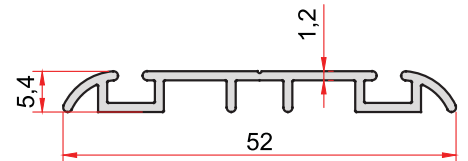

**KOD-CODE** *TEORİK AĞIRLIK*  
*THEORETICAL WEIGHT*  
1372 0,275 Kg/m

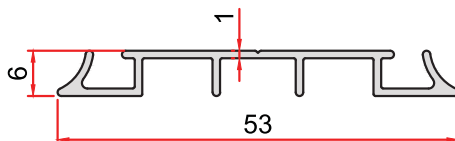

**KOD-CODE** *TEORİK AĞIRLIK*  
*THEORETICAL WEIGHT*  
1501 0,240 Kg/m

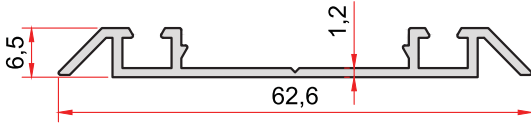

**KOD-CODE** *TEORİK AĞIRLIK*  
*THEORETICAL WEIGHT*  
**1423** **0,313 Kg/m**

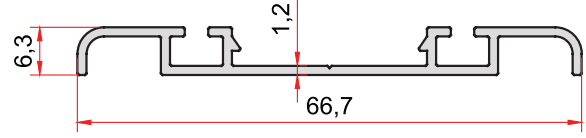

**KOD-CODE** *TEORİK AĞIRLIK*  
*THEORETICAL WEIGHT*  
**1355** **0,337 Kg/m**

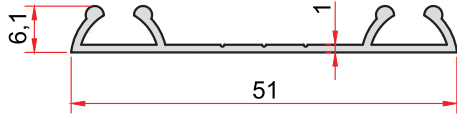

**KOD-CODE** *TEORİK AĞIRLIK*  
*THEORETICAL WEIGHT*  
**1422** **0,220 Kg/m**

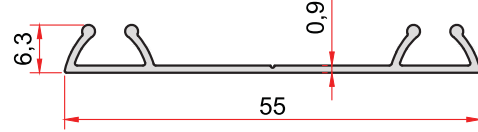

**KOD-CODE** *TEORİK AĞIRLIK*  
*THEORETICAL WEIGHT*  
**1373** **0,211 Kg/m**

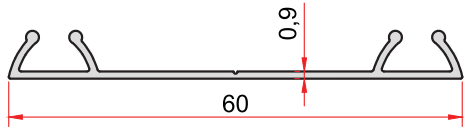

**KOD-CODE** *TEORİK AĞIRLIK*  
*THEORETICAL WEIGHT*  
**1450** **0,224 Kg/m**

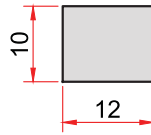

**KOD-CODE** *TEORİK AĞIRLIK*  
*THEORETICAL WEIGHT*  
**1413** **0,324 Kg/m**

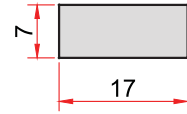

**KOD-CODE** *TEORİK AĞIRLIK*  
*THEORETICAL WEIGHT*  
**1411** **0,321 Kg/m**

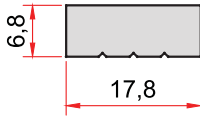

**KOD-CODE** *TEORİK AĞIRLIK*  
*THEORETICAL WEIGHT*  
**1415** **0,324 Kg/m**

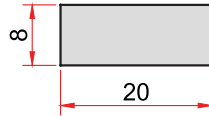

**KOD-CODE** *TEORİK AĞIRLIK*  
*THEORETICAL WEIGHT*  
**1412** **0,432 Kg/m**

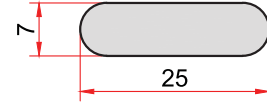

**KOD-CODE** *TEORİK AĞIRLIK*  
*THEORETICAL WEIGHT*  
**1408** **0,443 Kg/m**

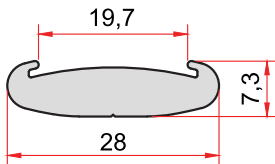

**KOD-CODE** *TEORİK AĞIRLIK*  
*THEORETICAL WEIGHT*  
**1454** **0,429 Kg/m**

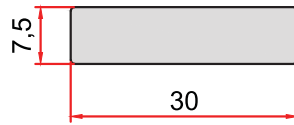

**KOD-CODE** *TEORİK AĞIRLIK*  
*THEORETICAL WEIGHT*  
**1407** **0,607 Kg/m**

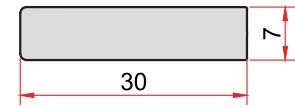

**KOD-CODE** *TEORİK AĞIRLIK*  
*THEORETICAL WEIGHT*  
**1483** **0,564 Kg/m**

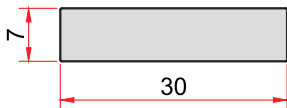

**KOD-CODE** *TEORİK AĞIRLIK*  
*THEORETICAL WEIGHT*  
**1492** **0,567 Kg/m**

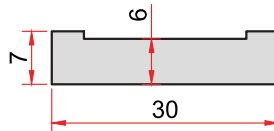

**KOD-CODE** *TEORİK AĞIRLIK*  
*THEORETICAL WEIGHT*  
**1428** **0,510 Kg/m**

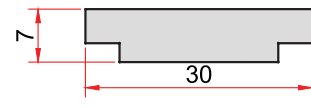

**KOD-CODE** *TEORİK AĞIRLIK*  
*THEORETICAL WEIGHT*  
**1420** **0,518 Kg/m**

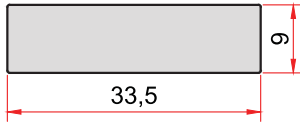

**KOD-CODE** *TEORİK AĞIRLIK*  
*THEORETICAL WEIGHT*  
**1455** **0,812 Kg/m**

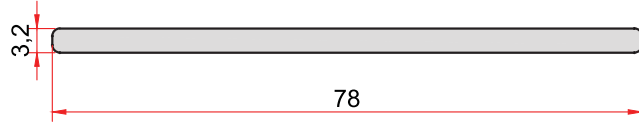

**KOD-CODE** *TEORİK AĞIRLIK*  
*THEORETICAL WEIGHT*  
**1418** **0,672 Kg/m**

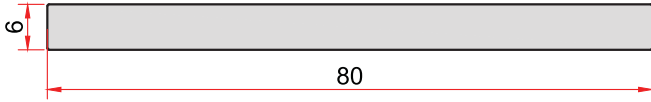

**KOD-CODE** *TEORİK AĞIRLIK*  
*THEORETICAL WEIGHT*  
**1495** **1,296 Kg/m**

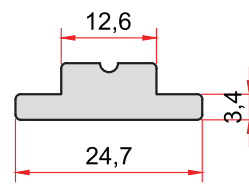

**KOD-CODE** *TEORİK AĞIRLIK*  
*THEORETICAL WEIGHT*  
**1440** **0,356 Kg/m**

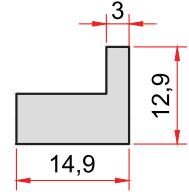

**KOD-CODE** *TEORİK AĞIRLIK*  
*THEORETICAL WEIGHT*  
**1409** **0,319 Kg/m**

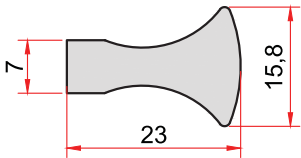

**KOD-CODE** *TEORİK AĞIRLIK*  
*THEORETICAL WEIGHT*  
**1439** **0,489 Kg/m**

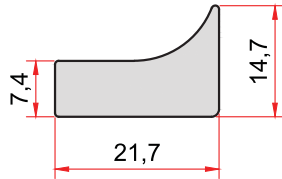

**KOD-CODE** *TEORİK AĞIRLIK*  
*THEORETICAL WEIGHT*  
**1497** **0,505 Kg/m**

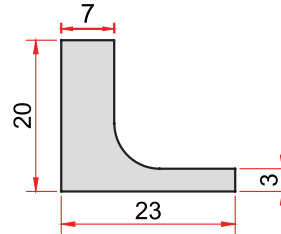

**KOD-CODE** *TEORİK AĞIRLIK*  
*THEORETICAL WEIGHT*  
**1414** **0,529 Kg/m**

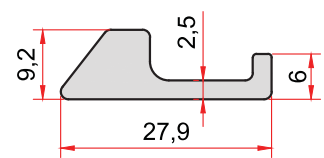

**KOD-CODE** *TEORİK AĞIRLIK*  
*THEORETICAL WEIGHT*  
**1490** **0,362 Kg/m**

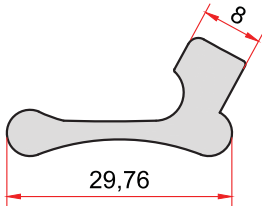

**KOD-CODE** *TEORİK AĞIRLIK*  
*THEORETICAL WEIGHT*  
**1475** **0,480 Kg/m**

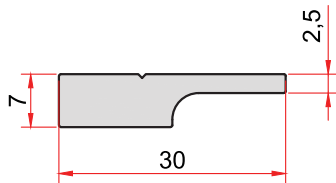

**KOD-CODE** *TEORİK AĞIRLIK*  
*THEORETICAL WEIGHT*  
**1476** **0,392 Kg/m**

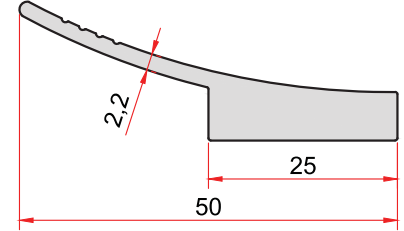

**KOD-CODE** *TEORİK AĞIRLIK*  
*THEORETICAL WEIGHT*  
**1471** **0,645 Kg/m**

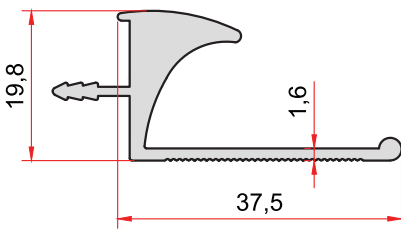

**KOD-CODE** *TEORİK AĞIRLIK*  
*THEORETICAL WEIGHT*  
**1383** **0,500 Kg/m**

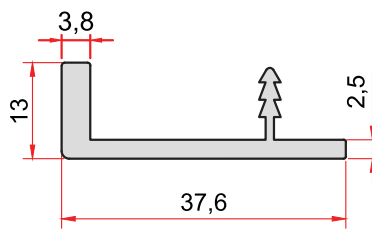

**KOD-CODE** *TEORİK AĞIRLIK*  
*THEORETICAL WEIGHT*  
**1406** **0,399 Kg/m**

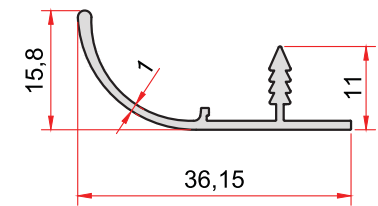

**KOD-CODE** *TEORİK AĞIRLIK*  
*THEORETICAL WEIGHT*  
**1484** **0,211 Kg/m**

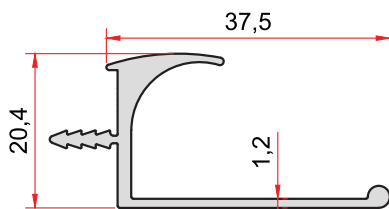

**KOD-CODE** *TEORİK AĞIRLIK*  
*THEORETICAL WEIGHT*  
**1498** **0,377 Kg/m**

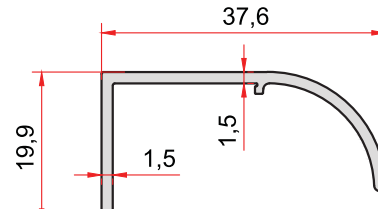

**KOD-CODE** *TEORİK AĞIRLIK*  
*THEORETICAL WEIGHT*  
**1508** **0,262 Kg/m**



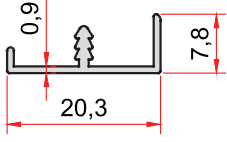

**KOD-CODE** *TEORİK AĞIRLIK*  
*THEORETICAL WEIGHT*  
1356 0,097 Kg/m

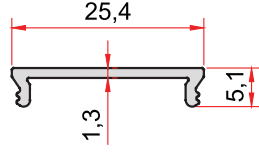

**KOD-CODE** *TEORİK AĞIRLIK*  
*THEORETICAL WEIGHT*  
1354 0,121 Kg/m

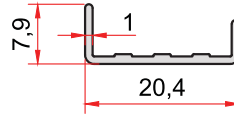

**KOD-CODE** *TEORİK AĞIRLIK*  
*THEORETICAL WEIGHT*  
1506 0,090 Kg/m

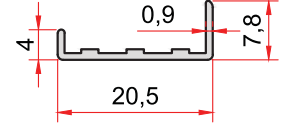

**KOD-CODE** *TEORİK AĞIRLIK*  
*THEORETICAL WEIGHT*  
1392 0,081 Kg/m

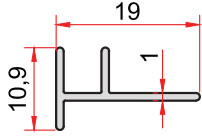

**KOD-CODE** *TEORİK AĞIRLIK*  
*THEORETICAL WEIGHT*  
1503 0,091 Kg/m

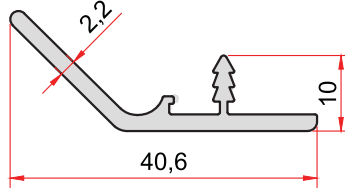

**KOD-CODE** *TEORİK AĞIRLIK*  
*THEORETICAL WEIGHT*  
1474 0,324 Kg/m

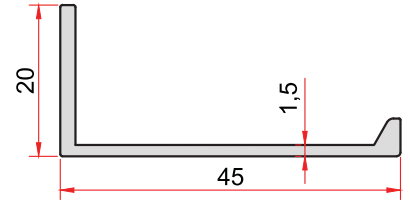

**KOD-CODE** *TEORİK AĞIRLIK*  
*THEORETICAL WEIGHT*  
1487 0,308 Kg/m

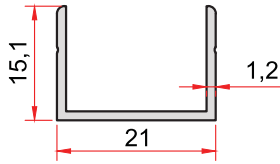

**KOD-CODE** *TEORİK AĞIRLIK*  
*THEORETICAL WEIGHT*  
1481 0,156 Kg/m

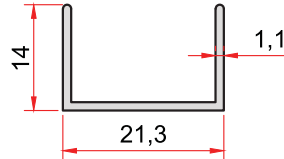

**KOD-CODE** *TEORİK AĞIRLIK*  
*THEORETICAL WEIGHT*  
1388 0,140 Kg/m

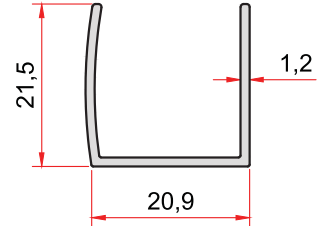

**KOD-CODE** *TEORİK AĞIRLIK*  
*THEORETICAL WEIGHT*  
1379 0,200 Kg/m

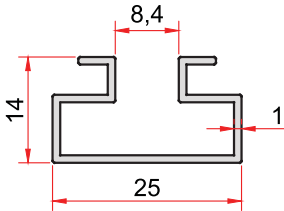

**KOD-CODE** *TEORİK AĞIRLIK*  
*THEORETICAL WEIGHT*  
1391 0,197 Kg/m

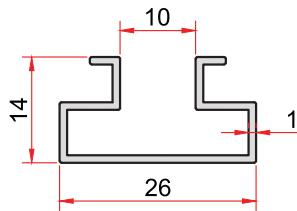

**KOD-CODE** *TEORİK AĞIRLIK*  
*THEORETICAL WEIGHT*  
1451 0,194 Kg/m

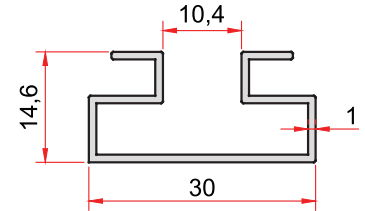

**KOD-CODE** *TEORİK AĞIRLIK*  
*THEORETICAL WEIGHT*  
1389 0,232 Kg/m

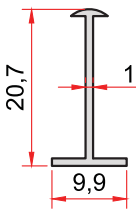

**KOD-CODE** *TEORİK AĞIRLIK*  
*THEORETICAL WEIGHT*  
1432 0,086 Kg/m

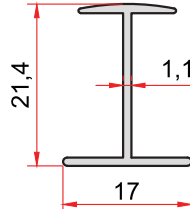

**KOD-CODE** *TEORİK AĞIRLIK*  
*THEORETICAL WEIGHT*  
1385 0,140 Kg/m

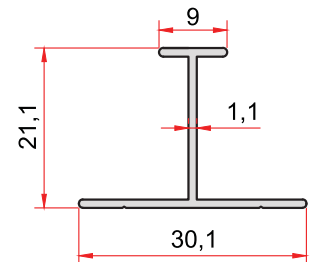

**KOD-CODE** *TEORİK AĞIRLIK*  
*THEORETICAL WEIGHT*  
1378 0,173 Kg/m

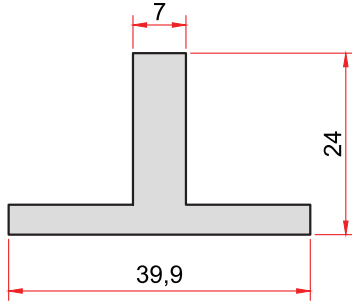

**KOD-CODE** TEORİK AĞIRLIK  
1416 0,805 Kg/m  
THEORETICAL WEIGHT

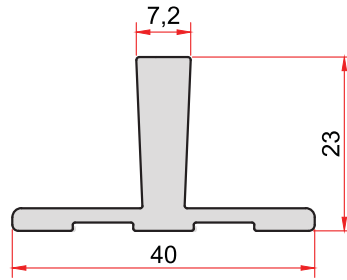

**KOD-CODE** TEORİK AĞIRLIK  
1473 0,618 Kg/m  
THEORETICAL WEIGHT

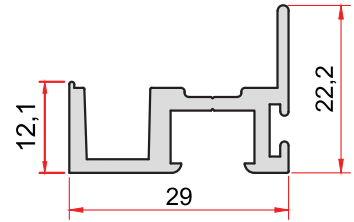

**KOD-CODE** TEORİK AĞIRLIK  
1367 0,408 Kg/m  
THEORETICAL WEIGHT

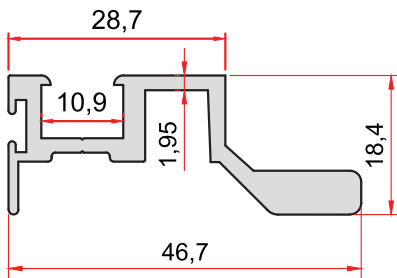

**KOD-CODE** TEORİK AĞIRLIK  
1368 0,637 Kg/m  
THEORETICAL WEIGHT

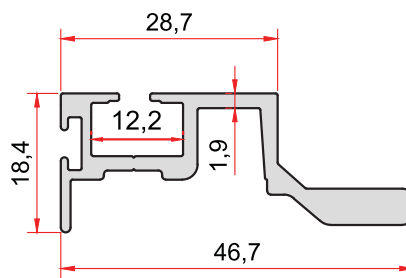

**KOD-CODE** TEORİK AĞIRLIK  
1467 0,581 Kg/m  
THEORETICAL WEIGHT

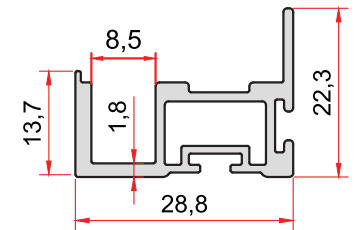

**KOD-CODE** TEORİK AĞIRLIK  
1470 0,397 Kg/m  
THEORETICAL WEIGHT

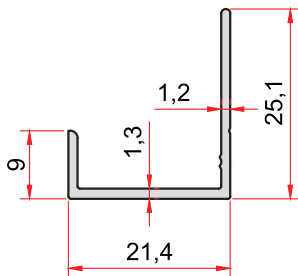

**KOD-CODE** TEORİK AĞIRLIK  
1377 0,178 Kg/m  
THEORETICAL WEIGHT

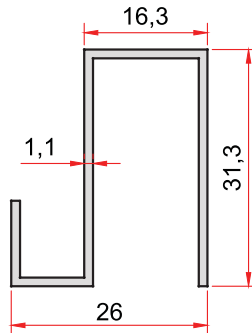

**KOD-CODE** TEORİK AĞIRLIK  
1366 0,300 Kg/m  
THEORETICAL WEIGHT

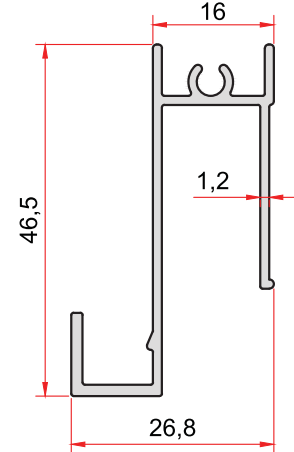

**KOD-CODE** TEORİK AĞIRLIK  
1469 0,413 Kg/m  
THEORETICAL WEIGHT

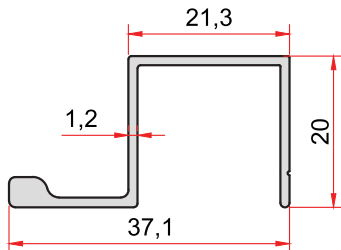

**KOD-CODE** TEORİK AĞIRLIK  
1374 0,281 Kg/m  
THEORETICAL WEIGHT

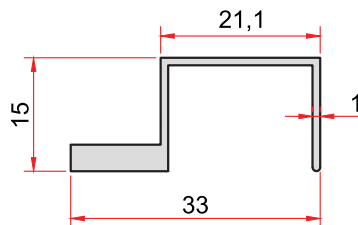

**KOD-CODE** TEORİK AĞIRLIK  
1386 0,246 Kg/m  
THEORETICAL WEIGHT

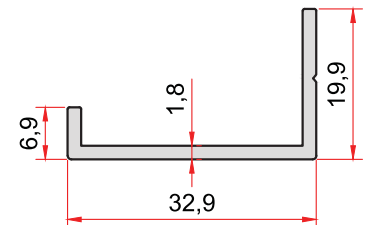

**KOD-CODE** TEORİK AĞIRLIK  
1446 0,273 Kg/m  
THEORETICAL WEIGHT

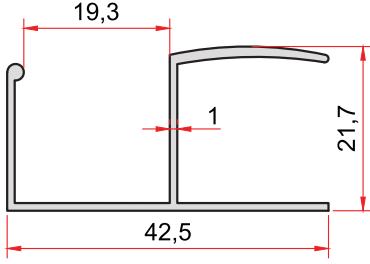

**KOD-CODE** *TEORİK AĞIRLIK*  
**1387** *THEORETICAL WEIGHT*  
**0,294 Kg/m**

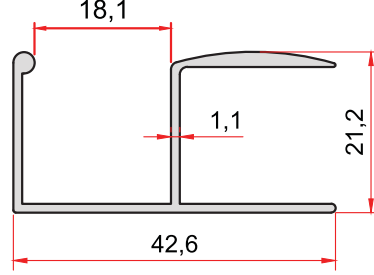

**KOD-CODE** *TEORİK AĞIRLIK*  
**1403** *THEORETICAL WEIGHT*  
**0,346 Kg/m**

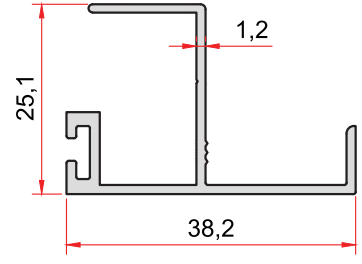

**KOD-CODE** *TEORİK AĞIRLIK*  
**1404** *THEORETICAL WEIGHT*  
**0,338 Kg/m**

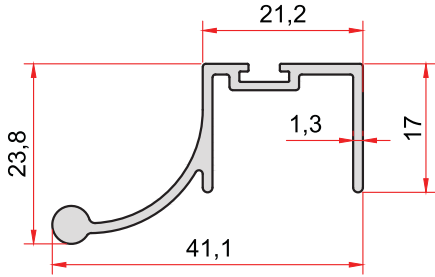

**KOD-CODE** *TEORİK AĞIRLIK*  
**1405** *THEORETICAL WEIGHT*  
**0,329 Kg/m**

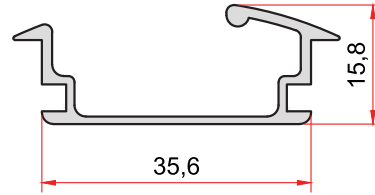

**KOD-CODE** *TEORİK AĞIRLIK*  
**1425** *THEORETICAL WEIGHT*  
**0,281 Kg/m**

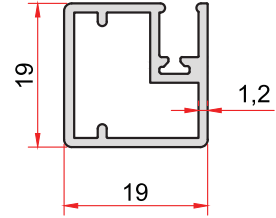

**KOD-CODE** *TEORİK AĞIRLIK*  
**1426** *THEORETICAL WEIGHT*  
**0,294 Kg/m**

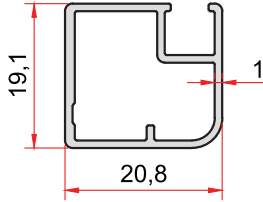

**KOD-CODE** *TEORİK AĞIRLIK*  
**1463** *THEORETICAL WEIGHT*  
**0,238 Kg/m**

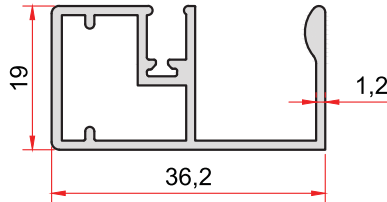

**KOD-CODE** *TEORİK AĞIRLIK*  
**1427** *THEORETICAL WEIGHT*  
**0,427 Kg/m**

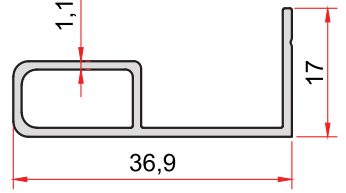

**KOD-CODE** *TEORİK AĞIRLIK*  
**1430** *THEORETICAL WEIGHT*  
**0,267 Kg/m**

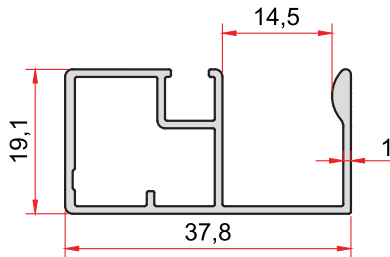

**KOD-CODE** *TEORİK AĞIRLIK*  
**1464** *THEORETICAL WEIGHT*  
**0,356 Kg/m**

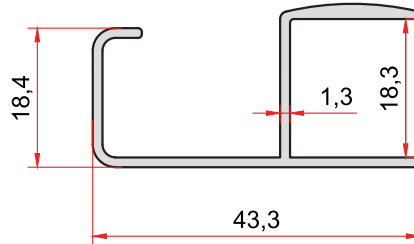

**KOD-CODE** *TEORİK AĞIRLIK*  
**1507** *THEORETICAL WEIGHT*  
**0,367 Kg/m**

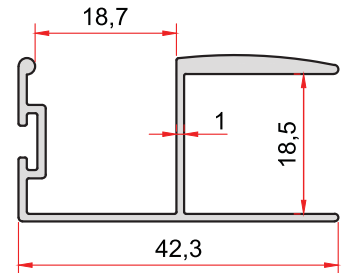

**KOD-CODE** *TEORİK AĞIRLIK*  
**1466** *THEORETICAL WEIGHT*  
**0,378 Kg/m**

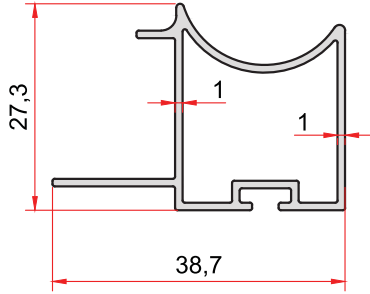

**KOD-CODE** *TEORİK AĞIRLIK*  
**1510** *THEORETICAL WEIGHT*  
**0,345 Kg/m**

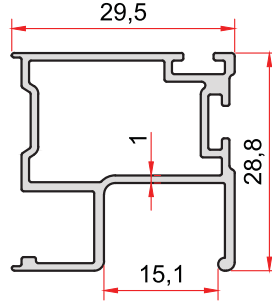

**KOD-CODE** *TEORİK AĞIRLIK*  
**1465** *THEORETICAL WEIGHT*  
**0,405 Kg/m**

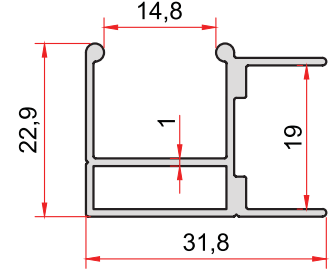

**KOD-CODE** *TEORİK AĞIRLIK*  
**1505** *THEORETICAL WEIGHT*  
**0,335 Kg/m**

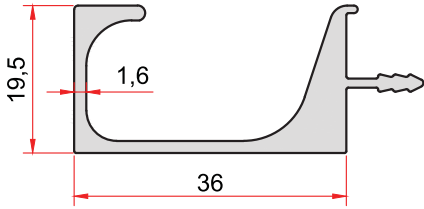

**KOD-CODE** *TEORİK AĞIRLIK*  
**1486** *THEORETICAL WEIGHT*  
**0,583 Kg/m**

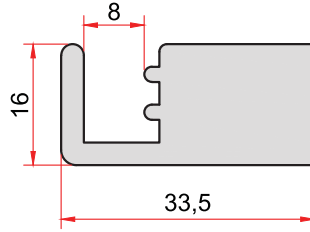

**KOD-CODE** *TEORİK AĞIRLIK*  
**1488** *THEORETICAL WEIGHT*  
**1,107 Kg/m**

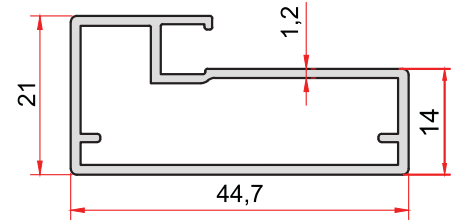

**KOD-CODE** *TEORİK AĞIRLIK*  
**1381** *THEORETICAL WEIGHT*  
**0,475 Kg/m**

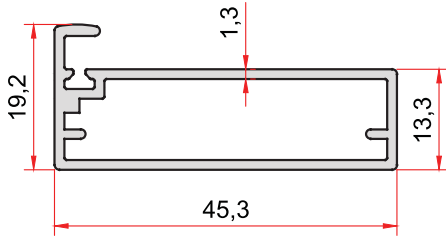

**KOD-CODE** *TEORİK AĞIRLIK*  
**1384** *THEORETICAL WEIGHT*  
**0,475 Kg/m**

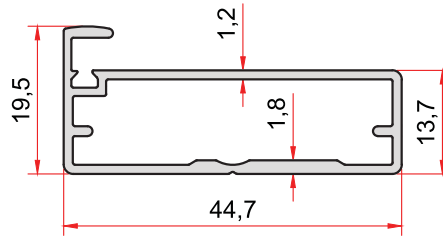

**KOD-CODE** *TEORİK AĞIRLIK*  
**1421** *THEORETICAL WEIGHT*  
**0,446 Kg/m**

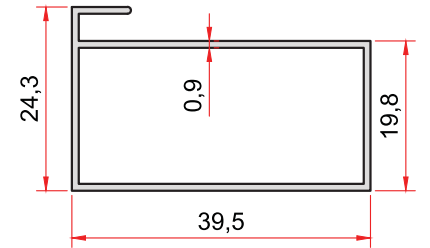

**KOD-CODE** *TEORİK AĞIRLIK*  
**1433** *THEORETICAL WEIGHT*  
**0,308 Kg/m**

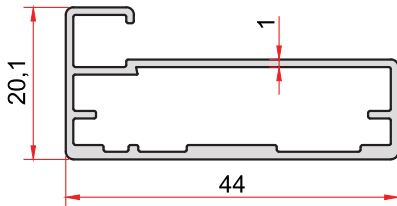

**KOD-CODE** *TEORİK AĞIRLIK*  
**1460** *THEORETICAL WEIGHT*  
**0,410 Kg/m**

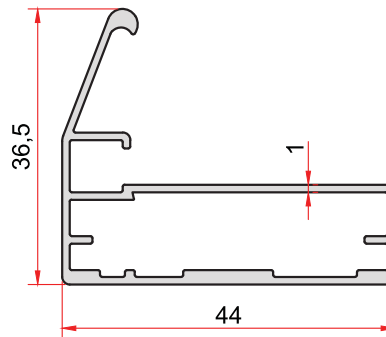

**KOD-CODE** *TEORİK AĞIRLIK*  
**1461** *THEORETICAL WEIGHT*  
**0,475 Kg/m**

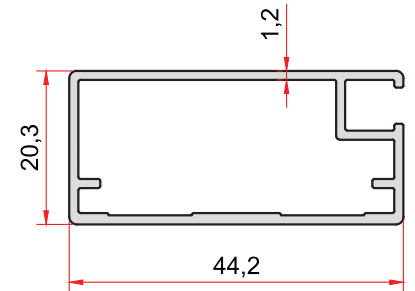

**KOD-CODE** *TEORİK AĞIRLIK*  
**1462** *THEORETICAL WEIGHT*  
**0,467 Kg/m**

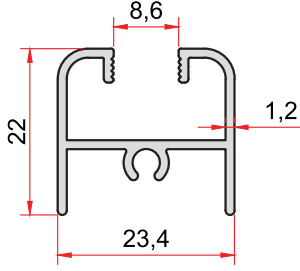

**KOD-CODE** *TEORİK AĞIRLIK*  
*THEORETICAL WEIGHT*  
**1361** **0,292 Kg/m**

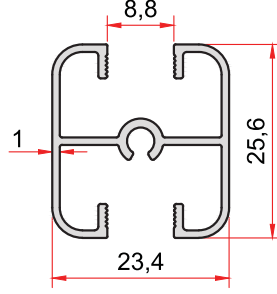

**KOD-CODE** *TEORİK AĞIRLIK*  
*THEORETICAL WEIGHT*  
**1362** **0,316 Kg/m**

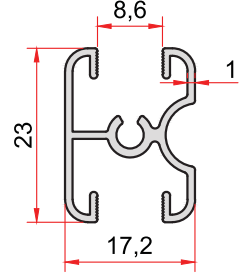

**KOD-CODE** *TEORİK AĞIRLIK*  
*THEORETICAL WEIGHT*  
**1394** **0,243 Kg/m**

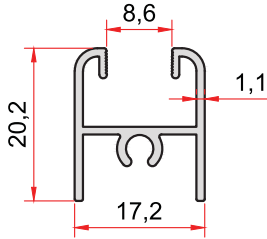

**KOD-CODE** *TEORİK AĞIRLIK*  
*THEORETICAL WEIGHT*  
**1395** **0,216 Kg/m**

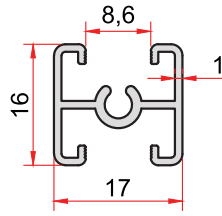

**KOD-CODE** *TEORİK AĞIRLIK*  
*THEORETICAL WEIGHT*  
**1398** **0,200 Kg/m**

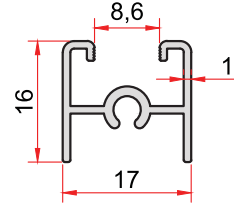

**KOD-CODE** *TEORİK AĞIRLIK*  
*THEORETICAL WEIGHT*  
**1399** **0,175 Kg/m**

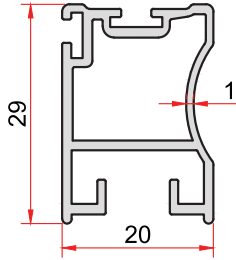

**KOD-CODE** *TEORİK AĞIRLIK*  
*THEORETICAL WEIGHT*  
**1397** **0,394 Kg/m**

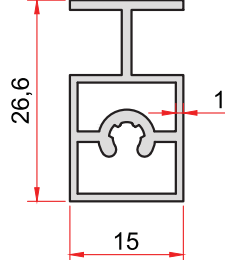

**KOD-CODE** *TEORİK AĞIRLIK*  
*THEORETICAL WEIGHT*  
**1369** **0,327 Kg/m**

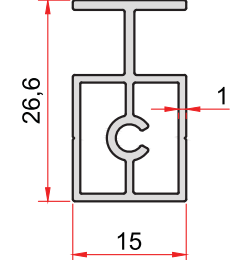

**KOD-CODE** *TEORİK AĞIRLIK*  
*THEORETICAL WEIGHT*  
**1468** **0,308 Kg/m**

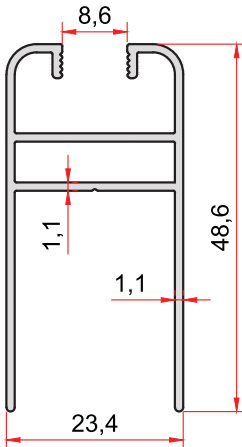

**KOD-CODE** *TEORİK AĞIRLIK*  
*THEORETICAL WEIGHT*  
**1360** **0,464 Kg/m**

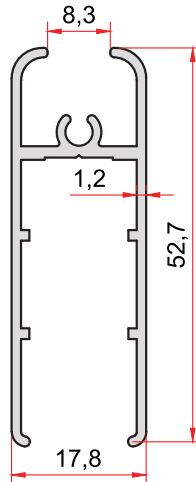

**KOD-CODE** *TEORİK AĞIRLIK*  
*THEORETICAL WEIGHT*  
**1396** **0,486 Kg/m**

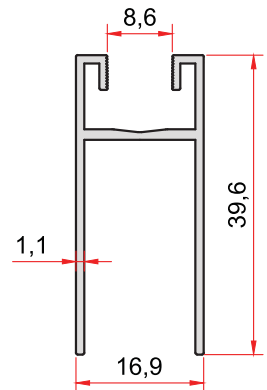

**KOD-CODE** *TEORİK AĞIRLIK*  
*THEORETICAL WEIGHT*  
**1400** **0,324 Kg/m**

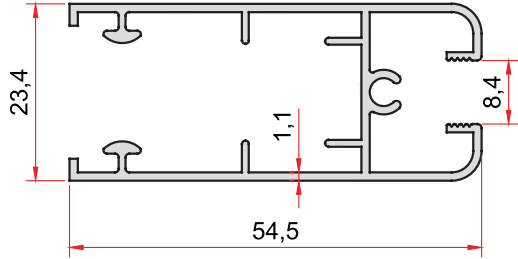

**KOD-CODE** *TEORİK AĞIRLIK*  
*THEORETICAL WEIGHT*  
**1370** **0,562 Kg/m**

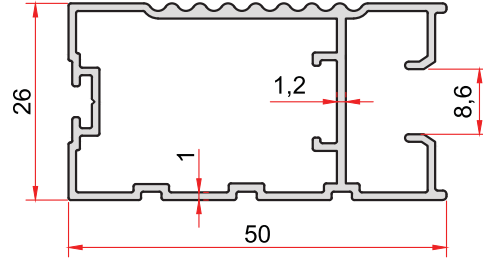

**KOD-CODE** *TEORİK AĞIRLIK*  
*THEORETICAL WEIGHT*  
**1357** **0,564 Kg/m**

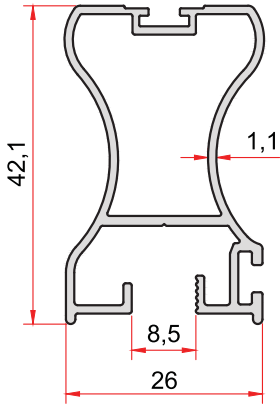

**KOD-CODE** *TEORİK AĞIRLIK*  
*THEORETICAL WEIGHT*  
**1363** **0,494 Kg/m**

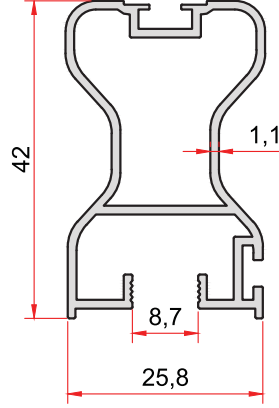

**KOD-CODE** *TEORİK AĞIRLIK*  
*THEORETICAL WEIGHT*  
**1365** **0,516 Kg/m**

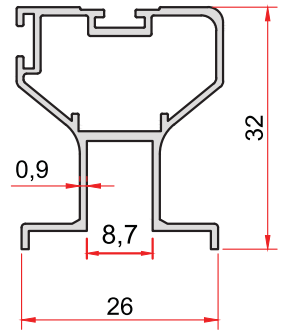

**KOD-CODE** *TEORİK AĞIRLIK*  
*THEORETICAL WEIGHT*  
**1380** **0,362 Kg/m**

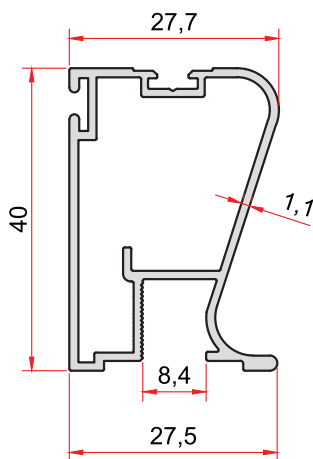

**KOD-CODE** *TEORİK AĞIRLIK*  
*THEORETICAL WEIGHT*  
**1393** **0,505 Kg/m**

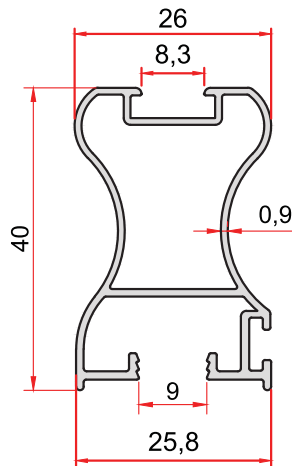

**KOD-CODE** *TEORİK AĞIRLIK*  
*THEORETICAL WEIGHT*  
**1452** **0,408 Kg/m**

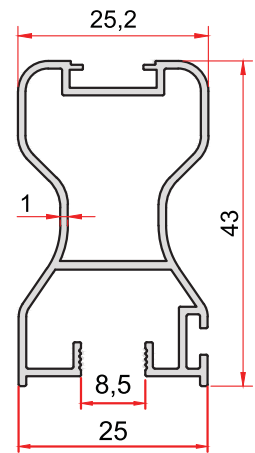

**KOD-CODE** *TEORİK AĞIRLIK*  
*THEORETICAL WEIGHT*  
**1459** **0,451 Kg/m**

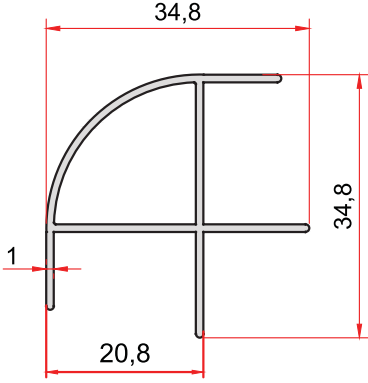

**KOD-CODE** *TEORİK AĞIRLIK*  
*THEORETICAL WEIGHT*  
**1390** **0,321 Kg/m**

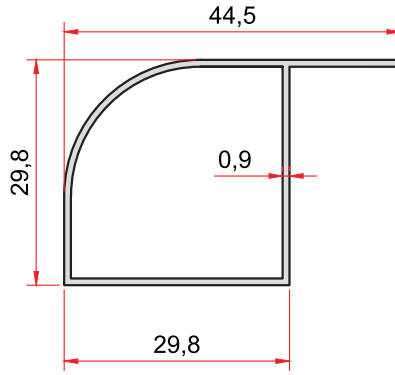

**KOD-CODE** *TEORİK AĞIRLIK*  
*THEORETICAL WEIGHT*  
**1434** **0,297 Kg/m**

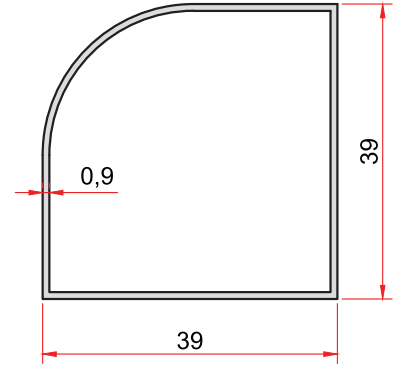

**KOD-CODE** *TEORİK AĞIRLIK*  
*THEORETICAL WEIGHT*  
**1437** **0,351 Kg/m**

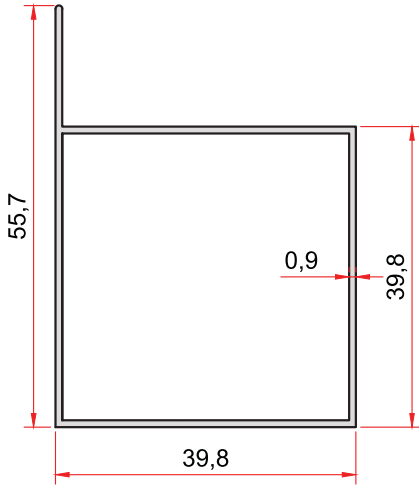

**KOD-CODE** *TEORİK AĞIRLIK*  
*THEORETICAL WEIGHT*  
**1435** **0,416 Kg/m**

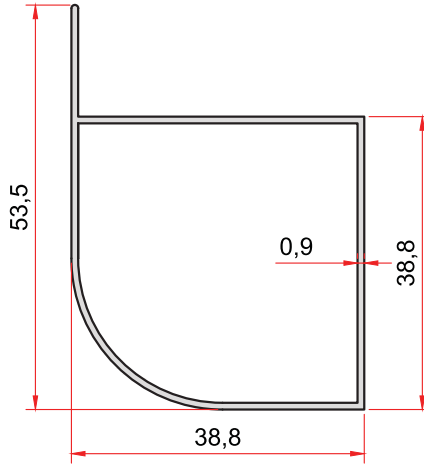

**KOD-CODE** *TEORİK AĞIRLIK*  
*THEORETICAL WEIGHT*  
**1436** **0,383 Kg/m**

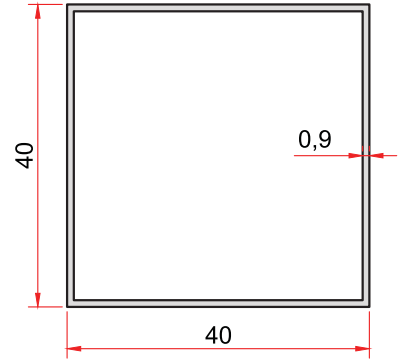

**KOD-CODE** *TEORİK AĞIRLIK*  
*THEORETICAL WEIGHT*  
**1438** **0,381 Kg/m**

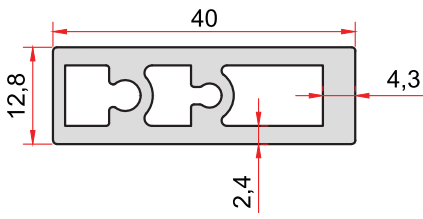

**KOD-CODE** *TEORİK AĞIRLIK*  
*THEORETICAL WEIGHT*  
**1499** **0,797 Kg/m**

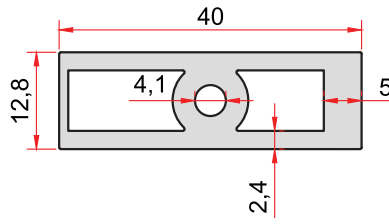

**KOD-CODE** *TEORİK AĞIRLIK*  
*THEORETICAL WEIGHT*  
**1493** **0,807 Kg/m**

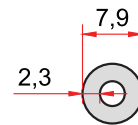

**KOD-CODE** *TEORİK AĞIRLIK*  
*THEORETICAL WEIGHT*  
**1504** **0,108 Kg/m**

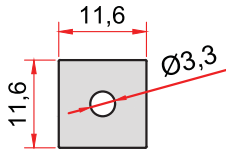

**KOD-CODE** *TEORİK AĞIRLIK*  
*THEORETICAL WEIGHT*  
**1480** **0,340 Kg/m**

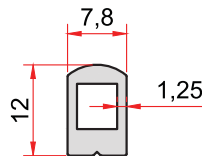

**KOD-CODE** *TEORİK AĞIRLIK*  
*THEORETICAL WEIGHT*  
**1494** **0,156 Kg/m**

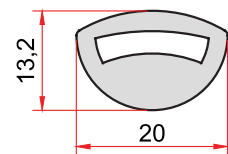

**KOD-CODE** *TEORİK AĞIRLIK*  
*THEORETICAL WEIGHT*  
**1410** **0,424 Kg/m**

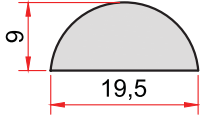

**KOD-CODE** *TEORİK AĞIRLIK*  
*THEORETICAL WEIGHT*  
1417 0,364 Kg/m

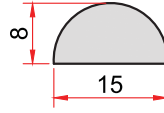

**KOD-CODE** *TEORİK AĞIRLIK*  
*THEORETICAL WEIGHT*  
1443 0,259 Kg/m

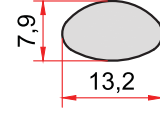

**KOD-CODE** *TEORİK AĞIRLIK*  
*THEORETICAL WEIGHT*  
1472 0,219 Kg/m

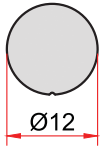

**KOD-CODE** *TEORİK AĞIRLIK*  
*THEORETICAL WEIGHT*  
1479 0,305 Kg/m

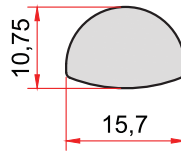

**KOD-CODE** *TEORİK AĞIRLIK*  
*THEORETICAL WEIGHT*  
1491 0,362 Kg/m

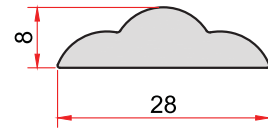

**KOD-CODE** *TEORİK AĞIRLIK*  
*THEORETICAL WEIGHT*  
1444 0,389 Kg/m

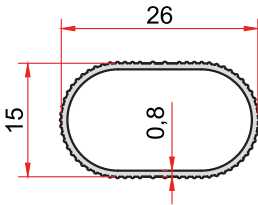

**KOD-CODE** *TEORİK AĞIRLIK*  
*THEORETICAL WEIGHT*  
871 0,157 Kg/m

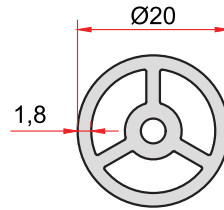

**KOD-CODE** *TEORİK AĞIRLIK*  
*THEORETICAL WEIGHT*  
1496 0,440 Kg/m

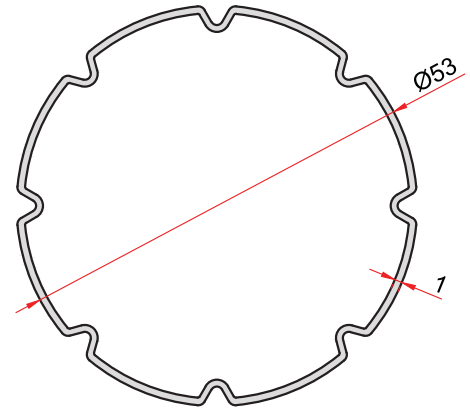

**KOD-CODE** *TEORİK AĞIRLIK*  
*THEORETICAL WEIGHT*  
1445 0,478 Kg/m

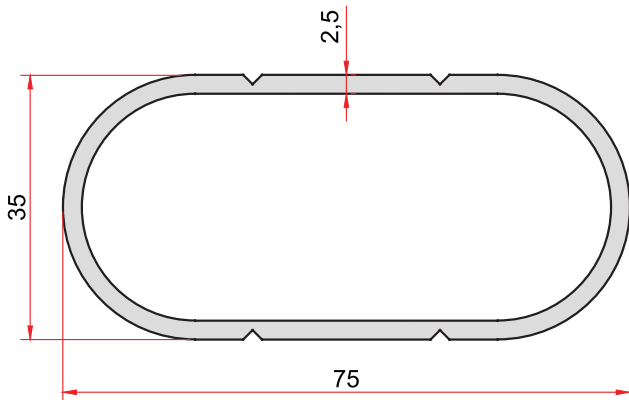

**KOD-CODE** *TEORİK AĞIRLIK*  
*THEORETICAL WEIGHT*  
1419 1,212 Kg/m

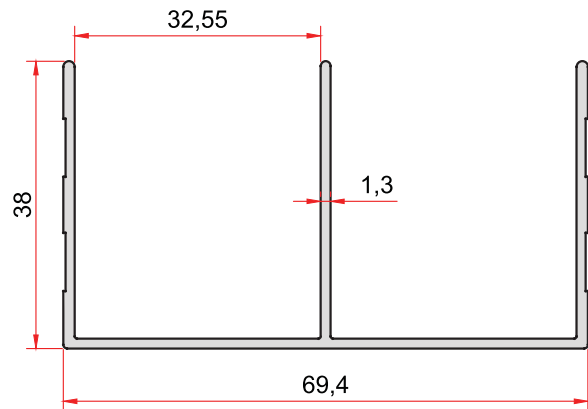

**KOD-CODE** *TEORİK AĞIRLIK*  
*THEORETICAL WEIGHT*  
1358 0,641 Kg/m



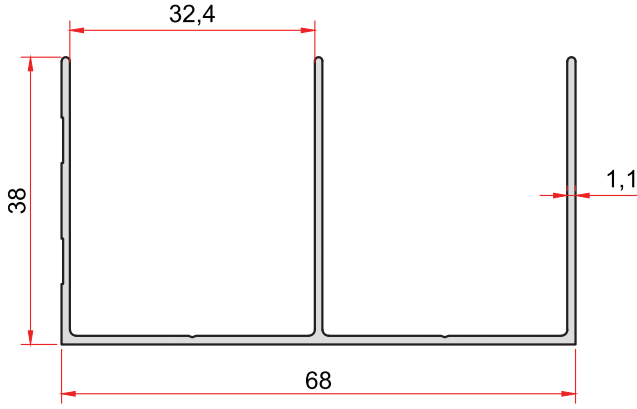

**KOD-CODE** *TEORİK AĞIRLIK*  
*THEORETICAL WEIGHT*  
**1371** **0,524 Kg/m**

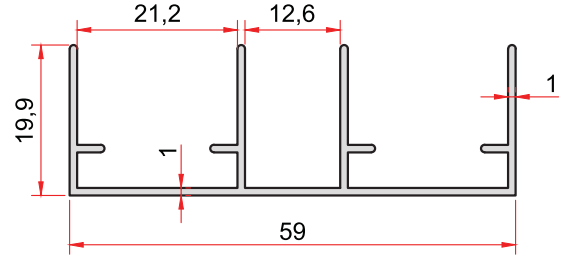

**KOD-CODE** *TEORİK AĞIRLIK*  
*THEORETICAL WEIGHT*  
**1382** **0,400 Kg/m**

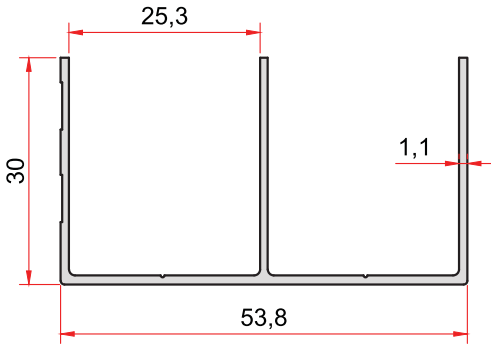

**KOD-CODE** *TEORİK AĞIRLIK*  
*THEORETICAL WEIGHT*  
**1401** **0,416 Kg/m**

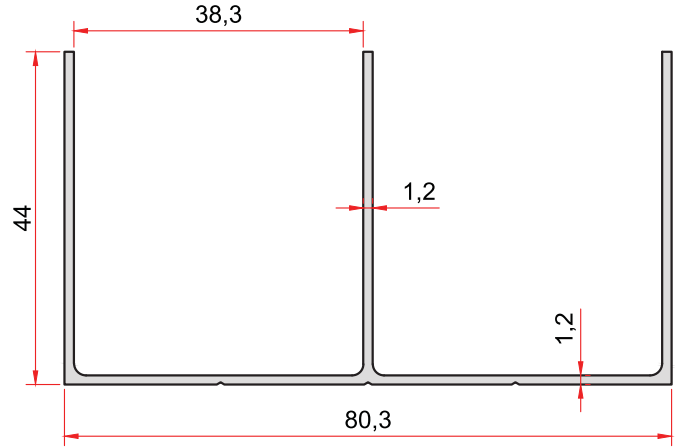

**KOD-CODE** *TEORİK AĞIRLIK*  
*THEORETICAL WEIGHT*  
**1424** **0,697 Kg/m**

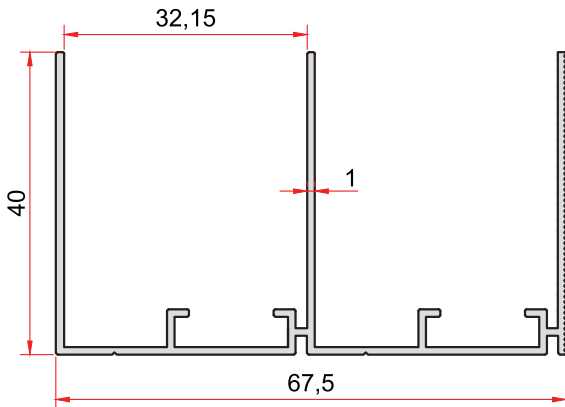

**KOD-CODE** *TEORİK AĞIRLIK*  
*THEORETICAL WEIGHT*  
**1442** **0,583 Kg/m**

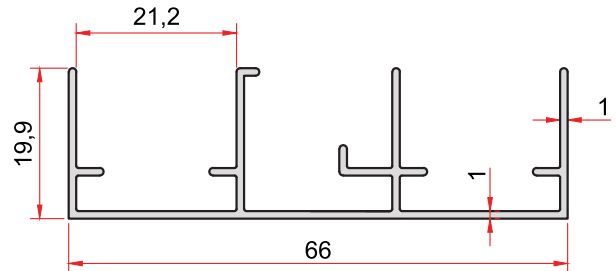

**KOD-CODE** *TEORİK AĞIRLIK*  
*THEORETICAL WEIGHT*  
**1453** **0,451 Kg/m**

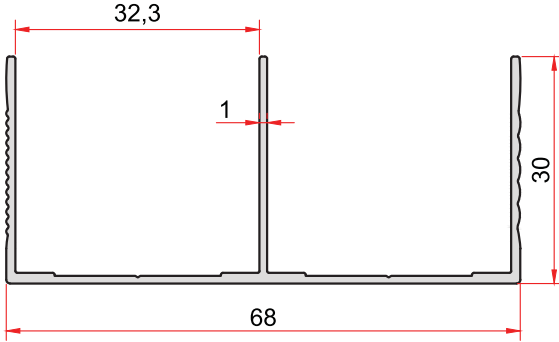

**KOD-CODE** *TEORİK AĞIRLIK*  
*THEORETICAL WEIGHT*  
**1457** **0,456 Kg/m**

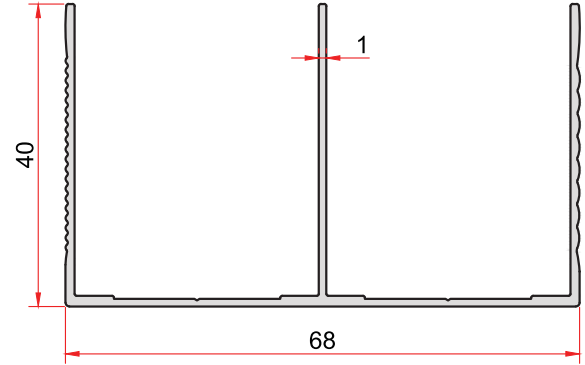

**KOD-CODE** *TEORİK AĞIRLIK*  
*THEORETICAL WEIGHT*  
**1458** **0,543 Kg/m**

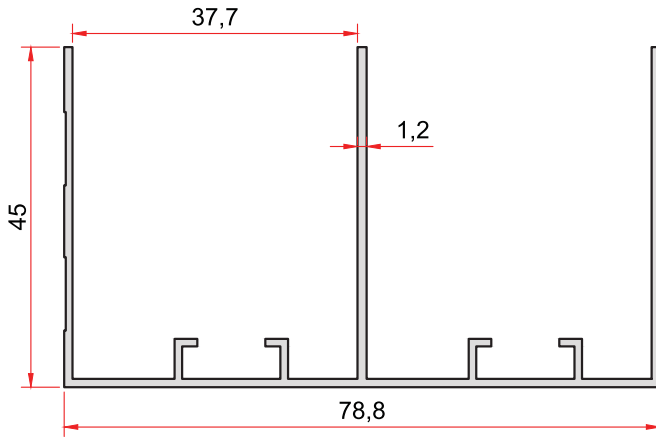

**KOD-CODE** *TEORİK AĞIRLIK*  
*THEORETICAL WEIGHT*  
**1482** **0,694 Kg/m**

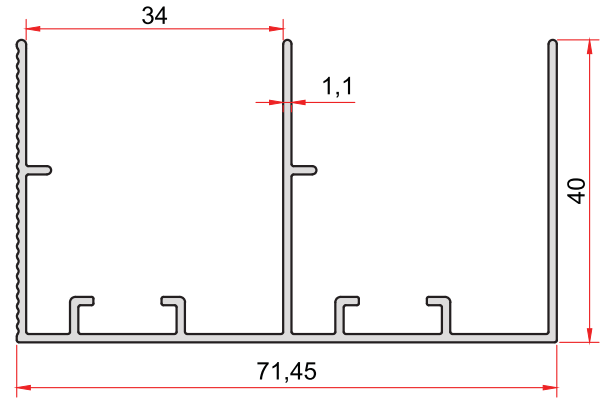

**KOD-CODE** *TEORİK AĞIRLIK*  
*THEORETICAL WEIGHT*  
**1485** **0,661 Kg/m**

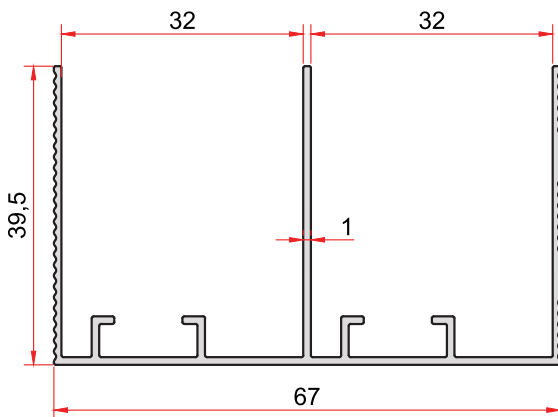

**KOD-CODE** *TEORİK AĞIRLIK*  
*THEORETICAL WEIGHT*  
**1502** **0,545 Kg/m**

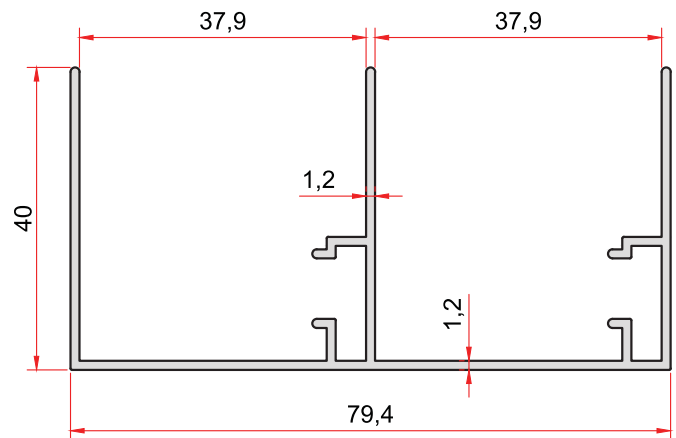

**KOD-CODE** *TEORİK AĞIRLIK*  
*THEORETICAL WEIGHT*  
**1489** **0,737 Kg/m**

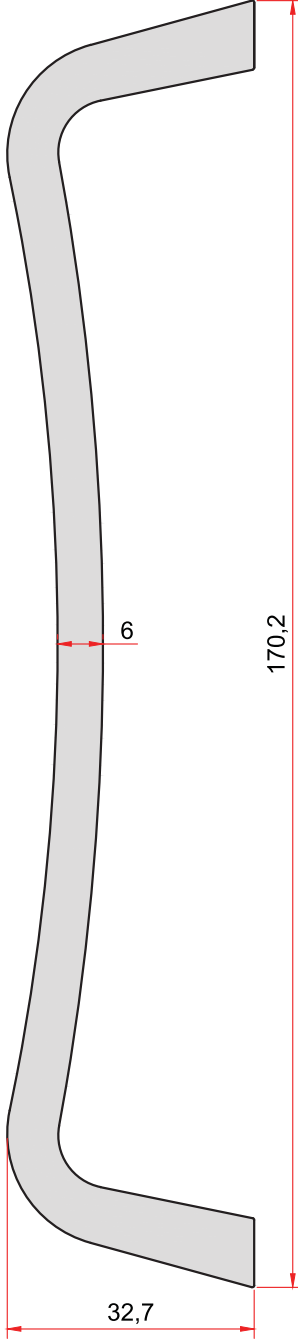

**KOD-CODE** *TEORİK AĞIRLIK*  
*THEORETICAL WEIGHT*  
**1477** **3,717 Kg/m**

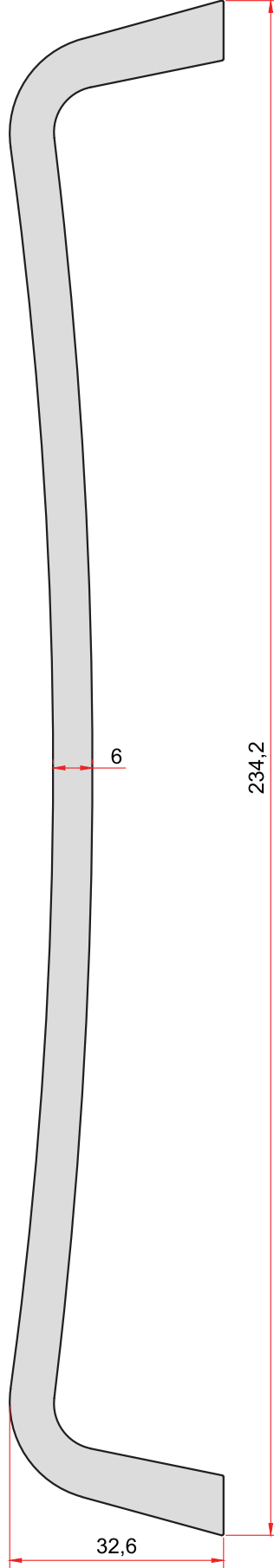

**KOD-CODE** *TEORİK AĞIRLIK*  
*THEORETICAL WEIGHT*  
**1478** **4,790 Kg/m**









**ARFEM**<sup>®</sup>  
ALÜMİNYUM

**Duşakabin Profilleri**

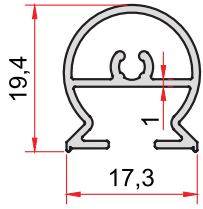

**KOD-CODE** *TEORİK AĞIRLIK*  
*THEORETICAL WEIGHT*  
**1751** **0,229 Kg/m**

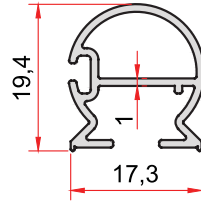

**KOD-CODE** *TEORİK AĞIRLIK*  
*THEORETICAL WEIGHT*  
**1752** **0,216 Kg/m**

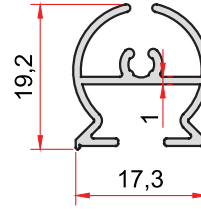

**KOD-CODE** *TEORİK AĞIRLIK*  
*THEORETICAL WEIGHT*  
**1753** **0,219 Kg/m**

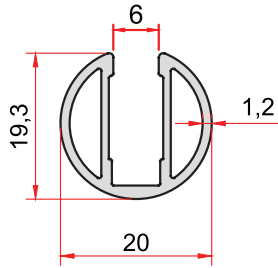

**KOD-CODE** *TEORİK AĞIRLIK*  
*THEORETICAL WEIGHT*  
**1769** **0,275 Kg/m**

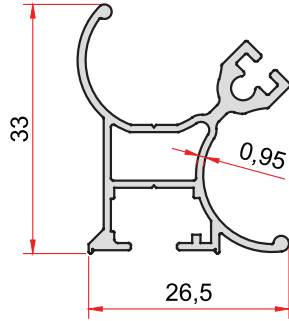

**KOD-CODE** *TEORİK AĞIRLIK*  
*THEORETICAL WEIGHT*  
**1757** **0,386 Kg/m**

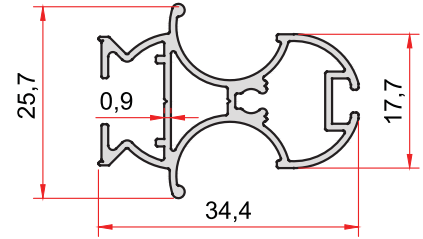

**KOD-CODE** *TEORİK AĞIRLIK*  
*THEORETICAL WEIGHT*  
**1755** **0,385 Kg/m**

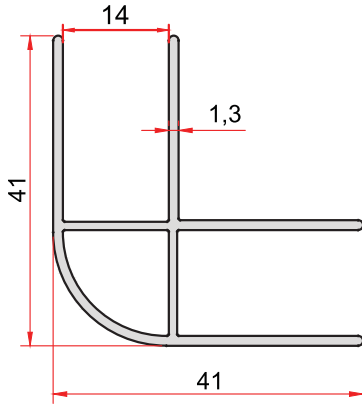

**KOD-CODE** *TEORİK AĞIRLIK*  
*THEORETICAL WEIGHT*  
**1766** **0,518 Kg/m**

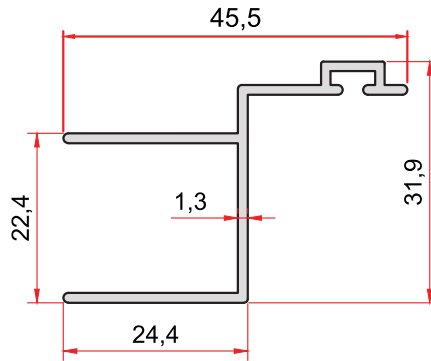

**KOD-CODE** *TEORİK AĞIRLIK*  
*THEORETICAL WEIGHT*  
**1782** **0,364 Kg/m**

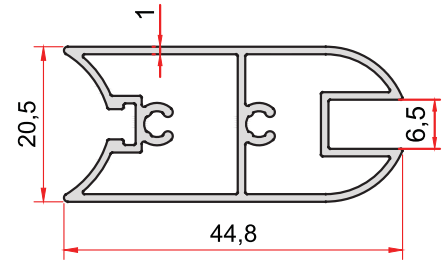

**KOD-CODE** *TEORİK AĞIRLIK*  
*THEORETICAL WEIGHT*  
**1772** **0,518 Kg/m**

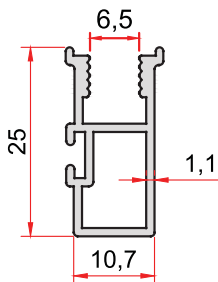

**KOD-CODE** *TEORİK AĞIRLIK*  
*THEORETICAL WEIGHT*  
**1783** **0,248 Kg/m**

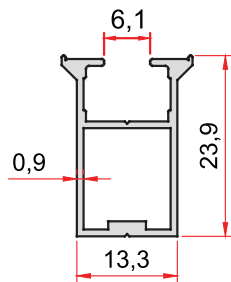

**KOD-CODE** *TEORİK AĞIRLIK*  
*THEORETICAL WEIGHT*  
**1763** **0,224 Kg/m**

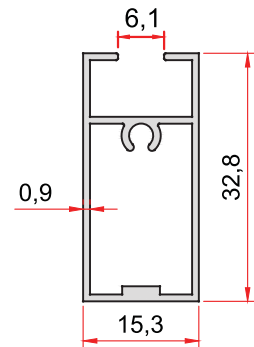

**KOD-CODE** *TEORİK AĞIRLIK*  
*THEORETICAL WEIGHT*  
**1759** **0,278 Kg/m**



# Duřakabin Profilleri

**ARFEM**<sup>®</sup>  
ALÜMİNYUM

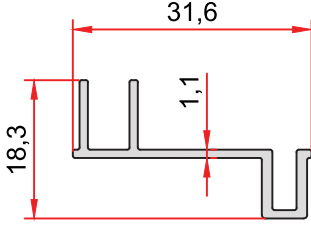

**KOD-CODE** *TEORİK AĞIRLIK*  
*THEORETICAL WEIGHT*  
**1789** **0,207 Kg/m**

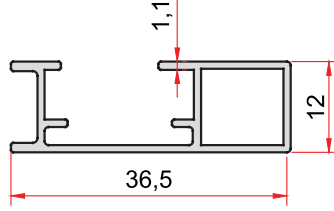

**KOD-CODE** *TEORİK AĞIRLIK*  
*THEORETICAL WEIGHT*  
**1761** **0,259 Kg/m**

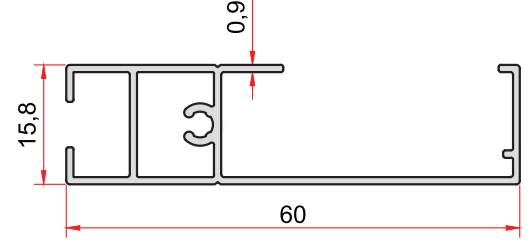

**KOD-CODE** *TEORİK AĞIRLIK*  
*THEORETICAL WEIGHT*  
**1765** **0,391 Kg/m**

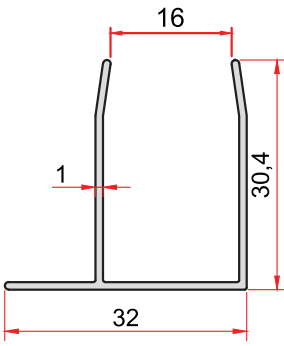

**KOD-CODE** *TEORİK AĞIRLIK*  
*THEORETICAL WEIGHT*  
**1767** **0,243 Kg/m**

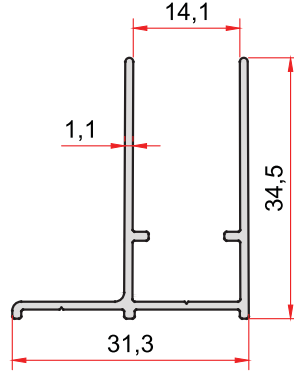

**KOD-CODE** *TEORİK AĞIRLIK*  
*THEORETICAL WEIGHT*  
**1768** **0,308 Kg/m**

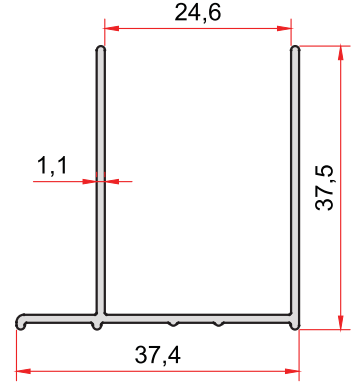

**KOD-CODE** *TEORİK AĞIRLIK*  
*THEORETICAL WEIGHT*  
**1774** **0,321 Kg/m**

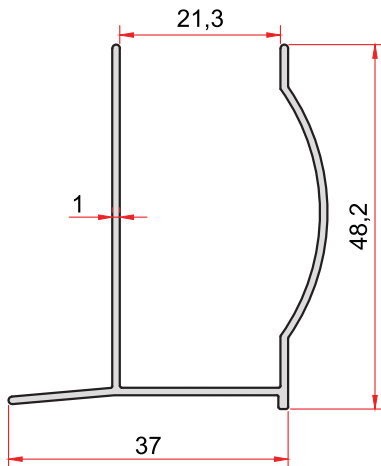

**KOD-CODE** *TEORİK AĞIRLIK*  
*THEORETICAL WEIGHT*  
**1771** **0,356 Kg/m**

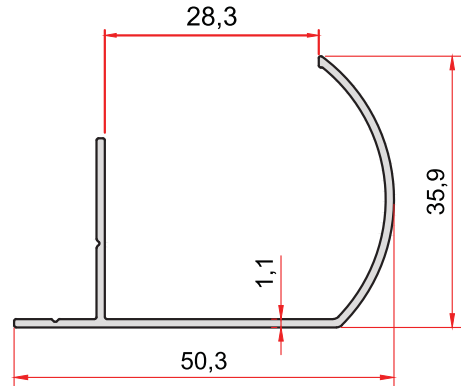

**KOD-CODE** *TEORİK AĞIRLIK*  
*THEORETICAL WEIGHT*  
**1756** **0,313 Kg/m**

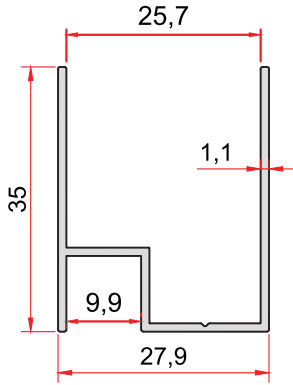

**KOD-CODE** *TEORİK AĞIRLIK*  
**1758** *THEORETICAL WEIGHT*  
**0,313 Kg/m**

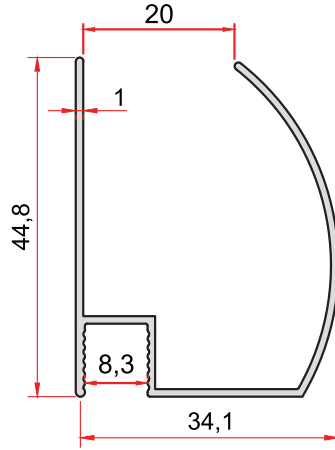

**KOD-CODE** *TEORİK AĞIRLIK*  
**1764** *THEORETICAL WEIGHT*  
**0,353 Kg/m**

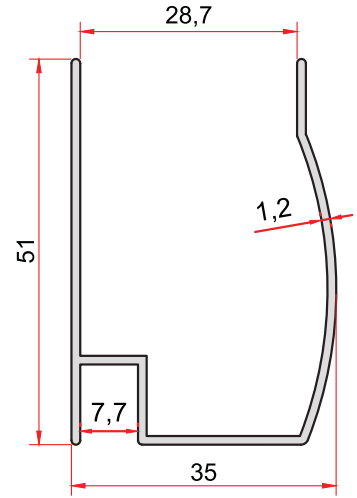

**KOD-CODE** *TEORİK AĞIRLIK*  
**1777** *THEORETICAL WEIGHT*  
**0,440 Kg/m**

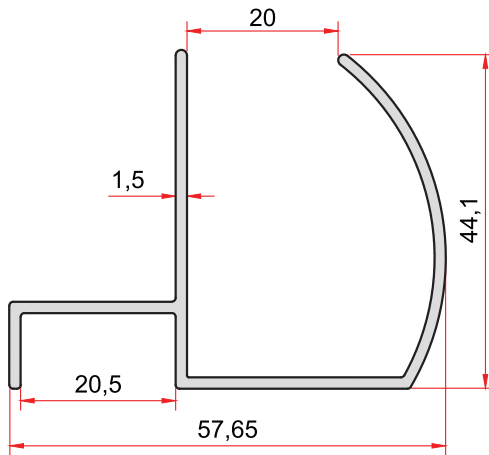

**KOD-CODE** *TEORİK AĞIRLIK*  
**1788** *THEORETICAL WEIGHT*  
**0,621 Kg/m**

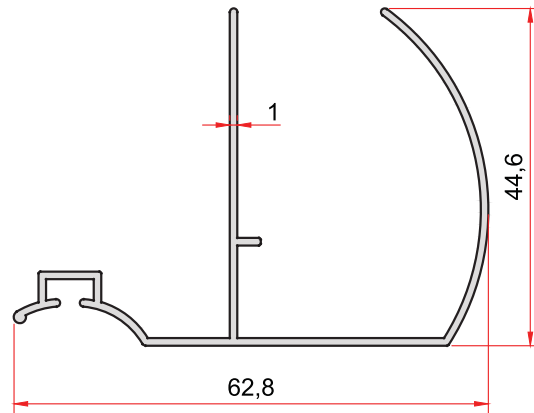

**KOD-CODE** *TEORİK AĞIRLIK*  
**1784** *THEORETICAL WEIGHT*  
**0,451 Kg/m**

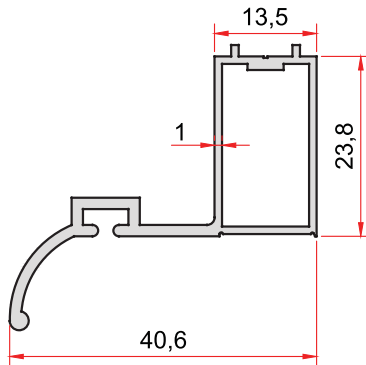

**KOD-CODE** *TEORİK AĞIRLIK*  
**1780** *THEORETICAL WEIGHT*  
**0,399 Kg/m**

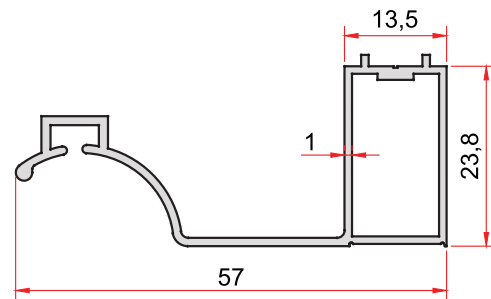

**KOD-CODE** *TEORİK AĞIRLIK*  
**1781** *THEORETICAL WEIGHT*  
**0,400 Kg/m**



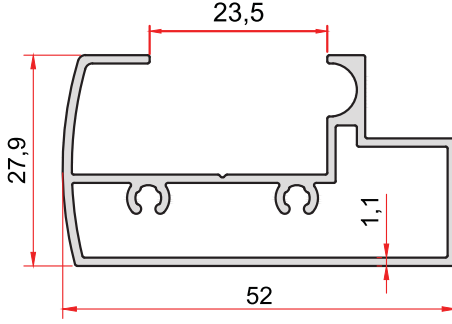

**KOD-CODE** TEORİK AĞIRLIK  
1754 THEORETICAL WEIGHT  
0,596 Kg/m

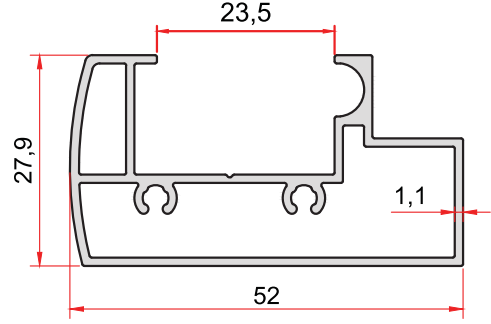

**KOD-CODE** TEORİK AĞIRLIK  
1762 THEORETICAL WEIGHT  
0,640 Kg/m

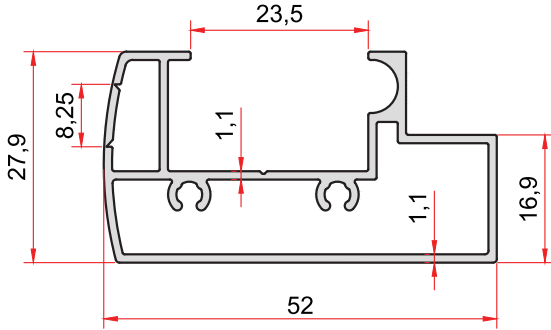

**KOD-CODE** TEORİK AĞIRLIK  
1787 THEORETICAL WEIGHT  
0,632 Kg/m

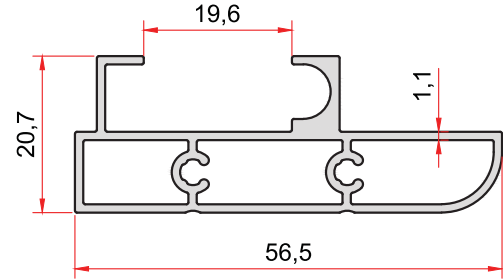

**KOD-CODE** TEORİK AĞIRLIK  
1786 THEORETICAL WEIGHT  
0,594 Kg/m

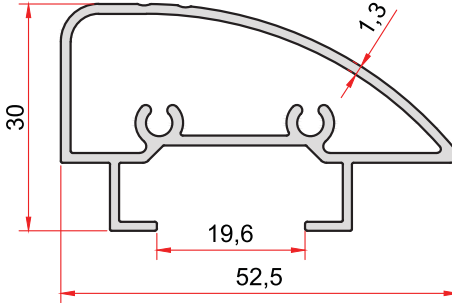

**KOD-CODE** TEORİK AĞIRLIK  
1773 THEORETICAL WEIGHT  
0,613 Kg/m

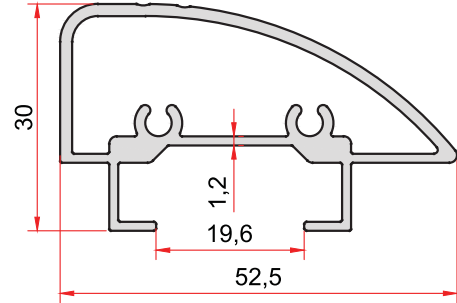

**KOD-CODE** TEORİK AĞIRLIK  
1775 THEORETICAL WEIGHT  
0,726 Kg/m

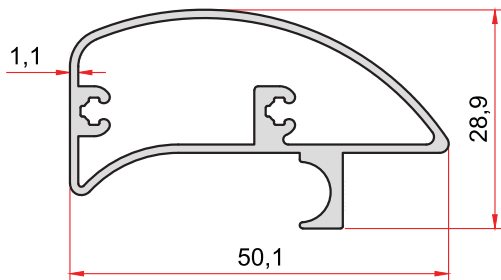

**KOD-CODE** TEORİK AĞIRLIK  
1779 THEORETICAL WEIGHT  
0,575 Kg/m

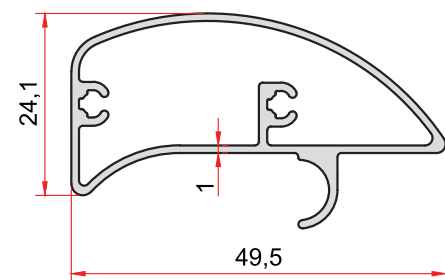

**KOD-CODE** TEORİK AĞIRLIK  
1770 THEORETICAL WEIGHT  
0,475 Kg/m

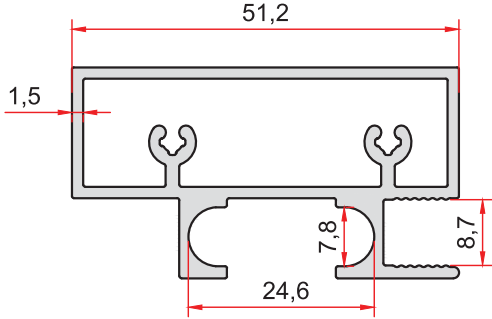

**KOD-CODE** *TEORİK AĞIRLIK*  
*THEORETICAL WEIGHT*  
**1790** **0,885 Kg/m**

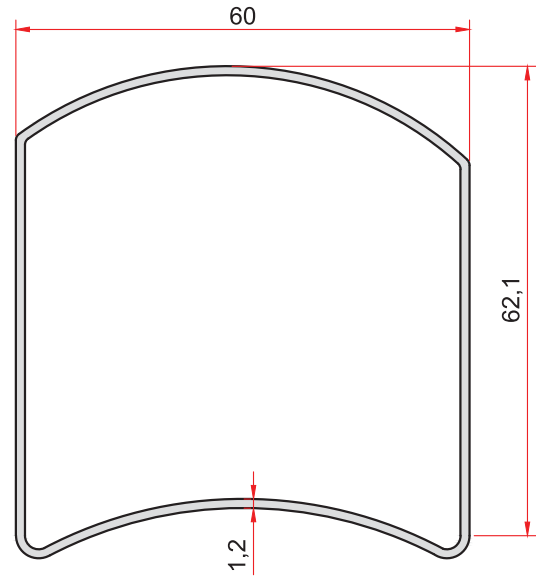

**KOD-CODE** *TEORİK AĞIRLIK*  
*THEORETICAL WEIGHT*  
**1760** **0,742 Kg/m**

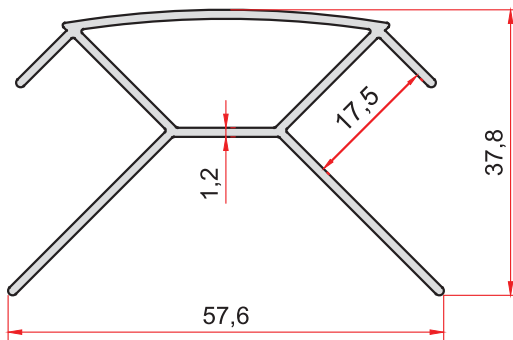

**KOD-CODE** *TEORİK AĞIRLIK*  
*THEORETICAL WEIGHT*  
**1785** **0,562 Kg/m**

**ARFEM**<sup>®</sup>  
ALÜMİNYUM

**Küpeşte Profilleri**

**ARFEM**  
ALUMINIUM  
[www.arfemaluminium.com](http://www.arfemaluminium.com)

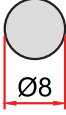

**KOD-CODE** *TEORİK AĞIRLIK*  
*THEORETICAL WEIGHT*  
146 0,136 Kg/m

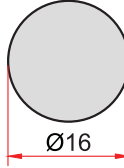

**KOD-CODE** *TEORİK AĞIRLIK*  
*THEORETICAL WEIGHT*  
6 0,542 Kg/m

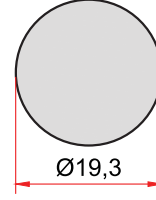

**KOD-CODE** *TEORİK AĞIRLIK*  
*THEORETICAL WEIGHT*  
128 0,791 Kg/m

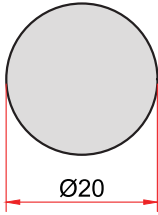

**KOD-CODE** *TEORİK AĞIRLIK*  
*THEORETICAL WEIGHT*  
8 0,847 Kg/m

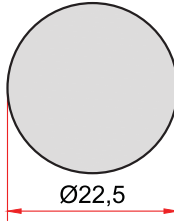

**KOD-CODE** *TEORİK AĞIRLIK*  
*THEORETICAL WEIGHT*  
9 1,074 Kg/m

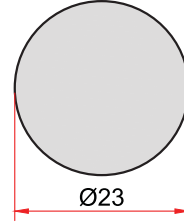

**KOD-CODE** *TEORİK AĞIRLIK*  
*THEORETICAL WEIGHT*  
127 1,120 Kg/m

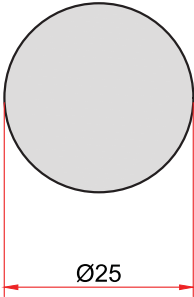

**KOD-CODE** *TEORİK AĞIRLIK*  
*THEORETICAL WEIGHT*  
126 1,326 Kg/m

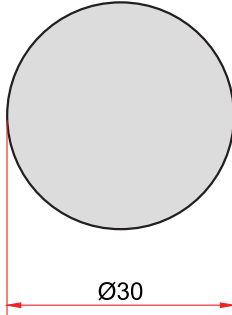

**KOD-CODE** *TEORİK AĞIRLIK*  
*THEORETICAL WEIGHT*  
7 1,906 Kg/m

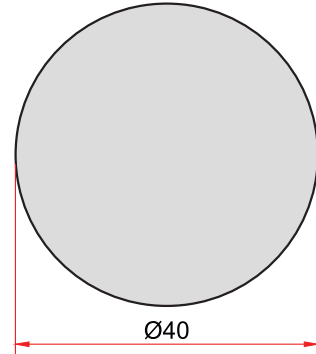

**KOD-CODE** *TEORİK AĞIRLIK*  
*THEORETICAL WEIGHT*  
5 3,391 Kg/m

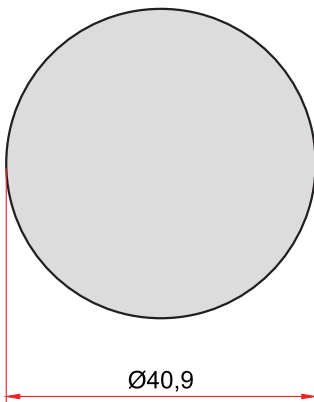

**KOD-CODE** *TEORİK AĞIRLIK*  
*THEORETICAL WEIGHT*  
136 3,548 Kg/m

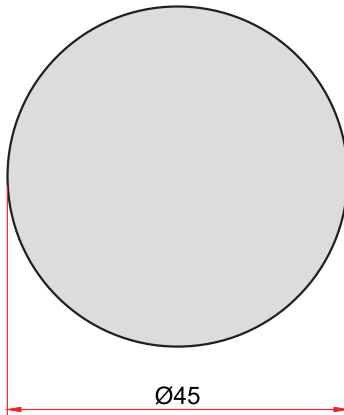

**KOD-CODE** *TEORİK AĞIRLIK*  
*THEORETICAL WEIGHT*  
130 4,293 Kg/m

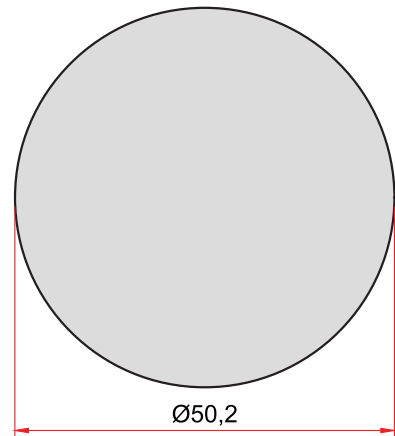

**KOD-CODE** *TEORİK AĞIRLIK*  
*THEORETICAL WEIGHT*  
3 5,364 Kg/m

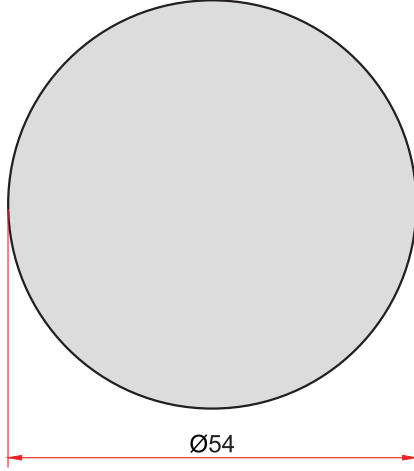

**KOD-CODE** *TEORİK AĞIRLIK*  
*THEORETICAL WEIGHT*  
30 6,183 Kg/m

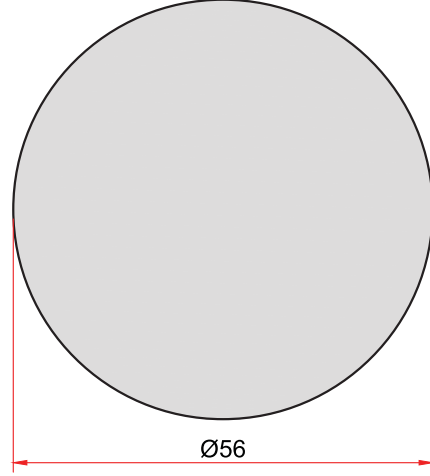

**KOD-CODE** *TEORİK AĞIRLIK*  
*THEORETICAL WEIGHT*  
4 6,531 Kg/m

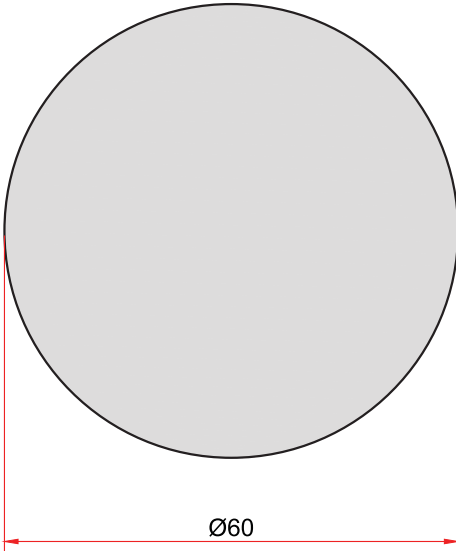

**KOD-CODE** *TEORİK AĞIRLIK*  
*THEORETICAL WEIGHT*  
137 7,633 Kg/m

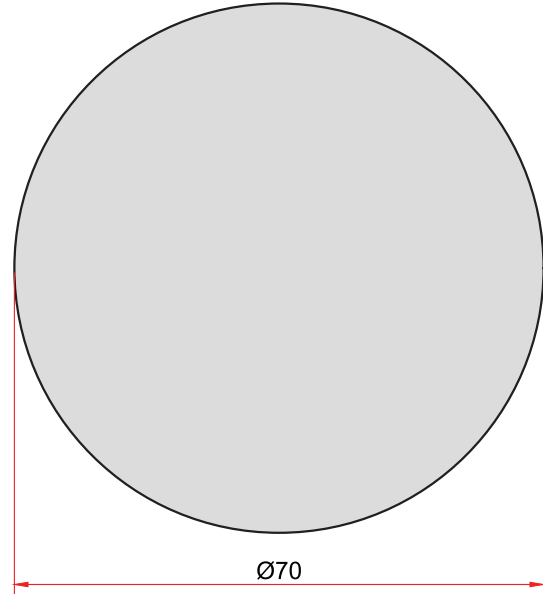

**KOD-CODE** *TEORİK AĞIRLIK*  
*THEORETICAL WEIGHT*  
1871 10,390 Kg/m

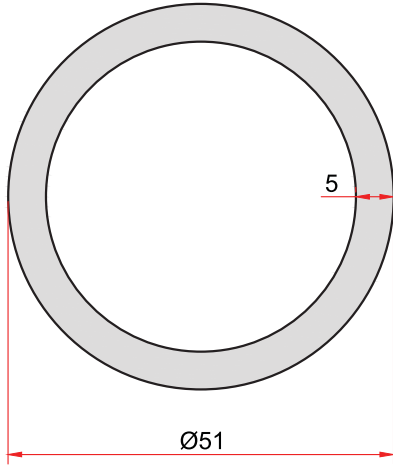

**KOD-CODE** *TEORİK AĞIRLIK*  
*THEORETICAL WEIGHT*  
**1918** **1,952 Kg/m**

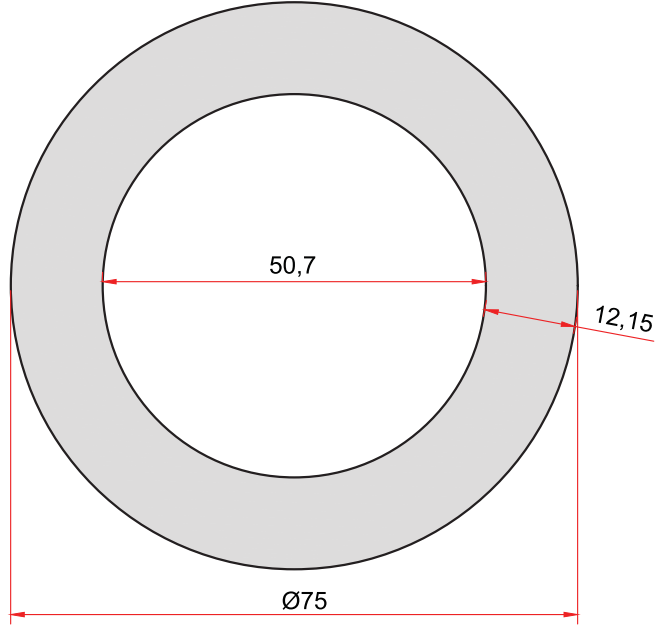

**KOD-CODE** *TEORİK AĞIRLIK*  
*THEORETICAL WEIGHT*  
**5068** **6,480 Kg/m**

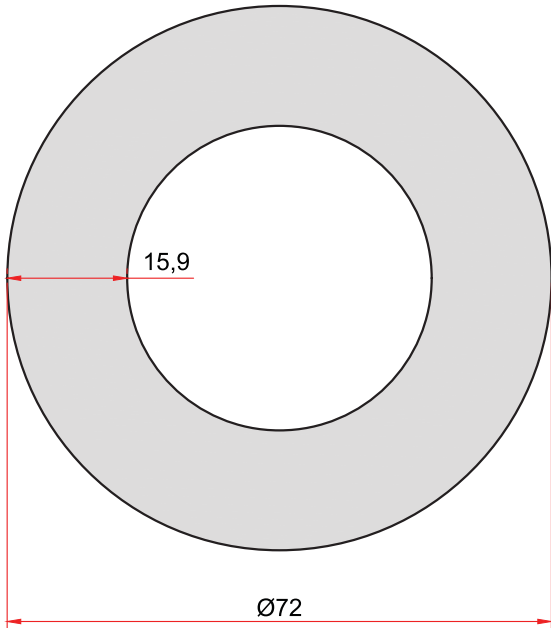

**KOD-CODE** *TEORİK AĞIRLIK*  
*THEORETICAL WEIGHT*  
**1852** **7,549 Kg/m**

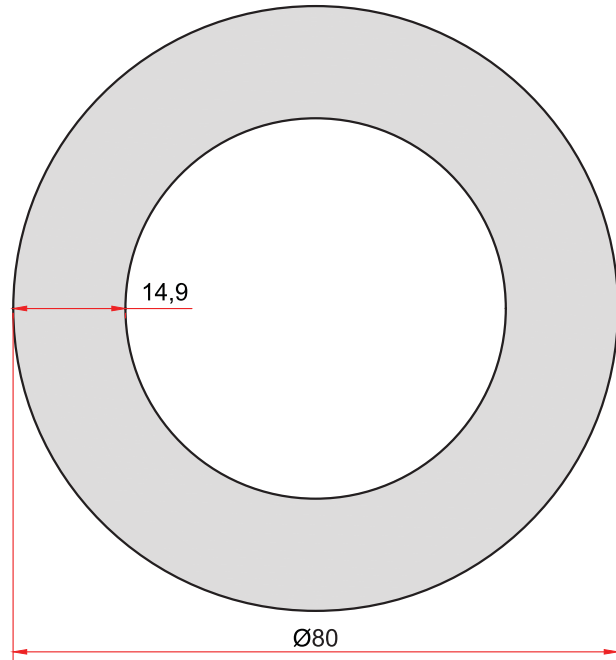

**KOD-CODE** *TEORİK AĞIRLIK*  
*THEORETICAL WEIGHT*  
**1851** **8,205 Kg/m**

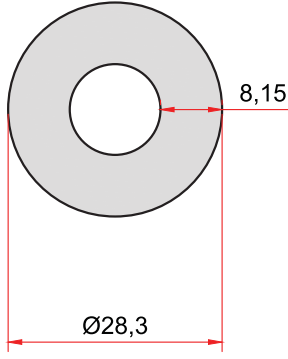

**KOD-CODE** *TEORİK AĞIRLIK*  
*THEORETICAL WEIGHT*  
5029 1,393 Kg/m

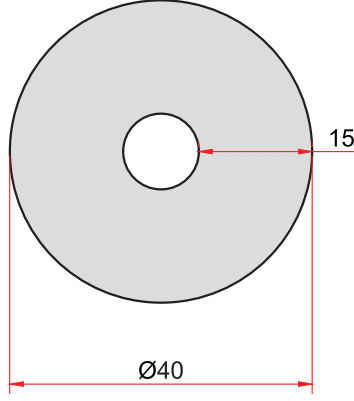

**KOD-CODE** *TEORİK AĞIRLIK*  
*THEORETICAL WEIGHT*  
1853 3,181 Kg/m

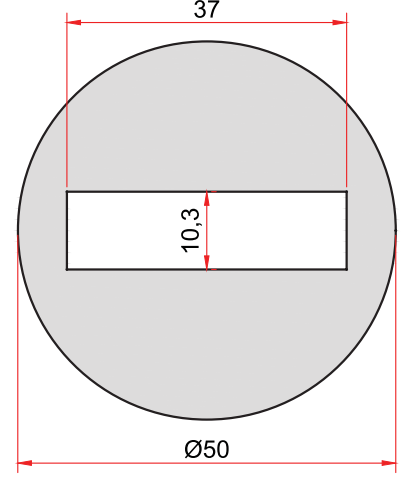

**KOD-CODE** *TEORİK AĞIRLIK*  
*THEORETICAL WEIGHT*  
1863 4,271 Kg/m

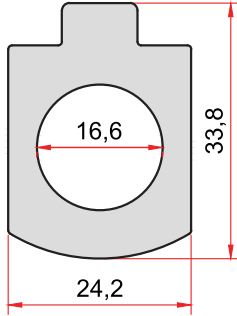

**KOD-CODE** *TEORİK AĞIRLIK*  
*THEORETICAL WEIGHT*  
1855 1,337 Kg/m

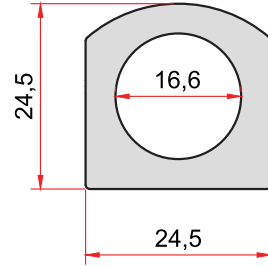

**KOD-CODE** *TEORİK AĞIRLIK*  
*THEORETICAL WEIGHT*  
1941 0,940 Kg/m

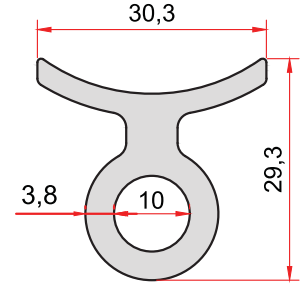

**KOD-CODE** *TEORİK AĞIRLIK*  
*THEORETICAL WEIGHT*  
5032 0,788 Kg/m

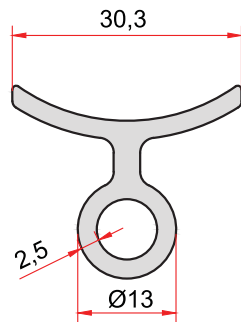

**KOD-CODE** *TEORİK AĞIRLIK*  
*THEORETICAL WEIGHT*  
5071 0,497 Kg/m

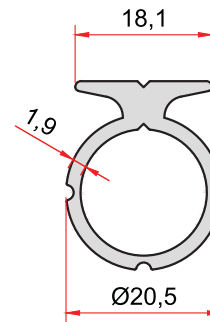

**KOD-CODE** *TEORİK AĞIRLIK*  
*THEORETICAL WEIGHT*  
5082 0,418 Kg/m

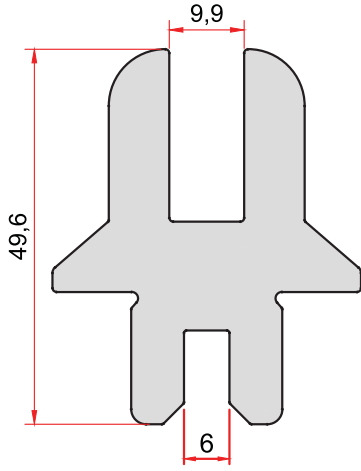

**KOD-CODE** TEORİK AĞIRLIK  
1856 2,530 Kg/m  
THEORETICAL WEIGHT

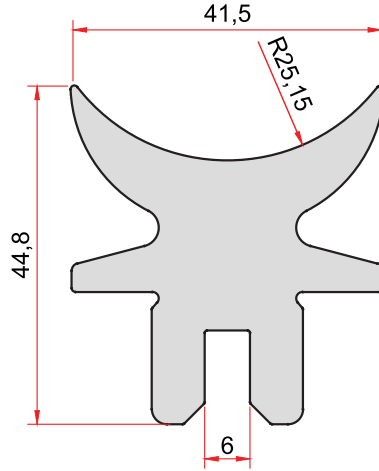

**KOD-CODE** TEORİK AĞIRLIK  
1857 2,403 Kg/m  
THEORETICAL WEIGHT

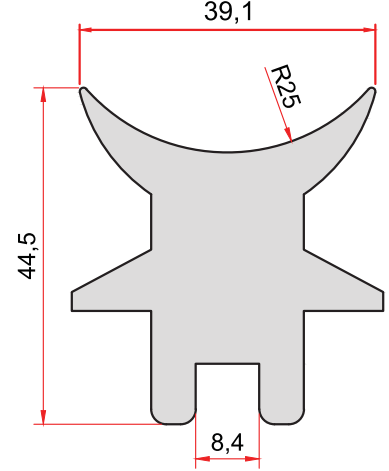

**KOD-CODE** TEORİK AĞIRLIK  
1966 2,397 Kg/m  
THEORETICAL WEIGHT

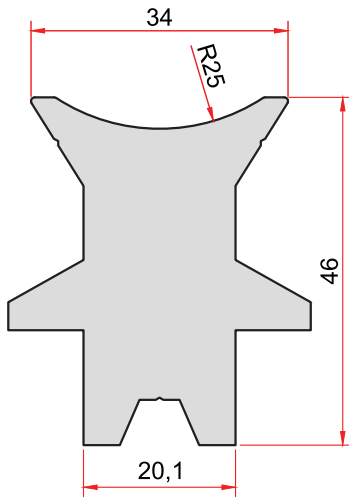

**KOD-CODE** TEORİK AĞIRLIK  
1967 2,738 Kg/m  
THEORETICAL WEIGHT

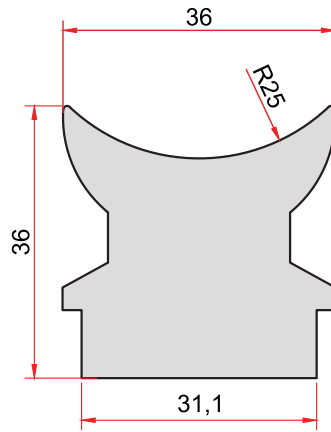

**KOD-CODE** TEORİK AĞIRLIK  
1970 2,549 Kg/m  
THEORETICAL WEIGHT

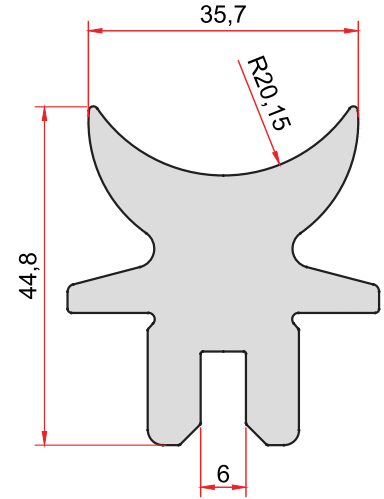

**KOD-CODE** TEORİK AĞIRLIK  
1866 2,400 Kg/m  
THEORETICAL WEIGHT

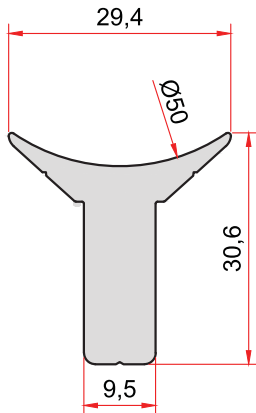

**KOD-CODE** TEORİK AĞIRLIK  
1942 0,853 Kg/m  
THEORETICAL WEIGHT

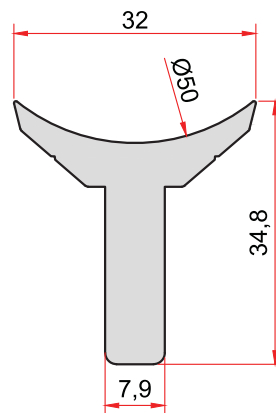

**KOD-CODE** TEORİK AĞIRLIK  
1892 0,934 Kg/m  
THEORETICAL WEIGHT

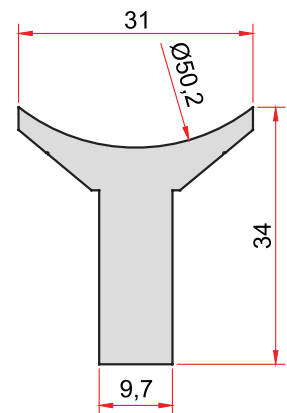

**KOD-CODE** TEORİK AĞIRLIK  
1862 1,007 Kg/m  
THEORETICAL WEIGHT



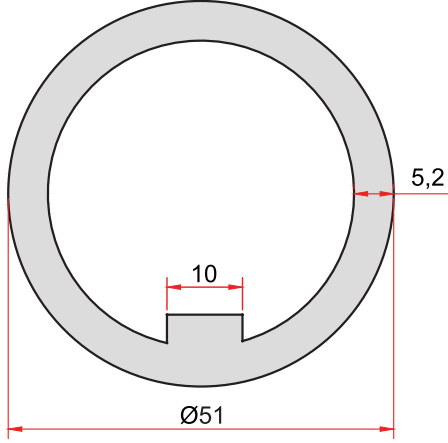

**KOD-CODE** *TEORİK AĞIRLIK*  
*THEORETICAL WEIGHT*  
**1860** **2,146 Kg/m**

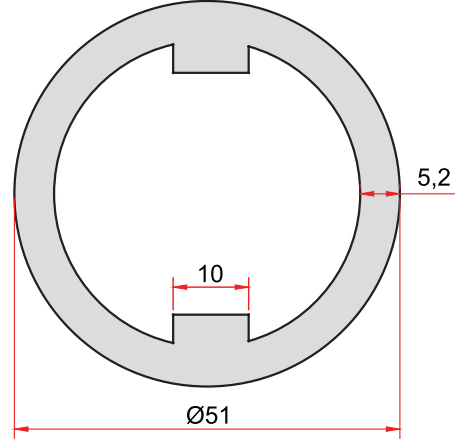

**KOD-CODE** *TEORİK AĞIRLIK*  
*THEORETICAL WEIGHT*  
**1861** **2,257 Kg/m**

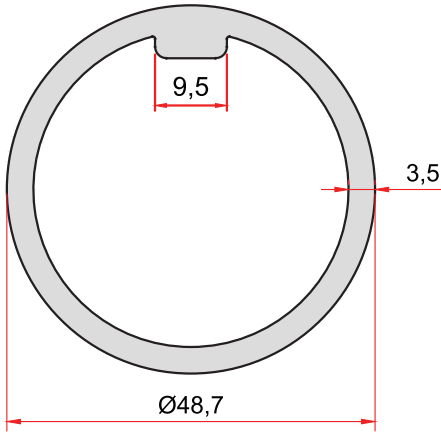

**KOD-CODE** *TEORİK AĞIRLIK*  
*THEORETICAL WEIGHT*  
**1854** **1,426 Kg/m**

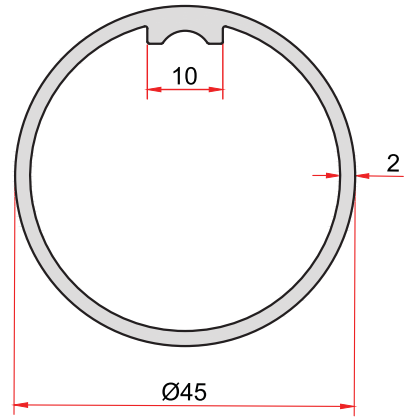

**KOD-CODE** *TEORİK AĞIRLIK*  
*THEORETICAL WEIGHT*  
**1969** **0,785 Kg/m**

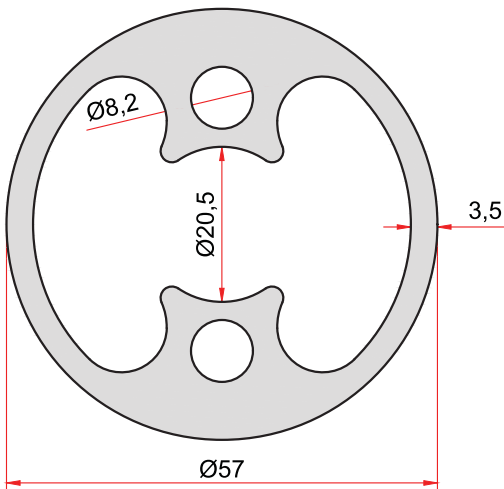

**KOD-CODE** *TEORİK AĞIRLIK*  
*THEORETICAL WEIGHT*  
**1865** **2,843 Kg/m**

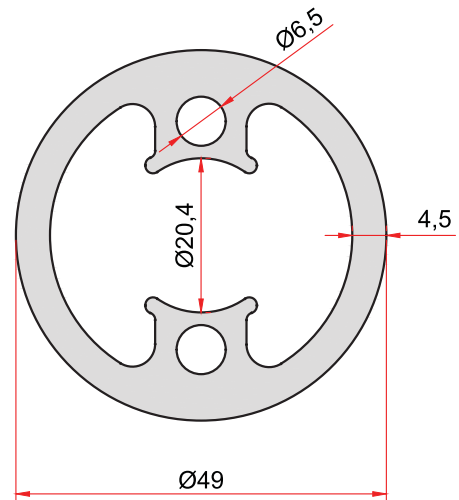

**KOD-CODE** *TEORİK AĞIRLIK*  
*THEORETICAL WEIGHT*  
**1873** **2,265 Kg/m**

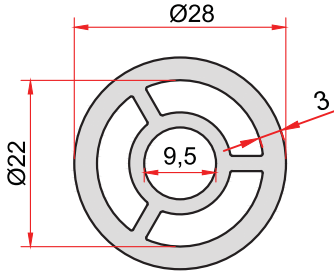

**KOD-CODE** *TEORİK AĞIRLIK*  
**5070** *THEORETICAL WEIGHT*  
**0,899 Kg/m**

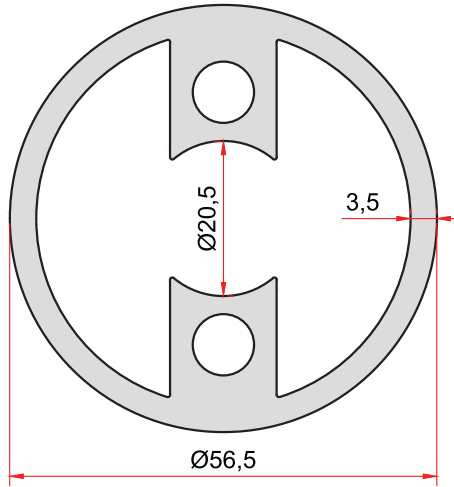

**KOD-CODE** *TEORİK AĞIRLIK*  
**1971** *THEORETICAL WEIGHT*  
**2,440 Kg/m**

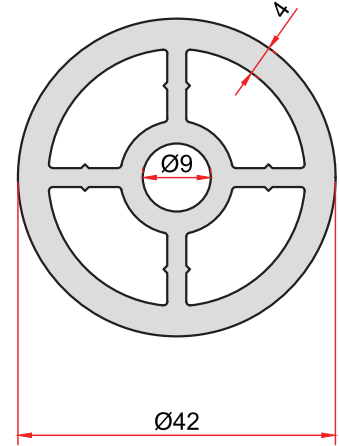

**KOD-CODE** *TEORİK AĞIRLIK*  
**1920** *THEORETICAL WEIGHT*  
**1,857 Kg/m**

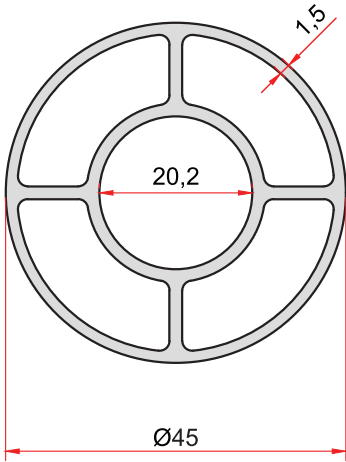

**KOD-CODE** *TEORİK AĞIRLIK*  
**5028** *THEORETICAL WEIGHT*  
**1,053 Kg/m**

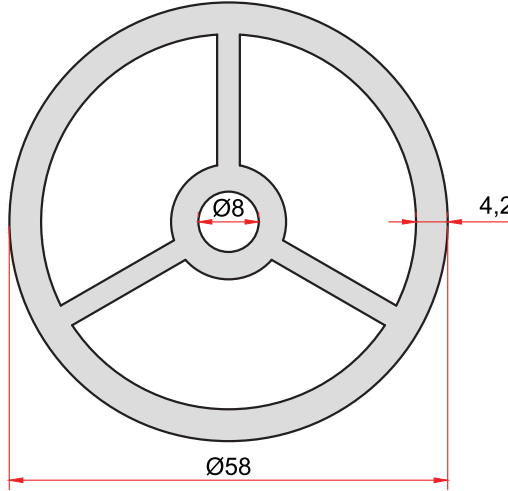

**KOD-CODE** *TEORİK AĞIRLIK*  
**1964** *THEORETICAL WEIGHT*  
**2,692 Kg/m**

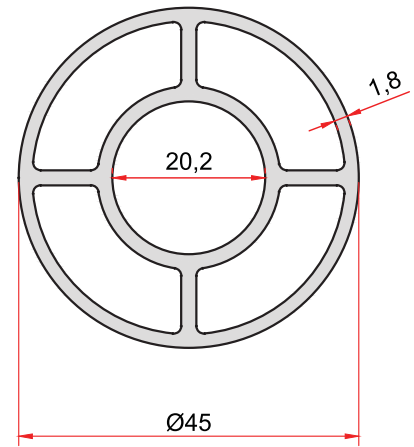

**KOD-CODE** *TEORİK AĞIRLIK*  
**1859** *THEORETICAL WEIGHT*  
**1,231 Kg/m**

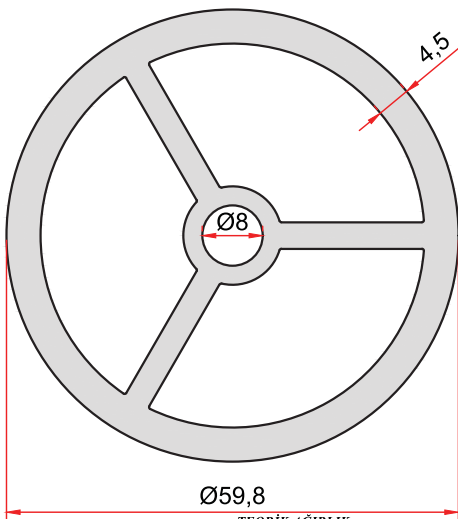

**KOD-CODE** *TEORİK AĞIRLIK*  
**1870** *THEORETICAL WEIGHT*  
**2,870 Kg/m**

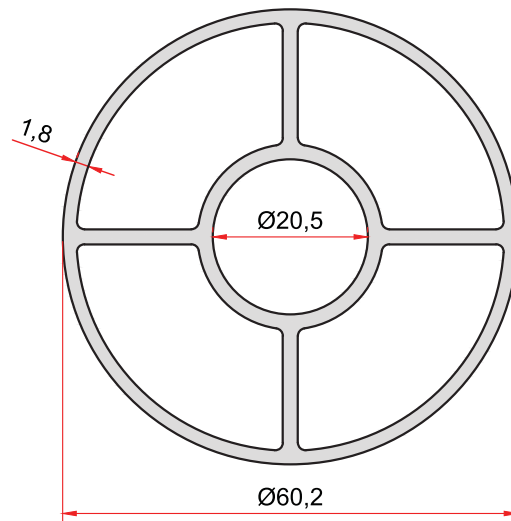

**KOD-CODE** *TEORİK AĞIRLIK*  
**1858** *THEORETICAL WEIGHT*  
**1,628 Kg/m**

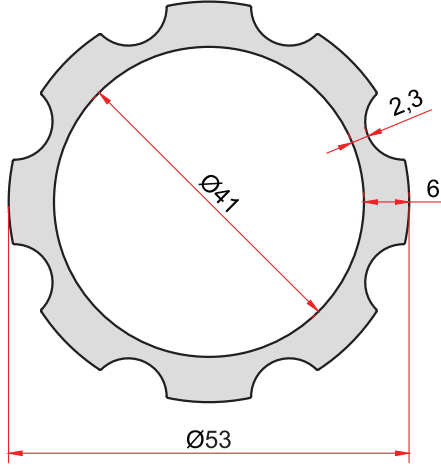

**KOD-CODE** *TEORİK AĞIRLIK*  
*THEORETICAL WEIGHT*  
**1909** **1,845 Kg/m**

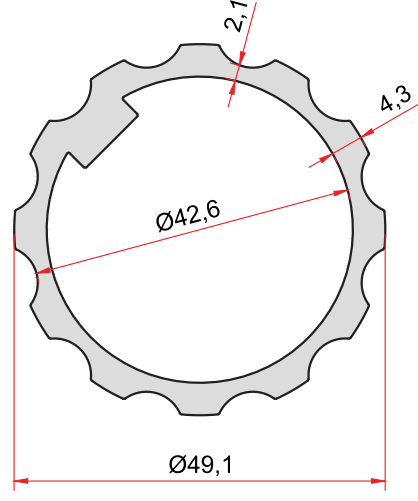

**KOD-CODE** *TEORİK AĞIRLIK*  
*THEORETICAL WEIGHT*  
**1968** **1,350 Kg/m**

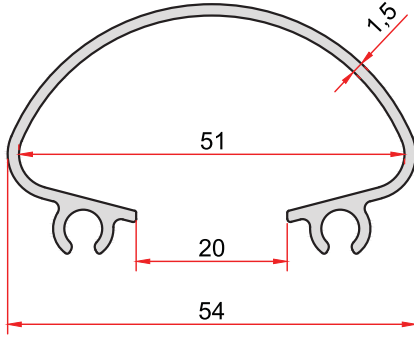

**KOD-CODE** *TEORİK AĞIRLIK*  
*THEORETICAL WEIGHT*  
**5051** **0,548 Kg/m**

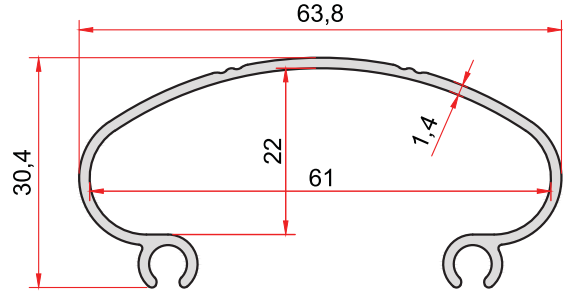

**KOD-CODE** *TEORİK AĞIRLIK*  
*THEORETICAL WEIGHT*  
**5066** **0,505 Kg/m**

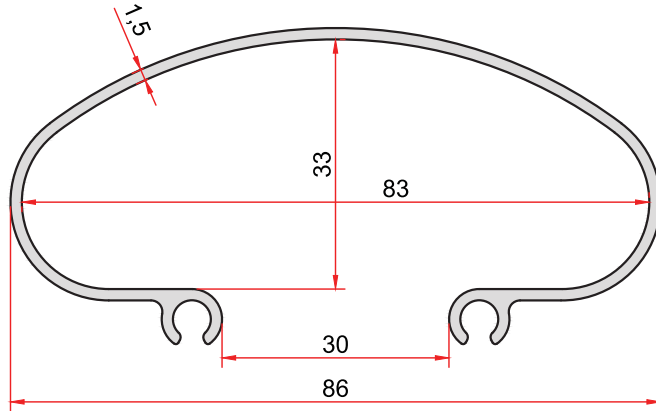

**KOD-CODE** *TEORİK AĞIRLIK*  
*THEORETICAL WEIGHT*  
**5062** **0,785 Kg/m**

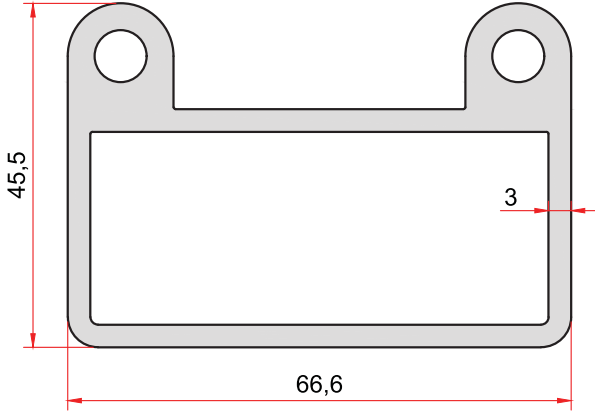

**KOD-CODE** *TEORİK AĞIRLIK*  
*THEORETICAL WEIGHT*  
**1983** **2,217 Kg/m**

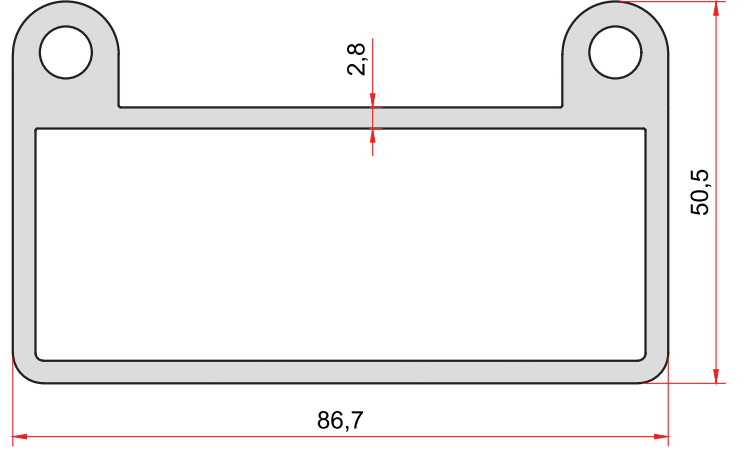

**KOD-CODE** *TEORİK AĞIRLIK*  
*THEORETICAL WEIGHT*  
**1982** **2,578 Kg/m**

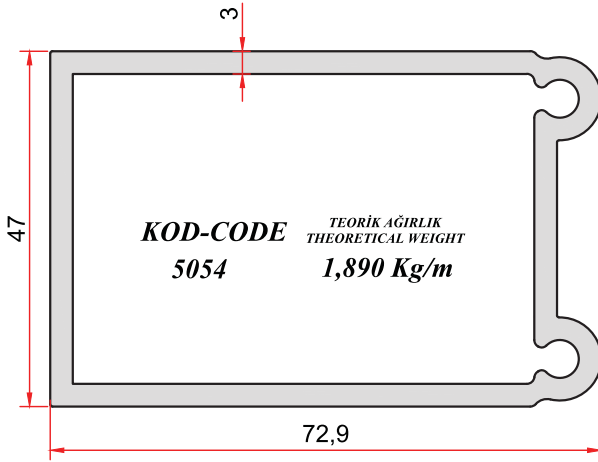

**KOD-CODE** *TEORİK AĞIRLIK*  
*THEORETICAL WEIGHT*  
**5054** **1,890 Kg/m**

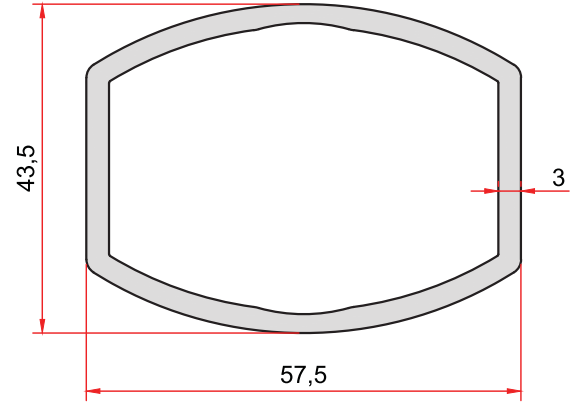

**KOD-CODE** *TEORİK AĞIRLIK*  
*THEORETICAL WEIGHT*  
**5038** **1,306 Kg/m**

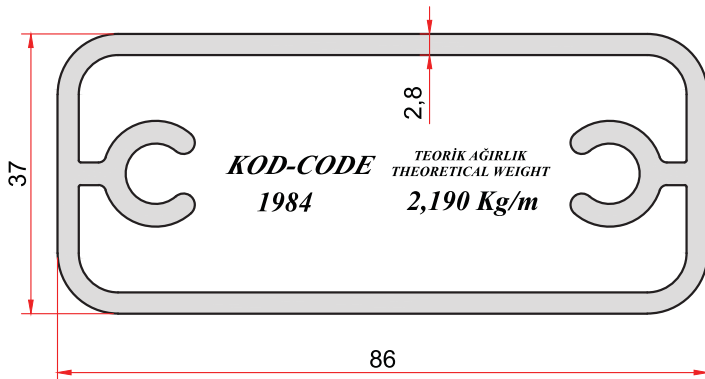

**KOD-CODE** *TEORİK AĞIRLIK*  
*THEORETICAL WEIGHT*  
**1984** **2,190 Kg/m**

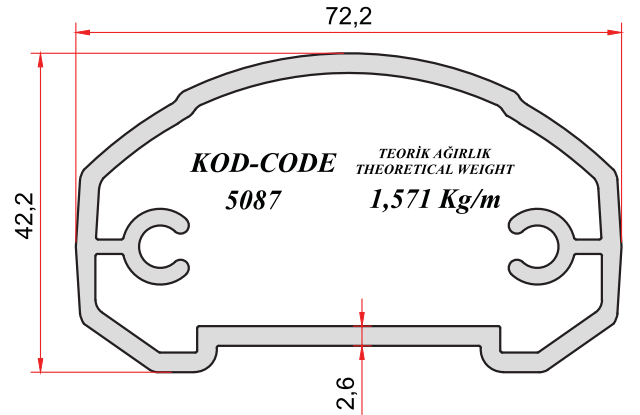

**KOD-CODE** *TEORİK AĞIRLIK*  
*THEORETICAL WEIGHT*  
**5087** **1,571 Kg/m**

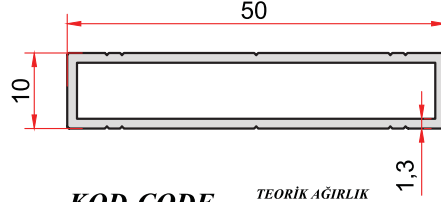

**KOD-CODE** *TEORİK AĞIRLIK*  
*THEORETICAL WEIGHT*  
**5088** **0,400 Kg/m**

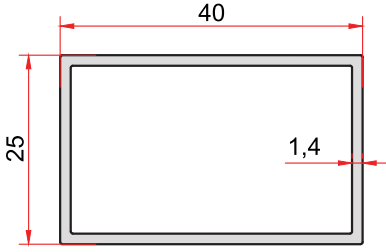

**KOD-CODE** *TEORİK AĞIRLIK*  
*THEORETICAL WEIGHT*  
**5078** **0,470 Kg/m**

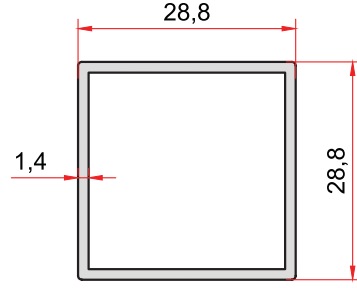

**KOD-CODE** *TEORİK AĞIRLIK*  
*THEORETICAL WEIGHT*  
**5083** **0,413 Kg/m**

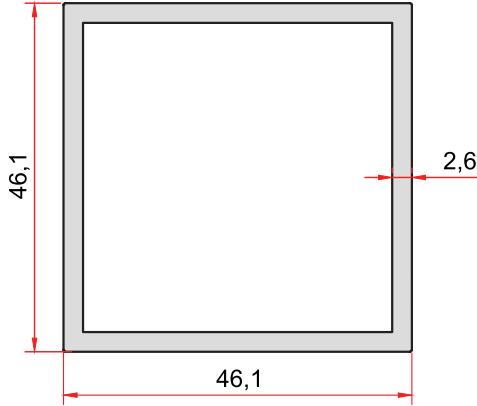

**KOD-CODE** *TEORİK AĞIRLIK*  
*THEORETICAL WEIGHT*  
**1965** **1,220 Kg/m**

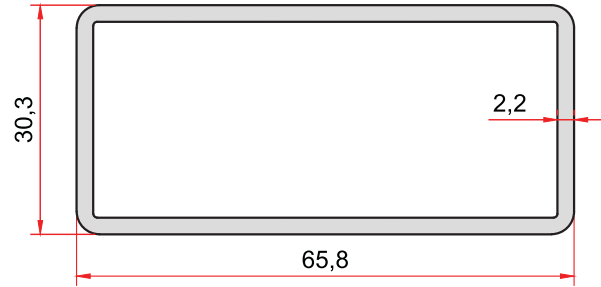

**KOD-CODE** *TEORİK AĞIRLIK*  
*THEORETICAL WEIGHT*  
**1972** **1,069 Kg/m**

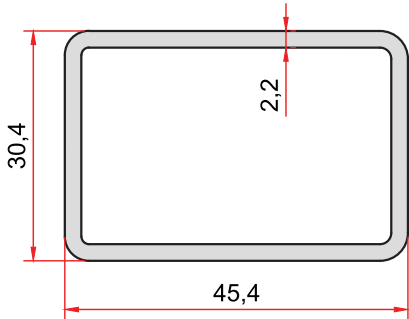

**KOD-CODE** *TEORİK AĞIRLIK*  
*THEORETICAL WEIGHT*  
**5055** **0,823 Kg/m**

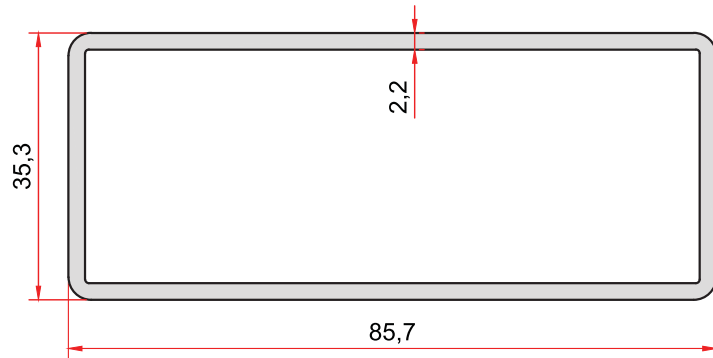

**KOD-CODE** *TEORİK AĞIRLIK*  
*THEORETICAL WEIGHT*  
**1977** **1,364 Kg/m**

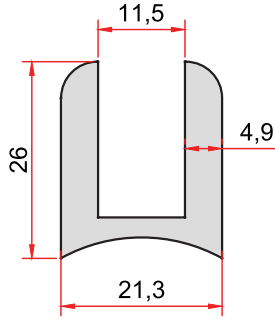

**KOD-CODE** *TEORİK AĞIRLIK*  
**1872** *THEORETICAL WEIGHT*  
**0,721 Kg/m**

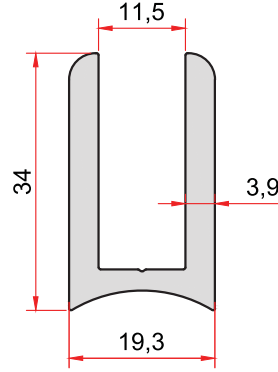

**KOD-CODE** *TEORİK AĞIRLIK*  
**1986** *THEORETICAL WEIGHT*  
**0,780 Kg/m**

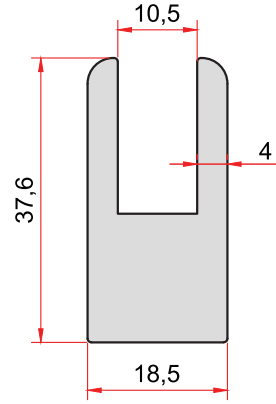

**KOD-CODE** *TEORİK AĞIRLIK*  
**5025** *THEORETICAL WEIGHT*  
**1,280 Kg/m**

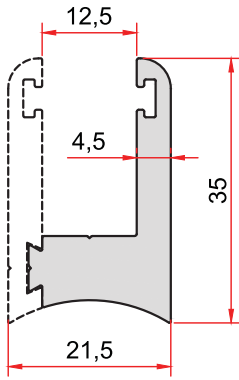

**KOD-CODE** *TEORİK AĞIRLIK*  
**5056** *THEORETICAL WEIGHT*  
**0,697 Kg/m**

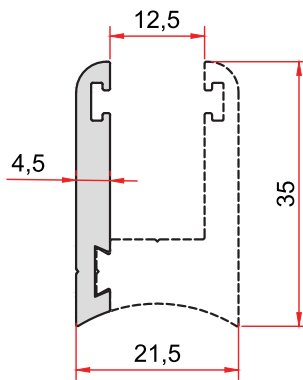

**KOD-CODE** *TEORİK AĞIRLIK*  
**5057** *THEORETICAL WEIGHT*  
**0,342 Kg/m**

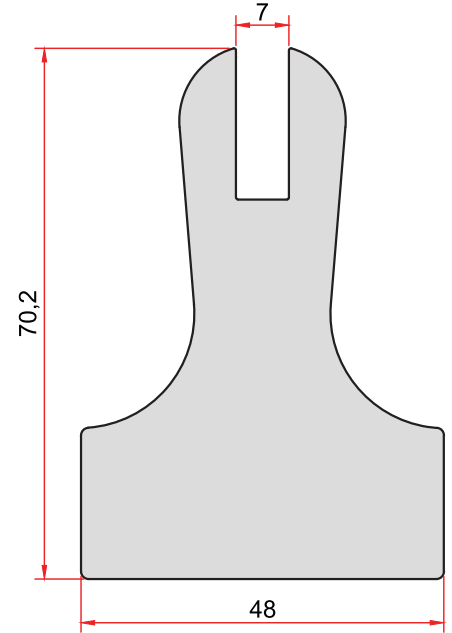

**KOD-CODE** *TEORİK AĞIRLIK*  
**5046** *THEORETICAL WEIGHT*  
**5,054 Kg/m**

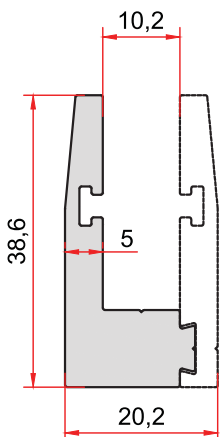

**KOD-CODE** *TEORİK AĞIRLIK*  
**5098** *THEORETICAL WEIGHT*  
**0,769 Kg/m**

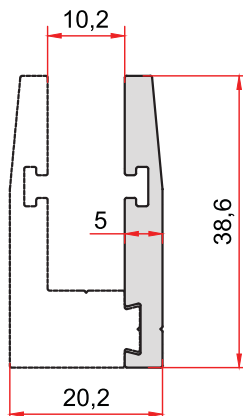

**KOD-CODE** *TEORİK AĞIRLIK*  
**5099** *THEORETICAL WEIGHT*  
**0,421 Kg/m**

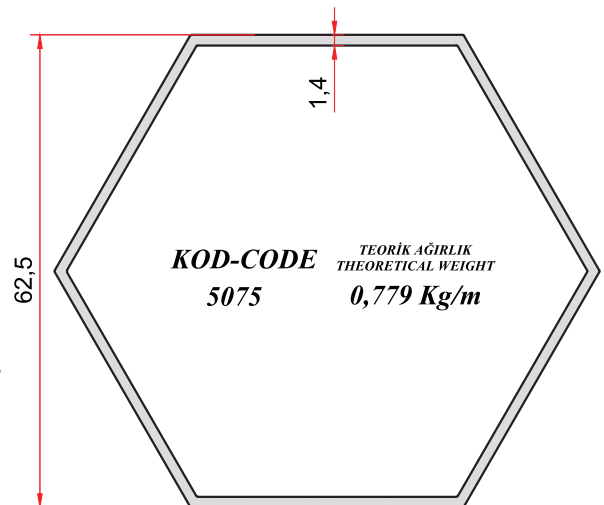

**KOD-CODE** *TEORİK AĞIRLIK*  
**5075** *THEORETICAL WEIGHT*  
**0,779 Kg/m**

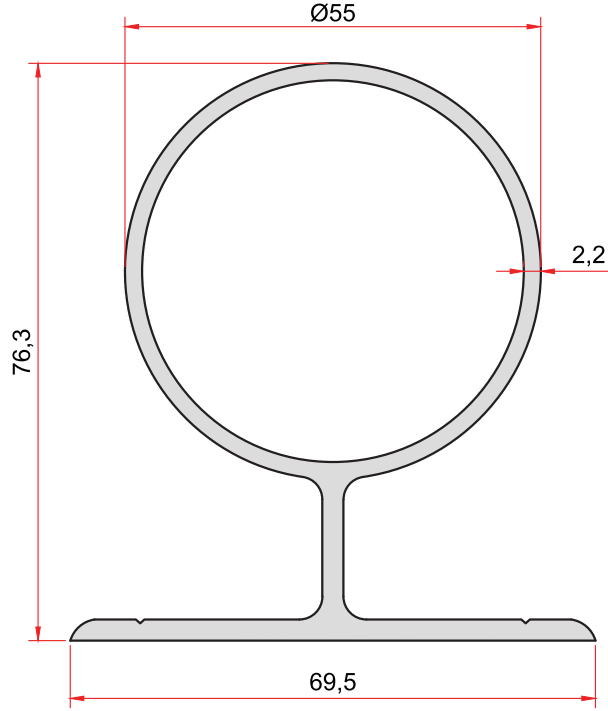

**KOD-CODE** *TEORİK AĞIRLIK*  
*THEORETICAL WEIGHT*  
**1867** **1,674 Kg/m**

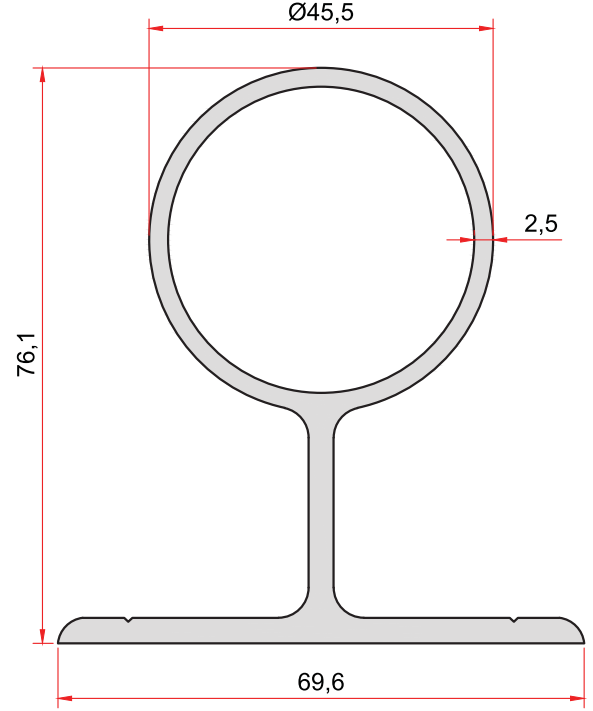

**KOD-CODE** *TEORİK AĞIRLIK*  
*THEORETICAL WEIGHT*  
**1868** **1,798 Kg/m**

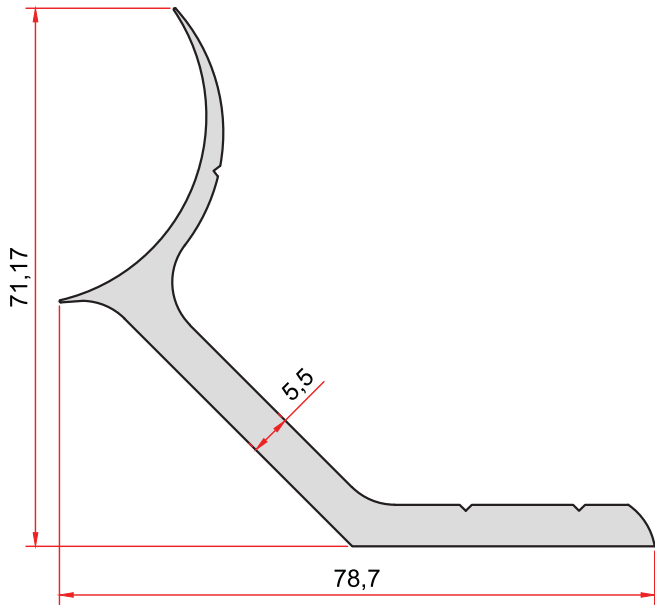

**KOD-CODE** *TEORİK AĞIRLIK*  
*THEORETICAL WEIGHT*  
**1869** **1,528 Kg/m**

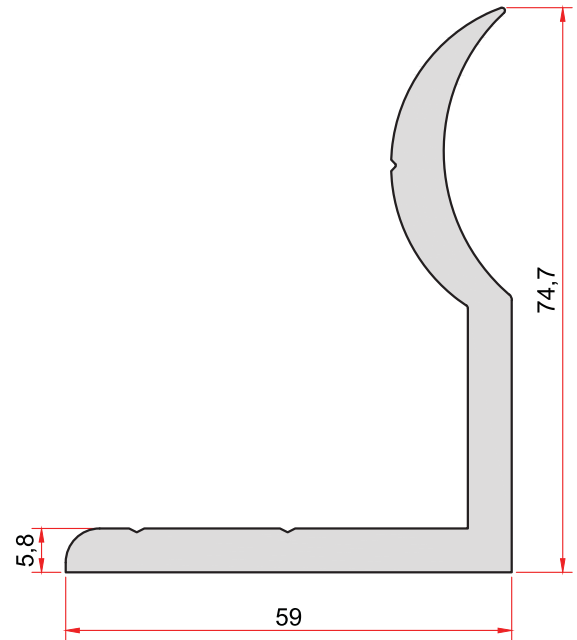

**KOD-CODE** *TEORİK AĞIRLIK*  
*THEORETICAL WEIGHT*  
**1864** **2,047 Kg/m**

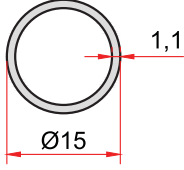

**KOD-CODE** 5026  
**TEORİK AĞIRLIK**  
THEORETICAL WEIGHT  
0,129 Kg/m

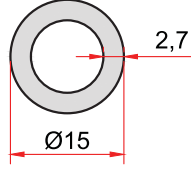

**KOD-CODE** 1932  
**TEORİK AĞIRLIK**  
THEORETICAL WEIGHT  
0,281 Kg/m

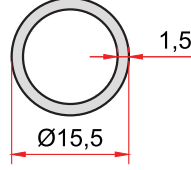

**KOD-CODE** 1922  
**TEORİK AĞIRLIK**  
THEORETICAL WEIGHT  
0,178 Kg/m

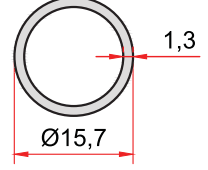

**KOD-CODE** 1988  
**TEORİK AĞIRLIK**  
THEORETICAL WEIGHT  
0,160 Kg/m

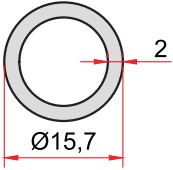

**KOD-CODE** 1893  
**TEORİK AĞIRLIK**  
THEORETICAL WEIGHT  
0,232 Kg/m

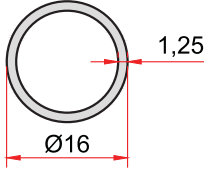

**KOD-CODE** 1916  
**TEORİK AĞIRLIK**  
THEORETICAL WEIGHT  
0,157 Kg/m

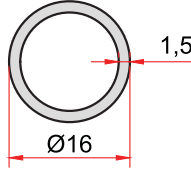

**KOD-CODE** 1885  
**TEORİK AĞIRLIK**  
THEORETICAL WEIGHT  
0,184 Kg/m

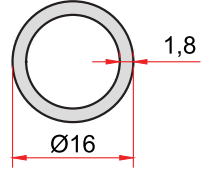

**KOD-CODE** 1883  
**TEORİK AĞIRLIK**  
THEORETICAL WEIGHT  
0,216 Kg/m

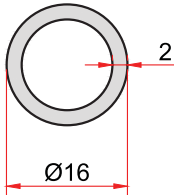

**KOD-CODE** 1943  
**TEORİK AĞIRLIK**  
THEORETICAL WEIGHT  
0,238 Kg/m

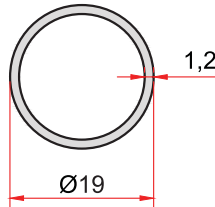

**KOD-CODE** 1880  
**TEORİK AĞIRLIK**  
THEORETICAL WEIGHT  
0,181 Kg/m

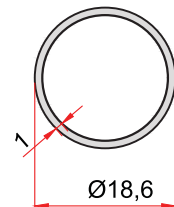

**KOD-CODE** 5076  
**TEORİK AĞIRLIK**  
THEORETICAL WEIGHT  
0,149 Kg/m

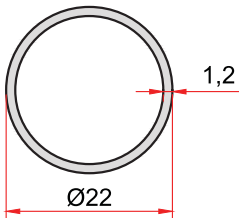

**KOD-CODE** 1987  
**TEORİK AĞIRLIK**  
THEORETICAL WEIGHT  
0,211 Kg/m

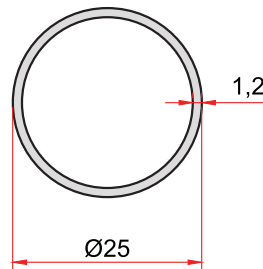

**KOD-CODE** 5035  
**TEORİK AĞIRLIK**  
THEORETICAL WEIGHT  
0,243 Kg/m

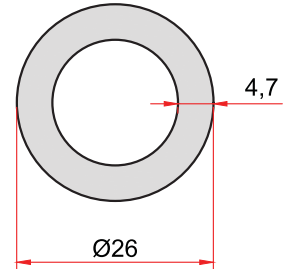

**KOD-CODE** 1952  
**TEORİK AĞIRLIK**  
THEORETICAL WEIGHT  
0,851 Kg/m



# Küpeşte Profilleri

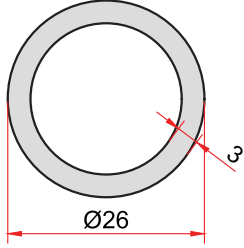

**KOD-CODE** TEORİK AĞIRLIK  
5084 THEORETICAL WEIGHT  
0,583 Kg/m

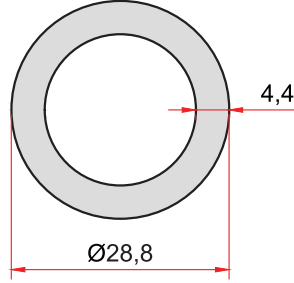

**KOD-CODE** TEORİK AĞIRLIK  
1894 THEORETICAL WEIGHT  
0,910 Kg/m

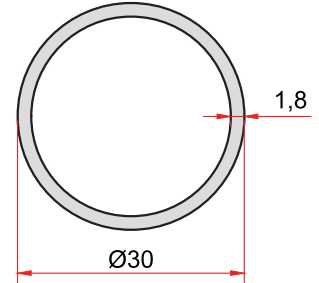

**KOD-CODE** TEORİK AĞIRLIK  
1911 THEORETICAL WEIGHT  
0,429 Kg/m

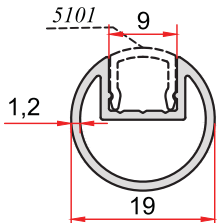

**KOD-CODE** TEORİK AĞIRLIK  
5101 THEORETICAL WEIGHT  
0,218 Kg/m

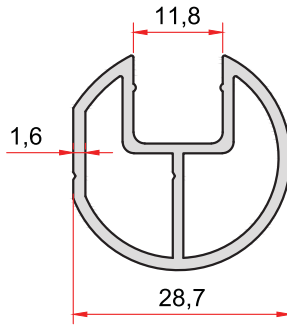

**KOD-CODE** TEORİK AĞIRLIK  
1919 THEORETICAL WEIGHT  
0,510 Kg/m

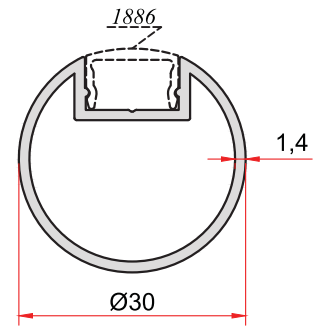

**KOD-CODE** TEORİK AĞIRLIK  
1991 THEORETICAL WEIGHT  
0,391 Kg/m

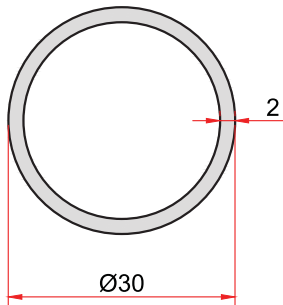

**KOD-CODE** TEORİK AĞIRLIK  
1993 THEORETICAL WEIGHT  
0,475 Kg/m

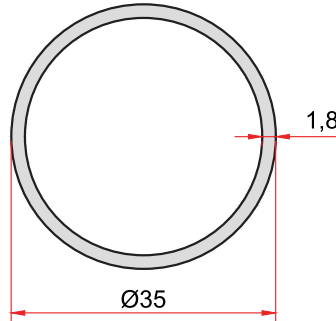

**KOD-CODE** TEORİK AĞIRLIK  
1897 THEORETICAL WEIGHT  
0,508 Kg/m

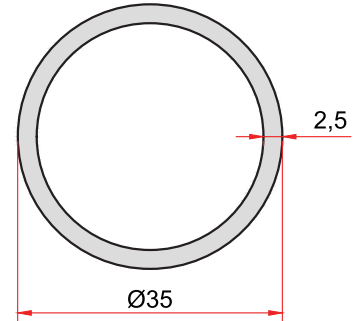

**KOD-CODE** TEORİK AĞIRLIK  
1882 THEORETICAL WEIGHT  
0,688 Kg/m

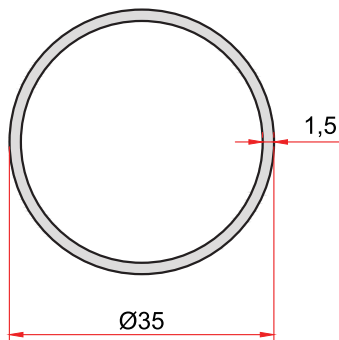

**KOD-CODE** TEORİK AĞIRLIK  
5036 THEORETICAL WEIGHT  
0,426 Kg/m

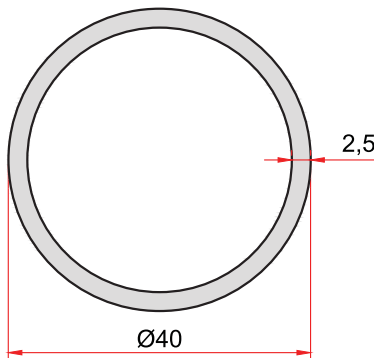

**KOD-CODE** TEORİK AĞIRLIK  
1900 THEORETICAL WEIGHT  
0,793 Kg/m

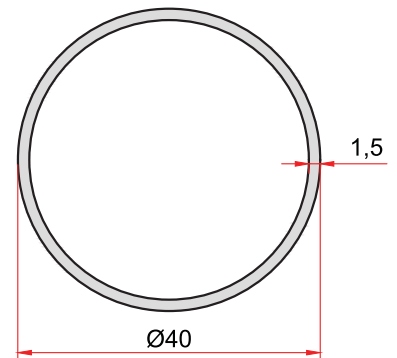

**KOD-CODE** TEORİK AĞIRLIK  
1910 THEORETICAL WEIGHT  
0,489 Kg/m

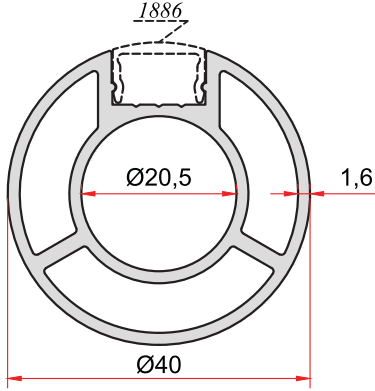

**KOD-CODE** TEORİK AĞIRLIK  
1888 THEORETICAL WEIGHT  
0,934 Kg/m

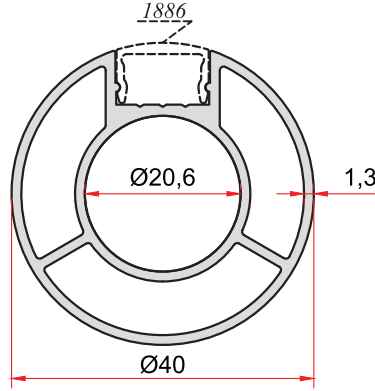

**KOD-CODE** TEORİK AĞIRLIK  
1889 THEORETICAL WEIGHT  
0,761 Kg/m

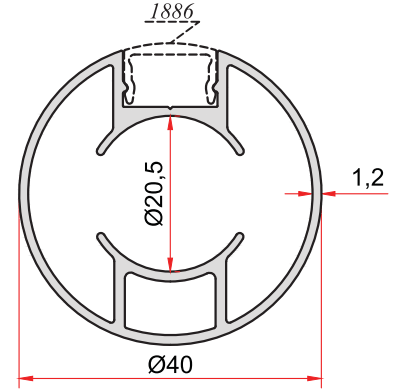

**KOD-CODE** TEORİK AĞIRLIK  
1890 THEORETICAL WEIGHT  
0,645 Kg/m

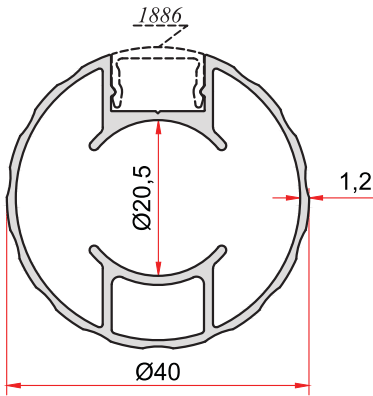

**KOD-CODE** TEORİK AĞIRLIK  
1904 THEORETICAL WEIGHT  
0,580 Kg/m

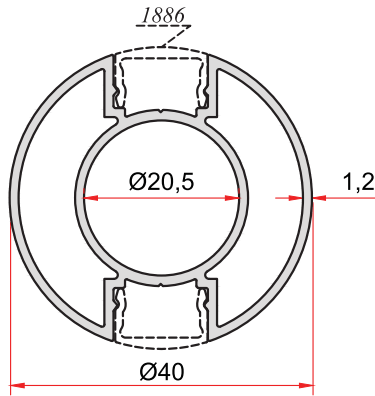

**KOD-CODE** TEORİK AĞIRLIK  
1915 THEORETICAL WEIGHT  
0,669 Kg/m

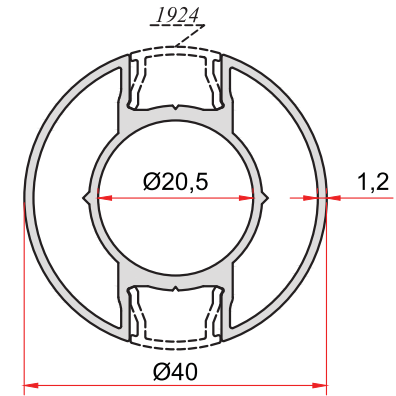

**KOD-CODE** TEORİK AĞIRLIK  
1925 THEORETICAL WEIGHT  
0,721 Kg/m

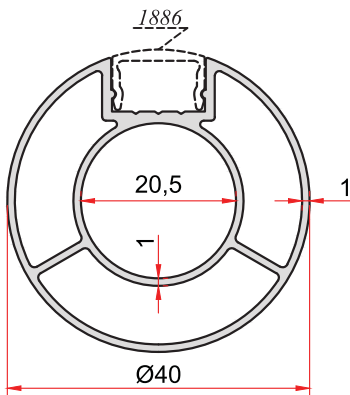

**KOD-CODE** TEORİK AĞIRLIK  
2000 THEORETICAL WEIGHT  
0,607 Kg/m

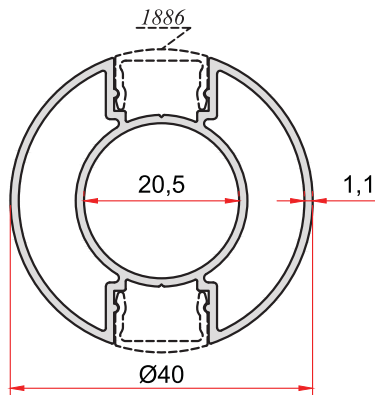

**KOD-CODE** TEORİK AĞIRLIK  
5012 THEORETICAL WEIGHT  
0,600 Kg/m

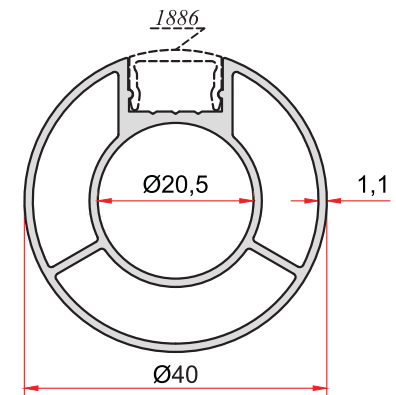

**KOD-CODE** TEORİK AĞIRLIK  
1931 THEORETICAL WEIGHT  
0,672 Kg/m

# Küpeşte Profilleri

**ARFEM**<sup>®</sup>  
ALÜMİNYUM

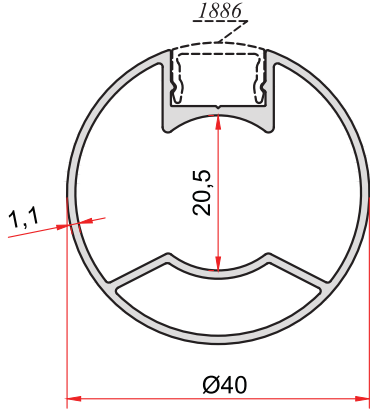

**KOD-CODE** *TEORİK AĞIRLIK*  
*THEORETICAL WEIGHT*  
**5072** **0,543 Kg/m**

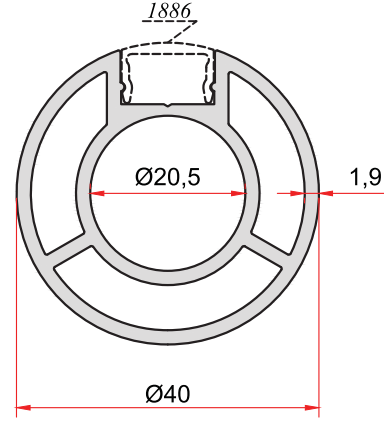

**KOD-CODE** *TEORİK AĞIRLIK*  
*THEORETICAL WEIGHT*  
**1990** **1,047 Kg/m**

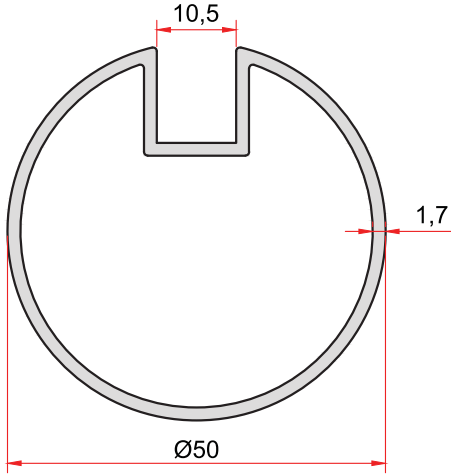

**KOD-CODE** *TEORİK AĞIRLIK*  
*THEORETICAL WEIGHT*  
**1929** **0,810 Kg/m**

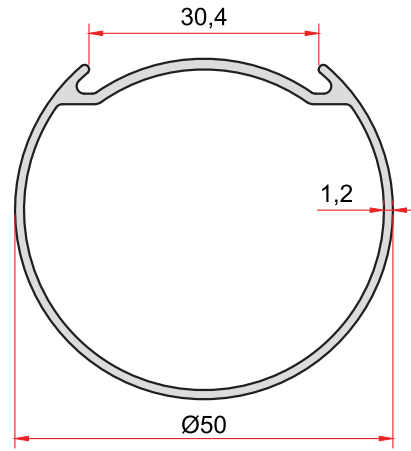

**KOD-CODE** *TEORİK AĞIRLIK*  
*THEORETICAL WEIGHT*  
**5030** **0,543 Kg/m**

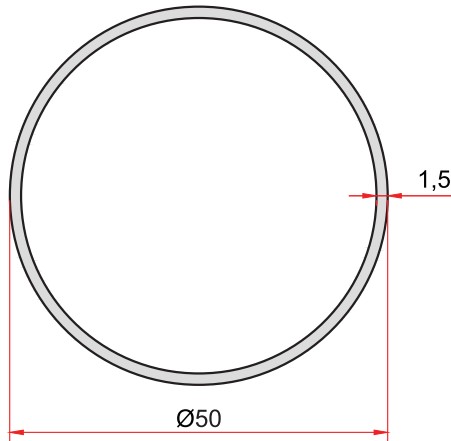

**KOD-CODE** *TEORİK AĞIRLIK*  
*THEORETICAL WEIGHT*  
**1884** **0,618 Kg/m**

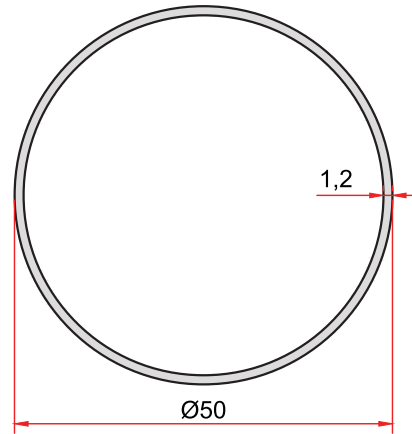

**KOD-CODE** *TEORİK AĞIRLIK*  
*THEORETICAL WEIGHT*  
**5059** **0,496 Kg/m**

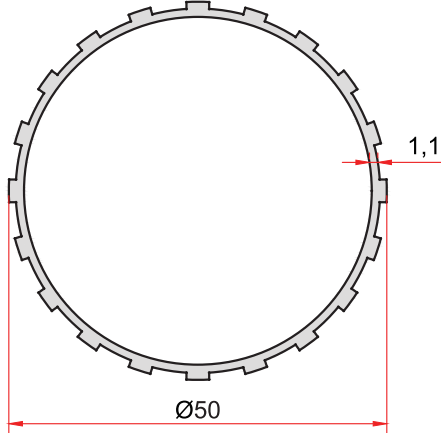

**KOD-CODE** *TEORİK AĞIRLIK*  
*THEORETICAL WEIGHT*  
**1901** **0,586 Kg/m**

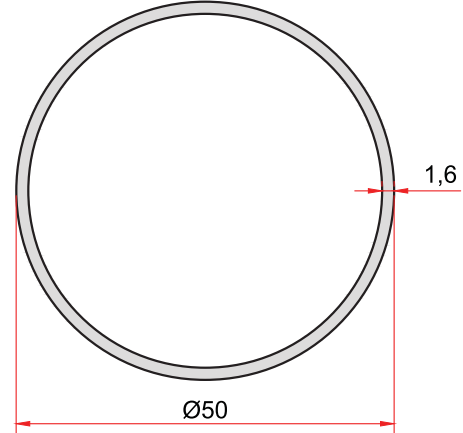

**KOD-CODE** *TEORİK AĞIRLIK*  
*THEORETICAL WEIGHT*  
**1912** **0,656 Kg/m**

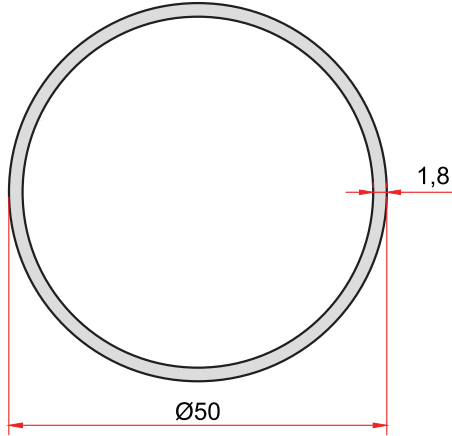

**KOD-CODE** *TEORİK AĞIRLIK*  
*THEORETICAL WEIGHT*  
**1921** **0,737 Kg/m**

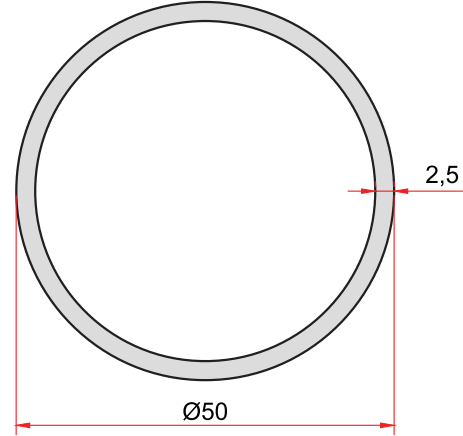

**KOD-CODE** *TEORİK AĞIRLIK*  
*THEORETICAL WEIGHT*  
**1923** **1,007 Kg/m**

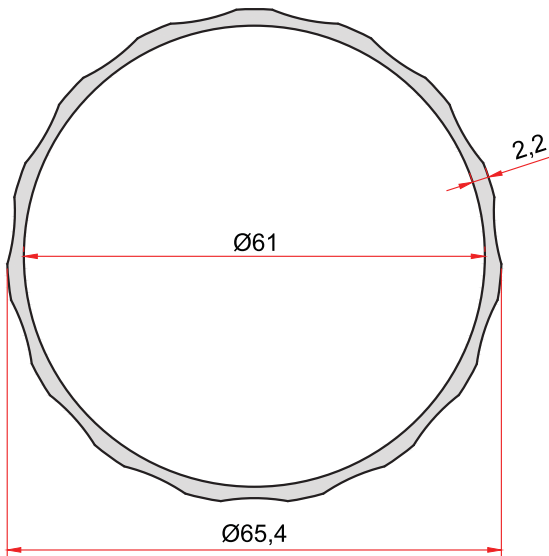

**KOD-CODE** *TEORİK AĞIRLIK*  
*THEORETICAL WEIGHT*  
**1963** **1,011 Kg/m**

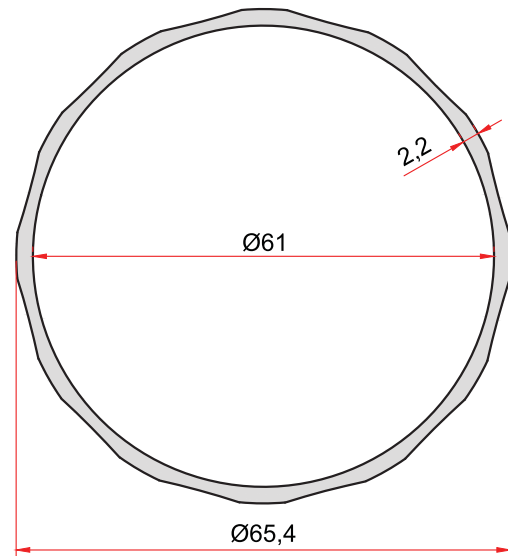

**KOD-CODE** *TEORİK AĞIRLIK*  
*THEORETICAL WEIGHT*  
**1887** **1,037 Kg/m**

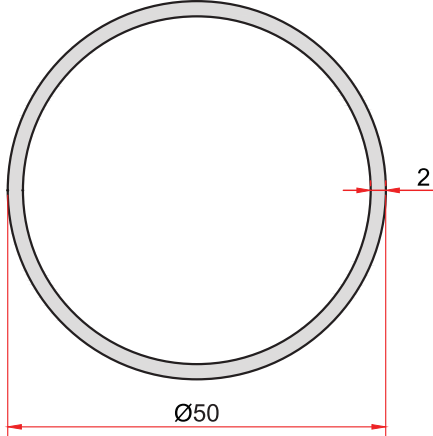

**KOD-CODE** *TEORİK AĞIRLIK*  
*THEORETICAL WEIGHT*  
**1881** **0,815 Kg/m**

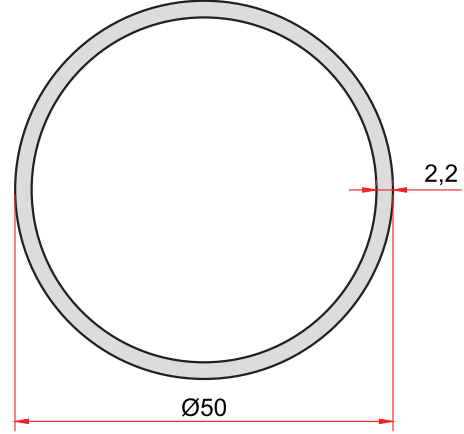

**KOD-CODE** *TEORİK AĞIRLIK*  
*THEORETICAL WEIGHT*  
**1926** **0,891 Kg/m**

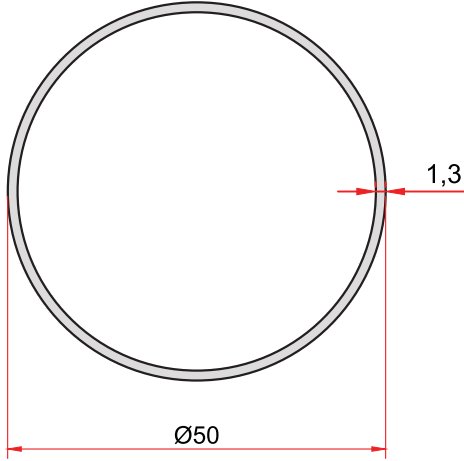

**KOD-CODE** *TEORİK AĞIRLIK*  
*THEORETICAL WEIGHT*  
**1957** **0,537 Kg/m**

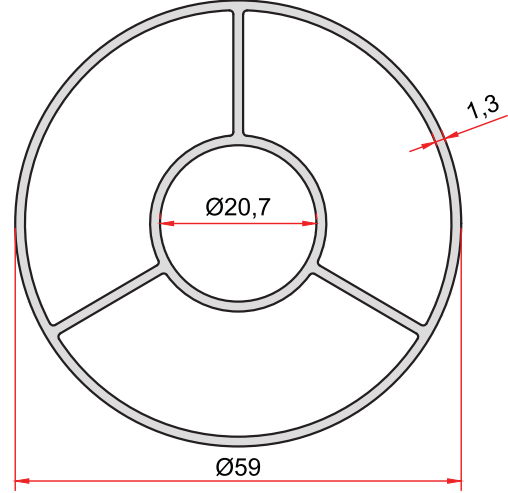

**KOD-CODE** *TEORİK AĞIRLIK*  
*THEORETICAL WEIGHT*  
**1939** **1,055 Kg/m**

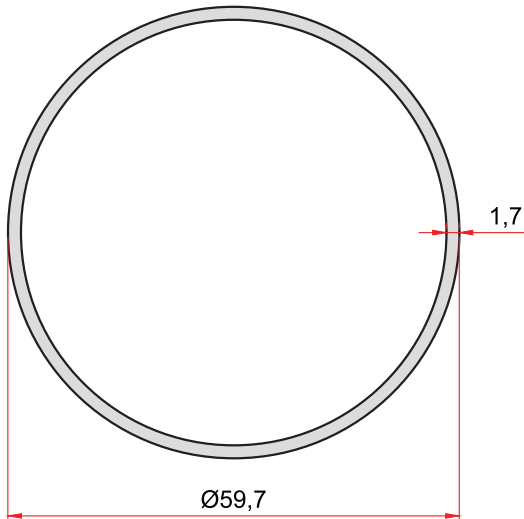

**KOD-CODE** *TEORİK AĞIRLIK*  
*THEORETICAL WEIGHT*  
**1902** **0,837 Kg/m**

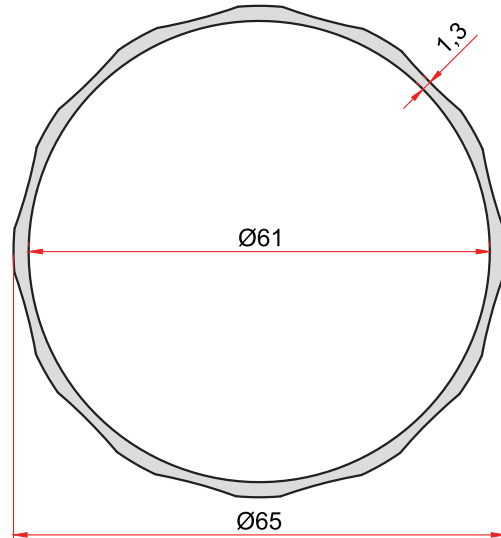

**KOD-CODE** *TEORİK AĞIRLIK*  
*THEORETICAL WEIGHT*  
**1917** **0,902 Kg/m**

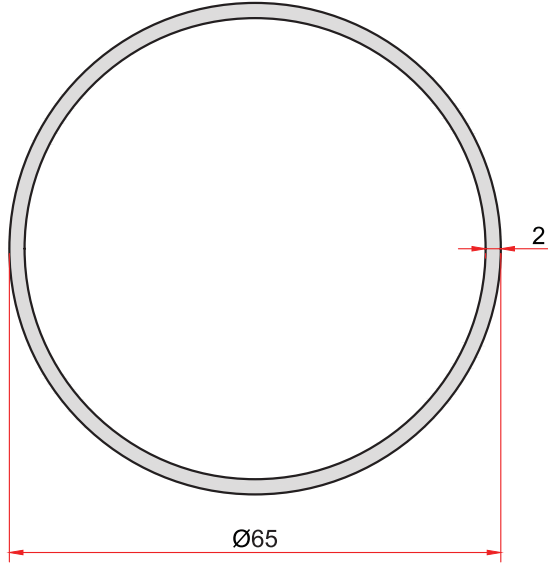

**KOD-CODE** *TEORİK AĞIRLIK*  
*THEORETICAL WEIGHT*  
**1913** **1,069 Kg/m**

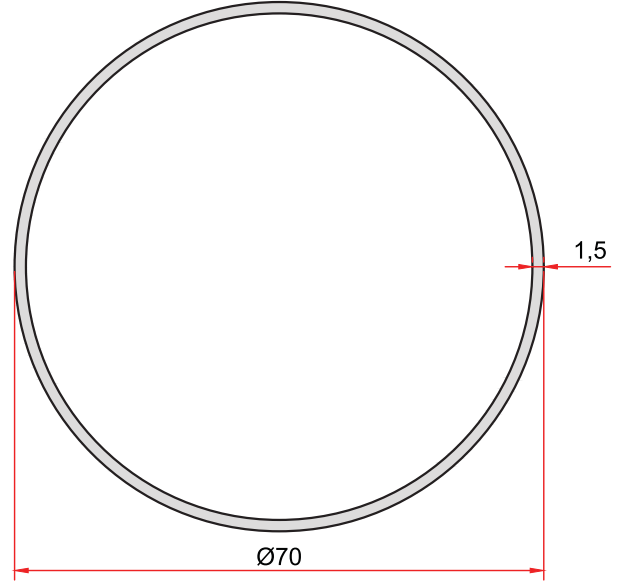

**KOD-CODE** *TEORİK AĞIRLIK*  
*THEORETICAL WEIGHT*  
**5050** **0,872 Kg/m**

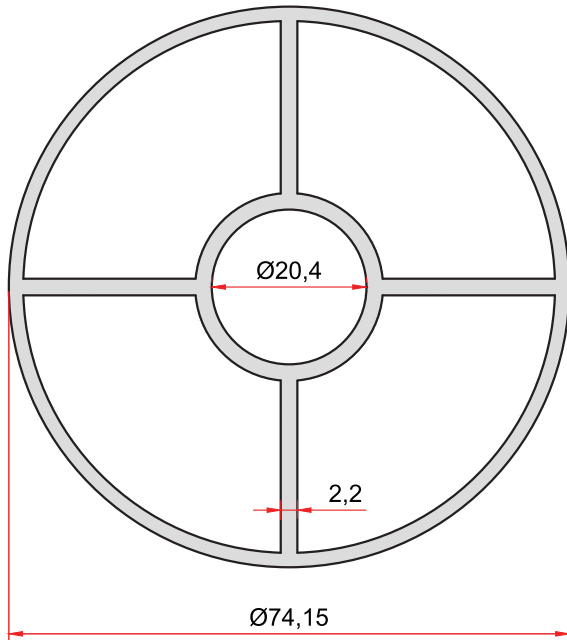

**KOD-CODE** *TEORİK AĞIRLIK*  
*THEORETICAL WEIGHT*  
**1958** **2,127 Kg/m**

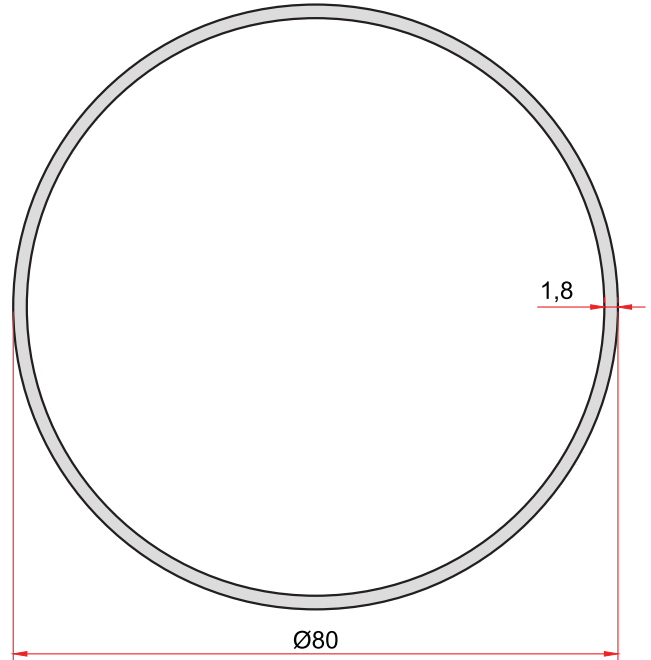

**KOD-CODE** *TEORİK AĞIRLIK*  
*THEORETICAL WEIGHT*  
**1936** **1,193 Kg/m**

# Küpeşte Profilleri

**ARFEM**<sup>®</sup>  
ALÜMİNYUM

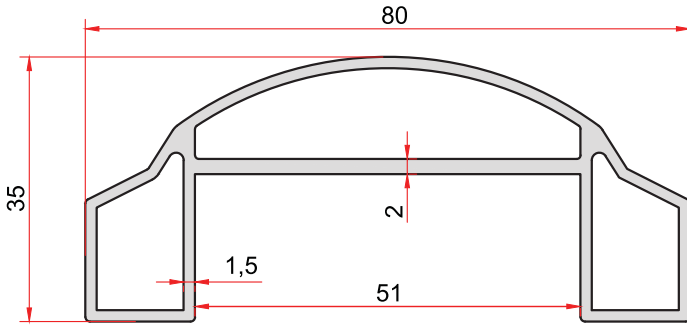

**KOD-CODE** *TEORİK AĞIRLIK*  
*THEORETICAL WEIGHT*  
**148** **1,075 Kg/m**

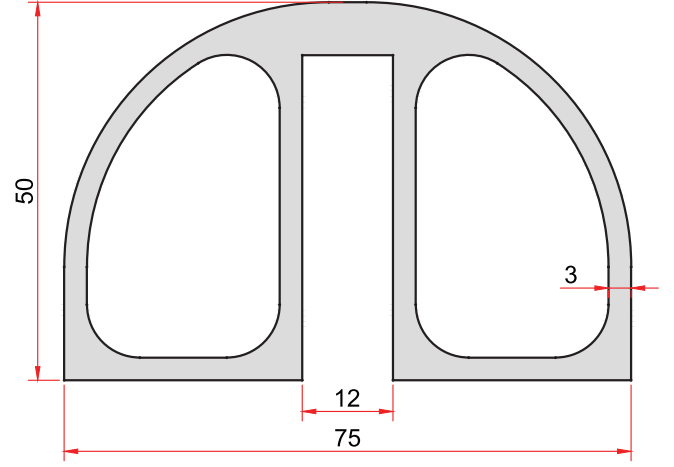

**KOD-CODE** *TEORİK AĞIRLIK*  
*THEORETICAL WEIGHT*  
**1878** **2,695 Kg/m**

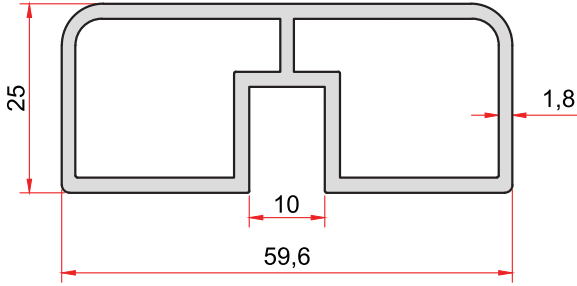

**KOD-CODE** *TEORİK AĞIRLIK*  
*THEORETICAL WEIGHT*  
**1876** **1,010 Kg/m**

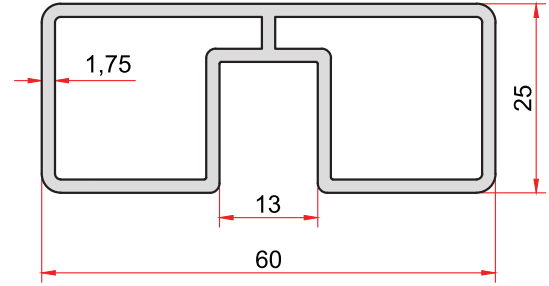

**KOD-CODE** *TEORİK AĞIRLIK*  
*THEORETICAL WEIGHT*  
**1997** **0,937 Kg/m**

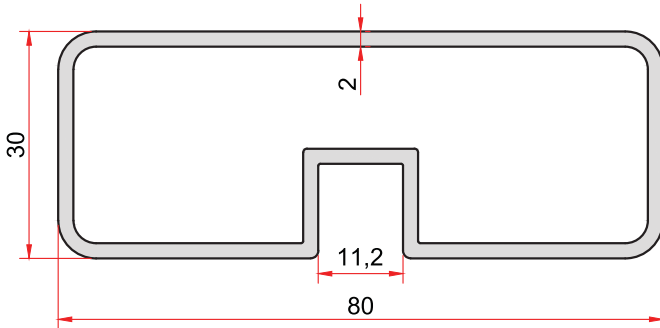

**KOD-CODE** *TEORİK AĞIRLIK*  
*THEORETICAL WEIGHT*  
**1954** **1,242 Kg/m**

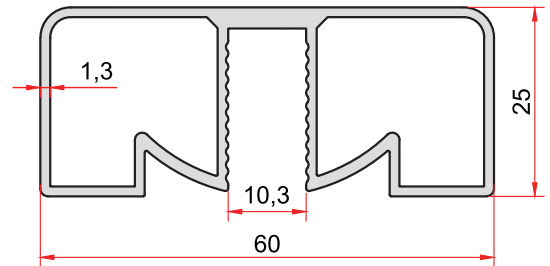

**KOD-CODE** *TEORİK AĞIRLIK*  
*THEORETICAL WEIGHT*  
**1903** **0,804 Kg/m**

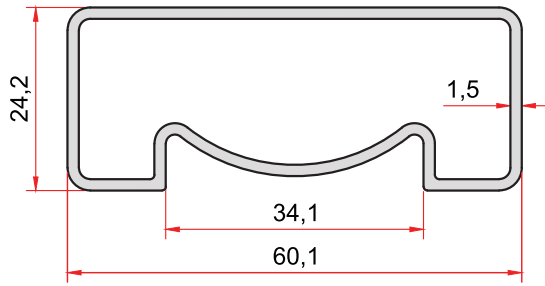

**KOD-CODE** *TEORİK AĞIRLIK*  
**1874** *THEORETICAL WEIGHT*  
**0,707 Kg/m**

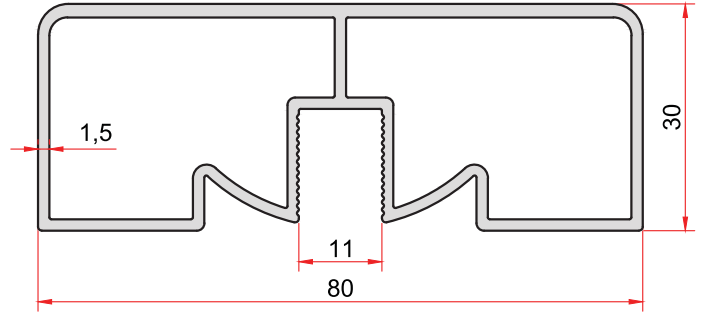

**KOD-CODE** *TEORİK AĞIRLIK*  
**1891** *THEORETICAL WEIGHT*  
**1,137 Kg/m**

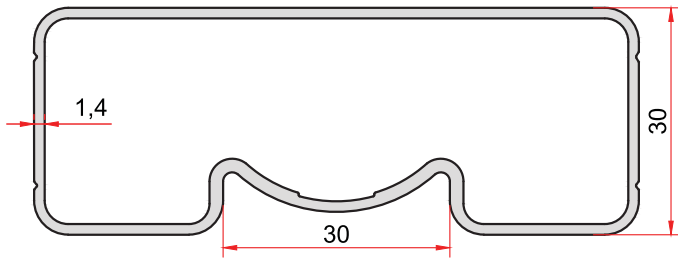

**KOD-CODE** *TEORİK AĞIRLIK*  
**5034** *THEORETICAL WEIGHT*  
**0,877 Kg/m**

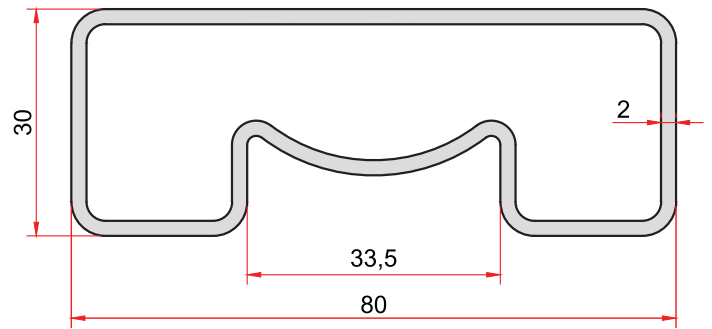

**KOD-CODE** *TEORİK AĞIRLIK*  
**1927** *THEORETICAL WEIGHT*  
**1,242 Kg/m**

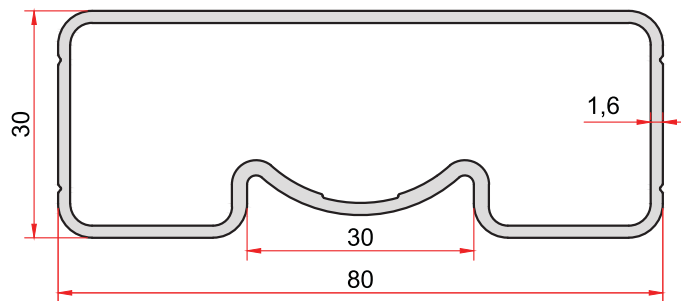

**KOD-CODE** *TEORİK AĞIRLIK*  
**1976** *THEORETICAL WEIGHT*  
**0,995 Kg/m**



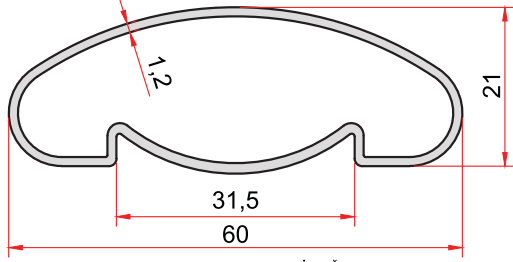

**KOD-CODE** *TEORİK AĞIRLIK*  
*THEORETICAL WEIGHT*  
**5033** **0,489 Kg/m**

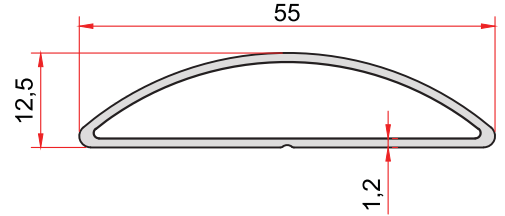

**KOD-CODE** *TEORİK AĞIRLIK*  
*THEORETICAL WEIGHT*  
**5069** **0,372 Kg/m**

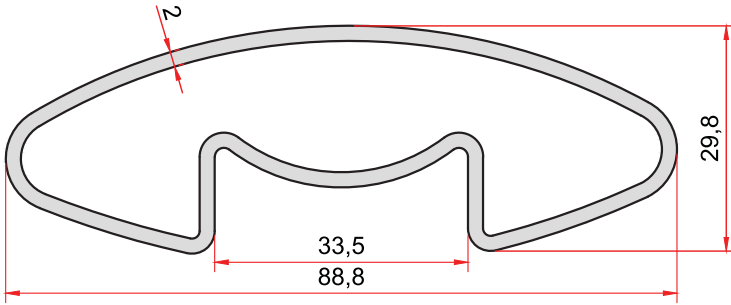

**KOD-CODE** *TEORİK AĞIRLIK*  
*THEORETICAL WEIGHT*  
**1928** **1,188 Kg/m**

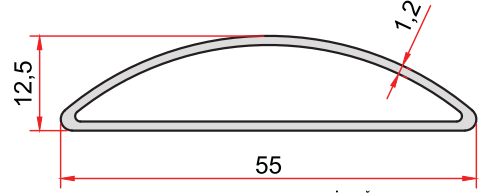

**KOD-CODE** *TEORİK AĞIRLIK*  
*THEORETICAL WEIGHT*  
**5058** **0,371 Kg/m**

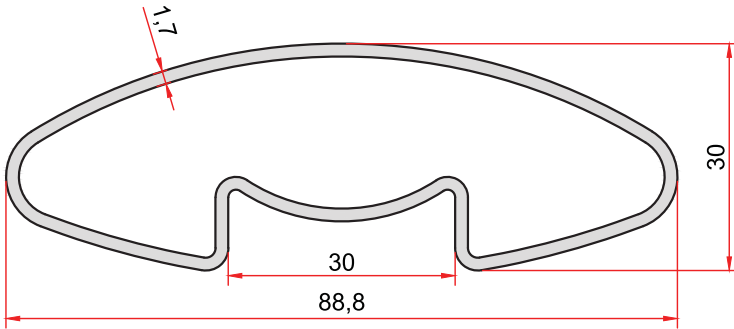

**KOD-CODE** *TEORİK AĞIRLIK*  
*THEORETICAL WEIGHT*  
**5041** **0,977 Kg/m**

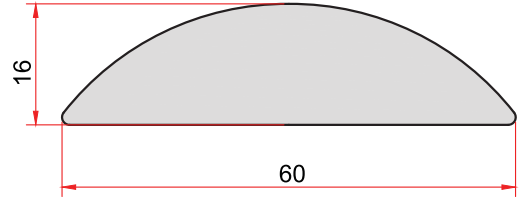

**KOD-CODE** *TEORİK AĞIRLIK*  
*THEORETICAL WEIGHT*  
**5081** **1,879 Kg/m**

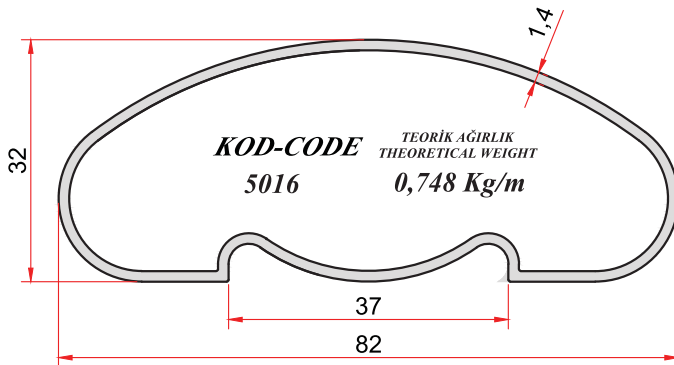

**KOD-CODE** *TEORİK AĞIRLIK*  
*THEORETICAL WEIGHT*  
**5016** **0,748 Kg/m**

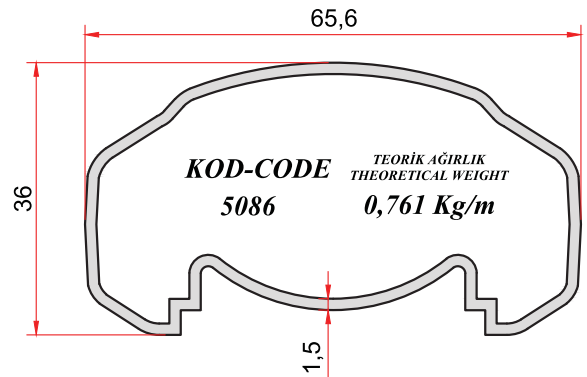

**KOD-CODE** *TEORİK AĞIRLIK*  
*THEORETICAL WEIGHT*  
**5086** **0,761 Kg/m**

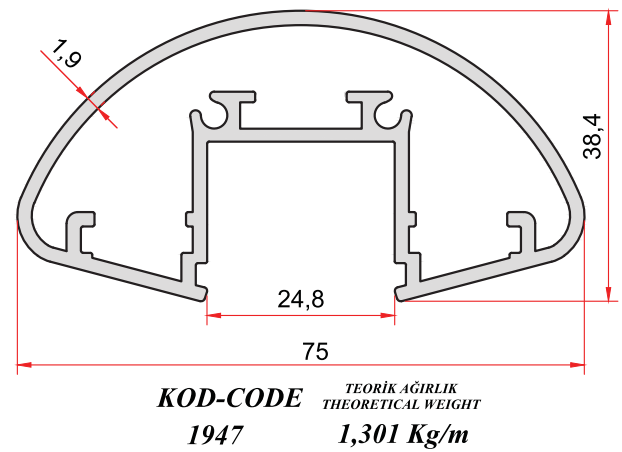
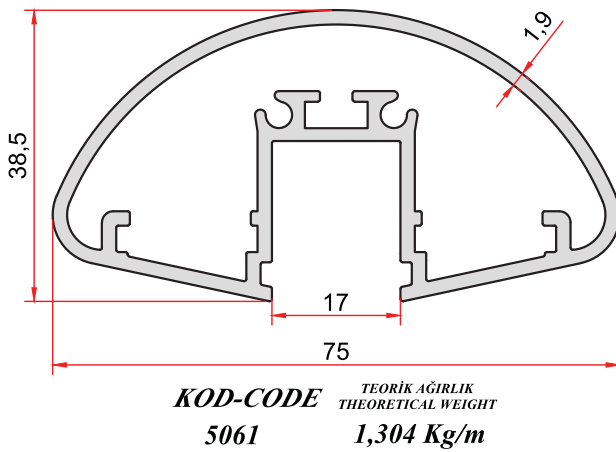
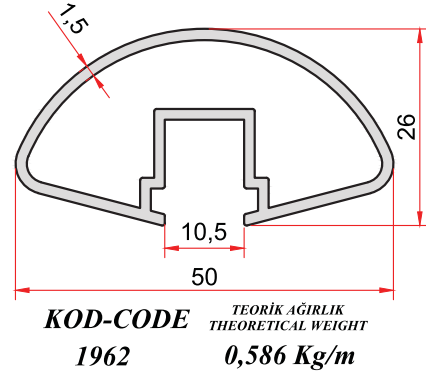
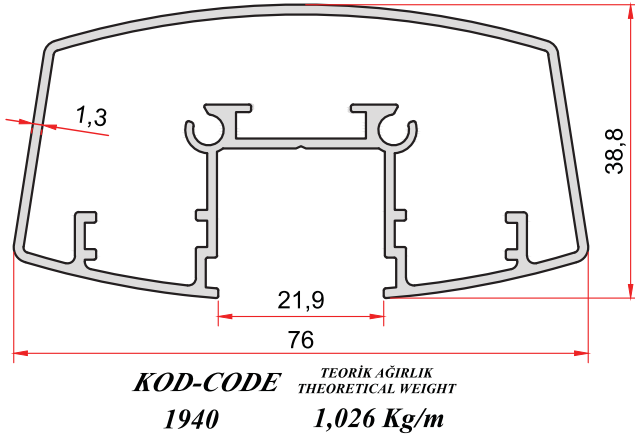
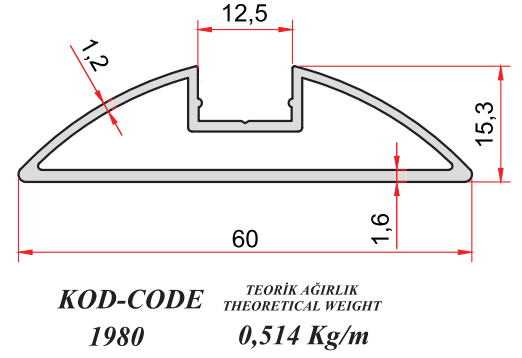
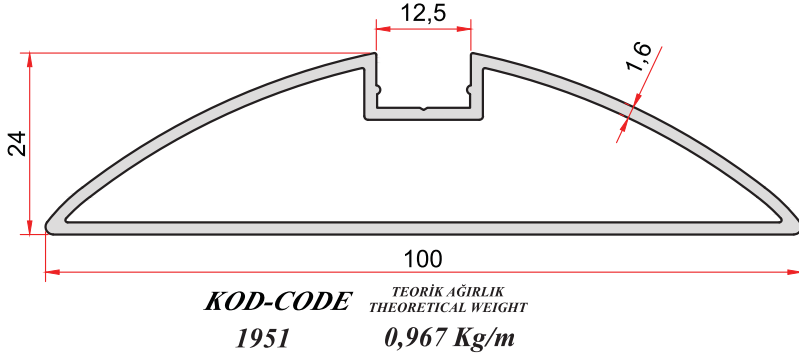

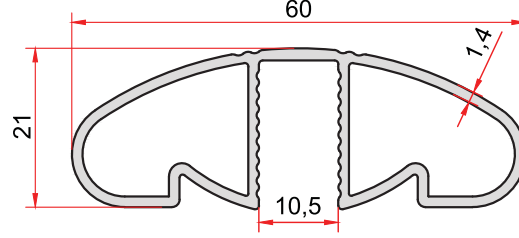

**KOD-CODE** *TEORİK AĞIRLIK*  
*THEORETICAL WEIGHT*  
**5067** **0,629 Kg/m**

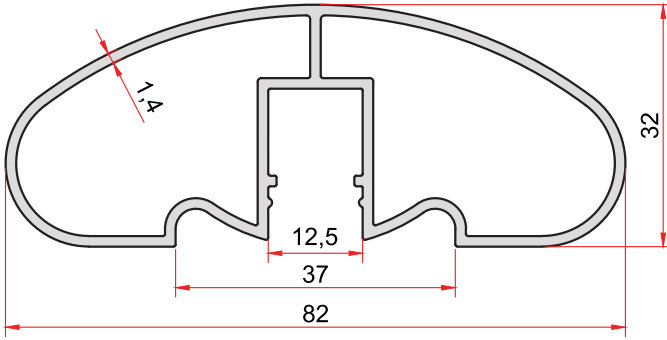

**KOD-CODE** *TEORİK AĞIRLIK*  
*THEORETICAL WEIGHT*  
**1998** **0,939 Kg/m**

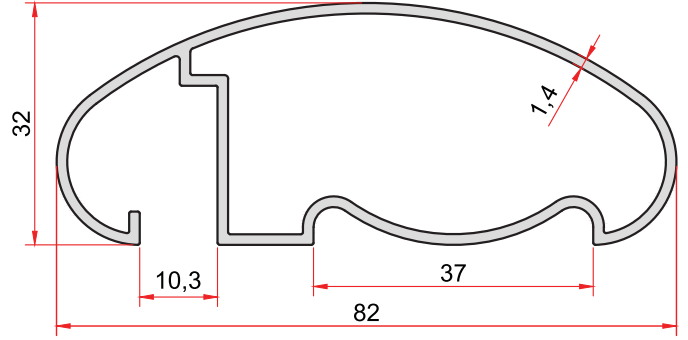

**KOD-CODE** *TEORİK AĞIRLIK*  
*THEORETICAL WEIGHT*  
**1999** **0,832 Kg/m**

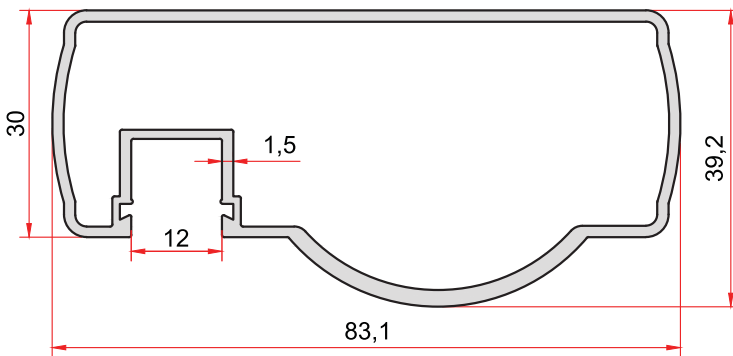

**KOD-CODE** *TEORİK AĞIRLIK*  
*THEORETICAL WEIGHT*  
**1907** **1,053 Kg/m**

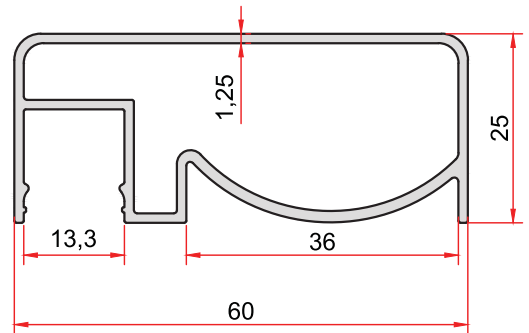

**KOD-CODE** *TEORİK AĞIRLIK*  
*THEORETICAL WEIGHT*  
**1961** **0,675 Kg/m**

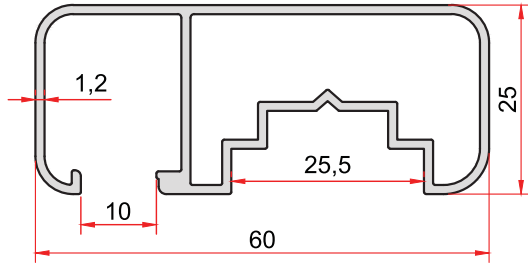

**KOD-CODE** *TEORİK AĞIRLIK*  
**5042** *THEORETICAL WEIGHT*  
**0,645 Kg/m**

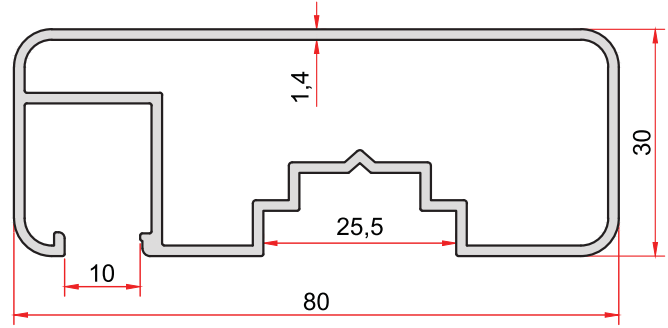

**KOD-CODE** *TEORİK AĞIRLIK*  
**5043** *THEORETICAL WEIGHT*  
**0,980 Kg/m**

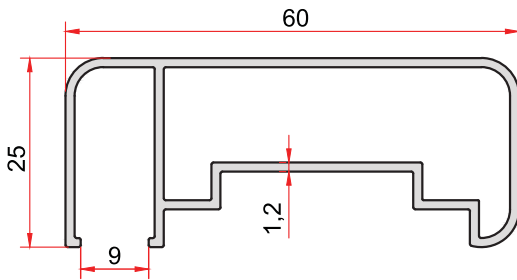

**KOD-CODE** *TEORİK AĞIRLIK*  
**5079** *THEORETICAL WEIGHT*  
**0,607 Kg/m**

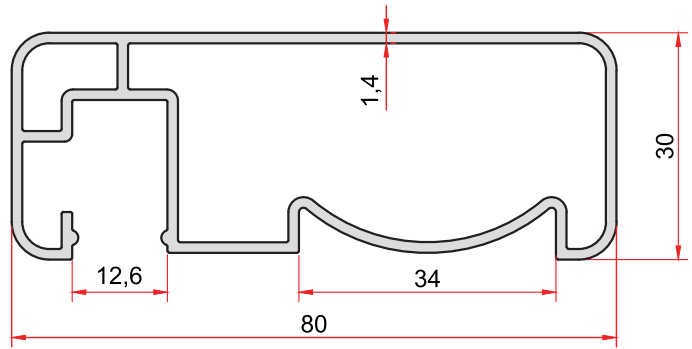

**KOD-CODE** *TEORİK AĞIRLIK*  
**1944** *THEORETICAL WEIGHT*  
**1,004 Kg/m**

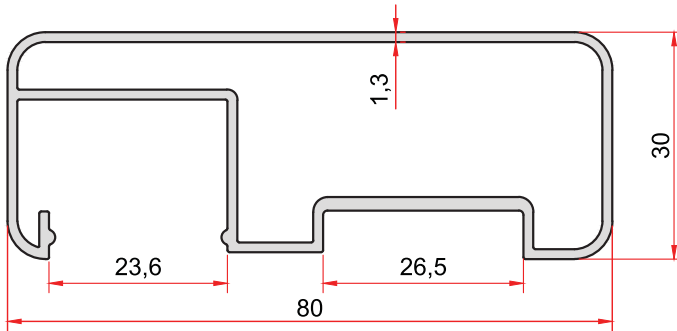

**KOD-CODE** *TEORİK AĞIRLIK*  
**5006** *THEORETICAL WEIGHT*  
**0,915 Kg/m**

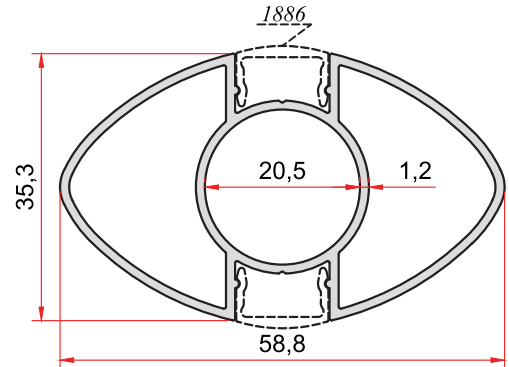

**KOD-CODE** *TEORİK AĞIRLIK*  
**1948** *THEORETICAL WEIGHT*  
**0,702 Kg/m**

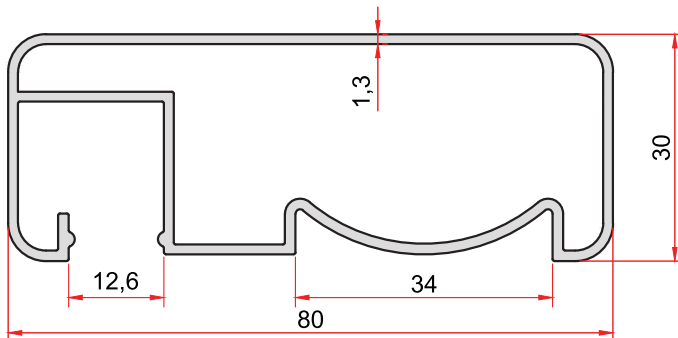

**KOD-CODE** *TEORİK AĞIRLIK*  
**5007** *THEORETICAL WEIGHT*  
**0,915 Kg/m**

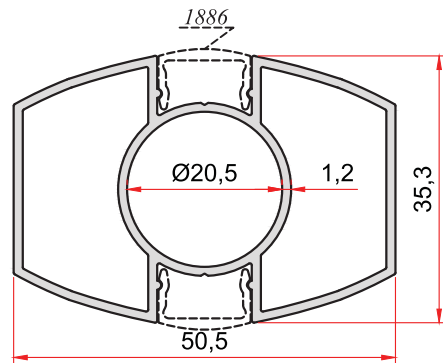

**KOD-CODE** *TEORİK AĞIRLIK*  
**1949** *THEORETICAL WEIGHT*  
**0,710 Kg/m**

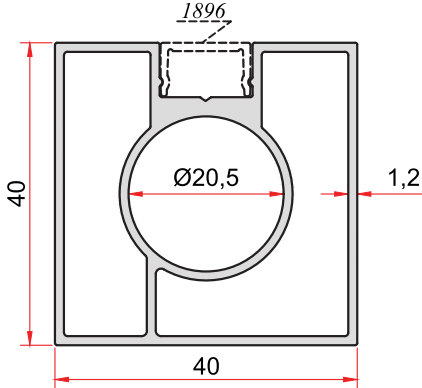

**KOD-CODE** TEORİK AĞIRLIK  
1895 THEORETICAL WEIGHT  
0,845 Kg/m

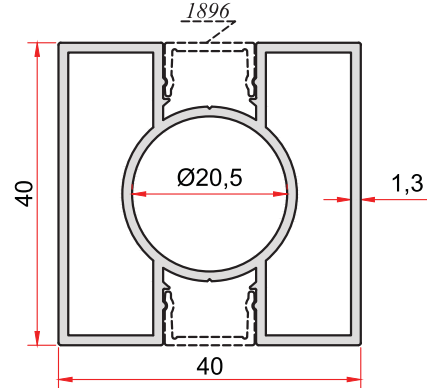

**KOD-CODE** TEORİK AĞIRLIK  
1905 THEORETICAL WEIGHT  
0,837 Kg/m

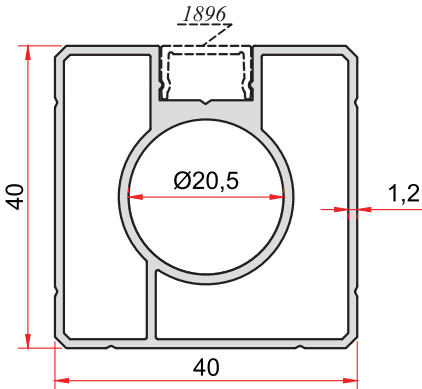

**KOD-CODE** TEORİK AĞIRLIK  
1975 THEORETICAL WEIGHT  
0,845 Kg/m

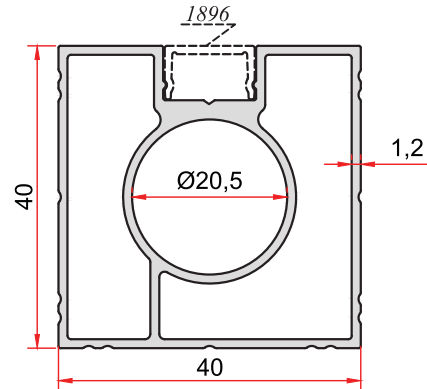

**KOD-CODE** TEORİK AĞIRLIK  
5037 THEORETICAL WEIGHT  
0,823 Kg/m

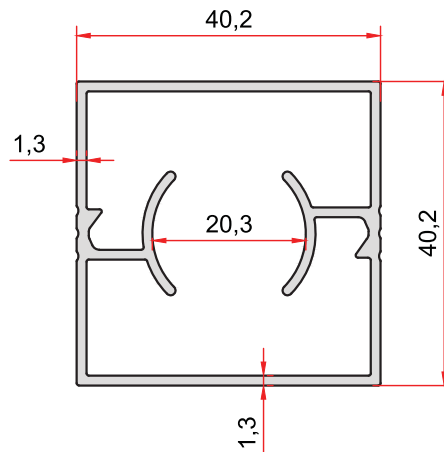

**KOD-CODE** TEORİK AĞIRLIK  
2725 THEORETICAL WEIGHT  
0,748 Kg/m

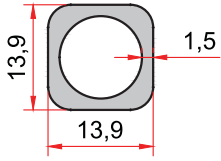

**KOD-CODE** 1906  
**TEORİK AĞIRLIK** 0,248 Kg/m  
**THEORETICAL WEIGHT**

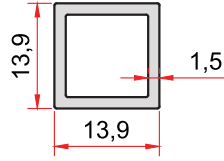

**KOD-CODE** 1960  
**TEORİK AĞIRLIK** 0,199 Kg/m  
**THEORETICAL WEIGHT**

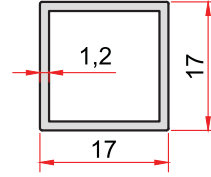

**KOD-CODE** 1985  
**TEORİK AĞIRLIK** 0,203 Kg/m  
**THEORETICAL WEIGHT**

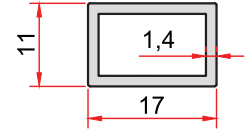

**KOD-CODE** 5064  
**TEORİK AĞIRLIK** 0,189 Kg/m  
**THEORETICAL WEIGHT**

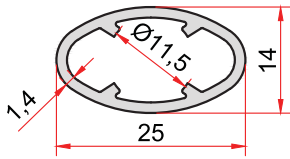

**KOD-CODE** 1973  
**TEORİK AĞIRLIK** 0,249 Kg/m  
**THEORETICAL WEIGHT**

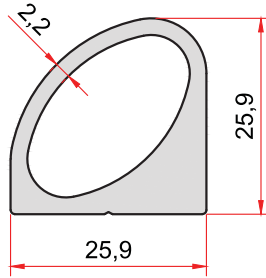

**KOD-CODE** 5013  
**TEORİK AĞIRLIK** 0,707 Kg/m  
**THEORETICAL WEIGHT**

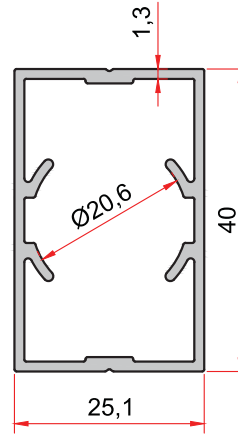

**KOD-CODE** 1992  
**TEORİK AĞIRLIK** 0,545 Kg/m  
**THEORETICAL WEIGHT**

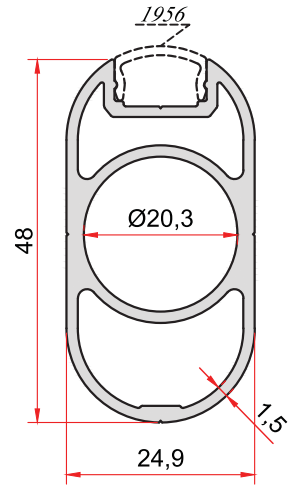

**KOD-CODE** 1955  
**TEORİK AĞIRLIK** 0,832 Kg/m  
**THEORETICAL WEIGHT**

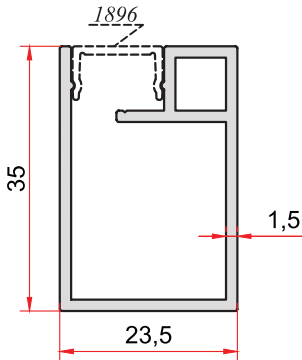

**KOD-CODE** 5052  
**TEORİK AĞIRLIK** 0,488 Kg/m  
**THEORETICAL WEIGHT**

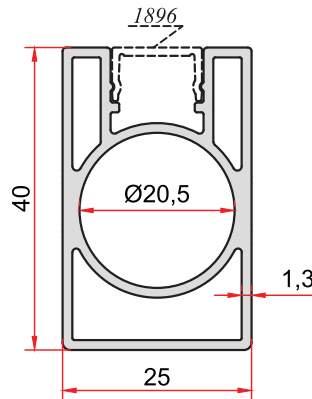

**KOD-CODE** 5049  
**TEORİK AĞIRLIK** 0,723 Kg/m  
**THEORETICAL WEIGHT**

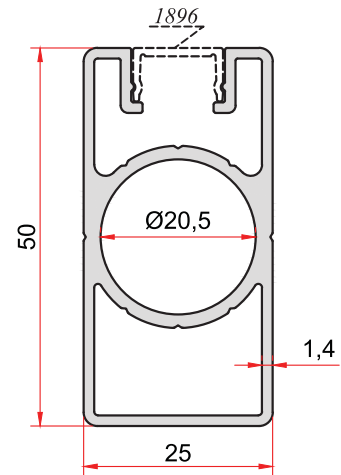

**KOD-CODE** 5014  
**TEORİK AĞIRLIK** 0,885 Kg/m  
**THEORETICAL WEIGHT**

# Küpeşte Profilleri

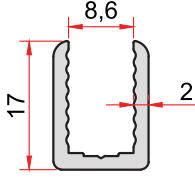

**KOD-CODE** TEORİK AĞIRLIK  
5001 THEORETICAL WEIGHT  
0,213 Kg/m

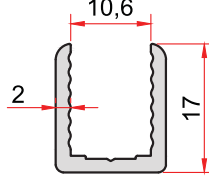

**KOD-CODE** TEORİK AĞIRLIK  
5002 THEORETICAL WEIGHT  
0,221 Kg/m

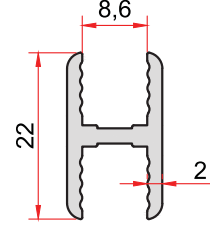

**KOD-CODE** TEORİK AĞIRLIK  
5003 THEORETICAL WEIGHT  
0,270 Kg/m

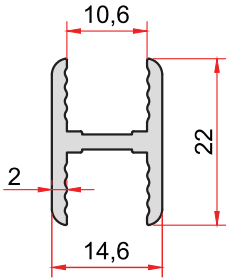

**KOD-CODE** TEORİK AĞIRLIK  
5004 THEORETICAL WEIGHT  
0,281 Kg/m

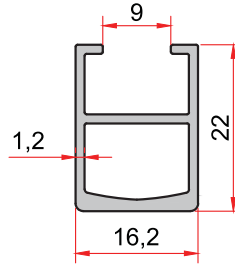

**KOD-CODE** TEORİK AĞIRLIK  
1950 THEORETICAL WEIGHT  
0,273 Kg/m

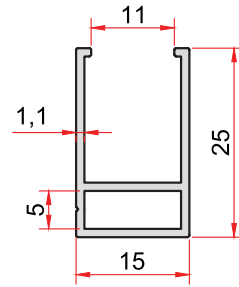

**KOD-CODE** TEORİK AĞIRLIK  
1141 THEORETICAL WEIGHT  
0,229 Kg/m

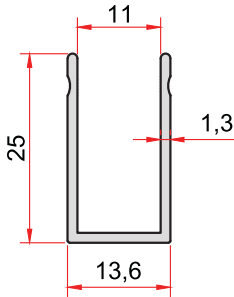

**KOD-CODE** TEORİK AĞIRLIK  
5015 THEORETICAL WEIGHT  
0,210 Kg/m

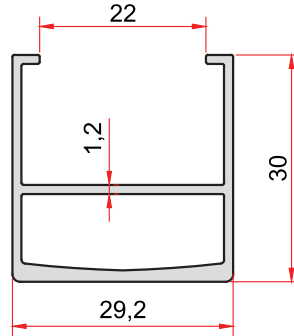

**KOD-CODE** TEORİK AĞIRLIK  
5008 THEORETICAL WEIGHT  
0,432 Kg/m

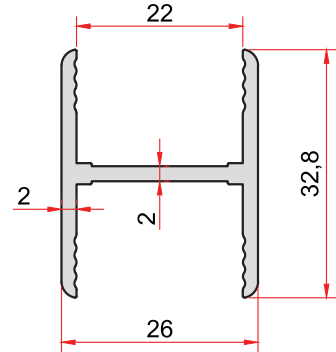

**KOD-CODE** TEORİK AĞIRLIK  
5009 THEORETICAL WEIGHT  
0,459 Kg/m

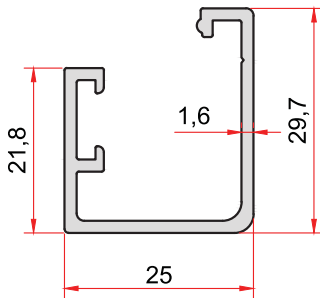

**KOD-CODE** TEORİK AĞIRLIK  
1937 THEORETICAL WEIGHT  
0,392 Kg/m

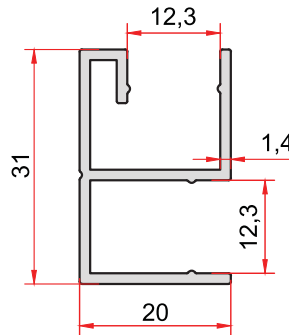

**KOD-CODE** TEORİK AĞIRLIK  
5077 THEORETICAL WEIGHT  
0,359 Kg/m

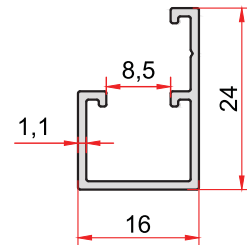

**KOD-CODE** TEORİK AĞIRLIK  
5080 THEORETICAL WEIGHT  
0,180 Kg/m

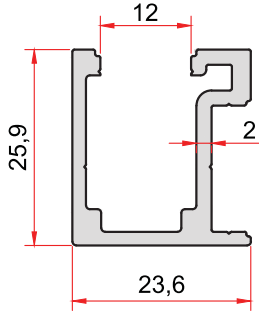

**KOD-CODE** *TEORİK AĞIRLIK*  
**1959** *THEORETICAL WEIGHT*  
**0,475 Kg/m**

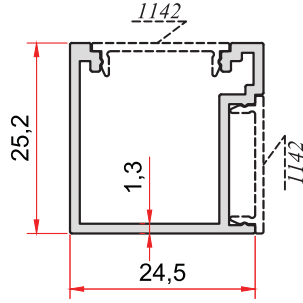

**KOD-CODE** *TEORİK AĞIRLIK*  
**1140** *THEORETICAL WEIGHT*  
**0,311 Kg/m**

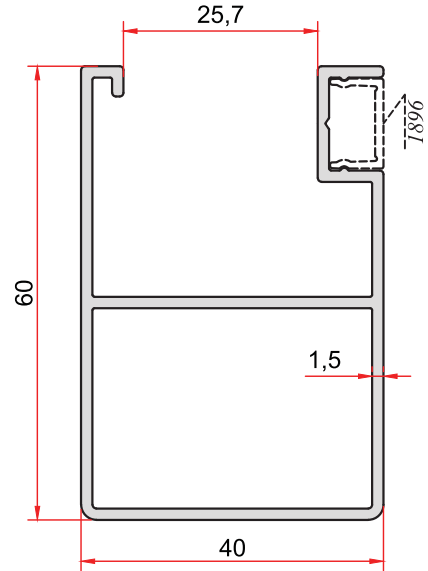

**KOD-CODE** *TEORİK AĞIRLIK*  
**5048** *THEORETICAL WEIGHT*  
**0,866 Kg/m**

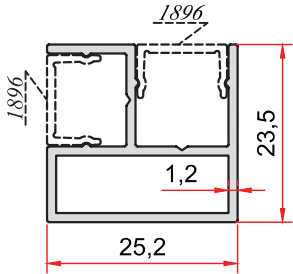

**KOD-CODE** *TEORİK AĞIRLIK*  
**5063** *THEORETICAL WEIGHT*  
**0,335 Kg/m**

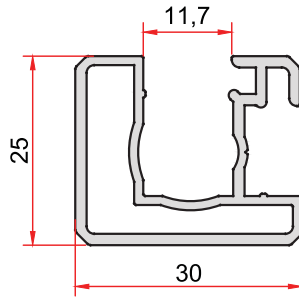

**KOD-CODE** *TEORİK AĞIRLIK*  
**1908** *THEORETICAL WEIGHT*  
**0,508 Kg/m**

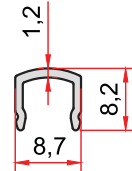

**KOD-CODE** *TEORİK AĞIRLIK*  
**5101** *THEORETICAL WEIGHT*  
**0,062 Kg/m**

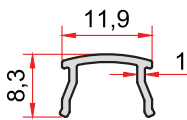

**KOD-CODE** *TEORİK AĞIRLIK*  
**1924** *THEORETICAL WEIGHT*  
**0,070 Kg/m**

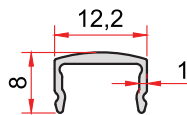

**KOD-CODE** *TEORİK AĞIRLIK*  
**1886** *THEORETICAL WEIGHT*  
**0,073 Kg/m**

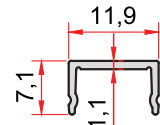

**KOD-CODE** *TEORİK AĞIRLIK*  
**1896** *THEORETICAL WEIGHT*  
**0,065 Kg/m**

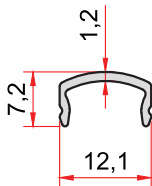

**KOD-CODE** *TEORİK AĞIRLIK*  
**1956** *THEORETICAL WEIGHT*  
**0,064 Kg/m**

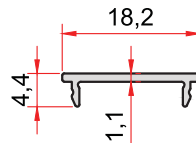

**KOD-CODE** *TEORİK AĞIRLIK*  
**1142** *THEORETICAL WEIGHT*  
**0,068 Kg/m**

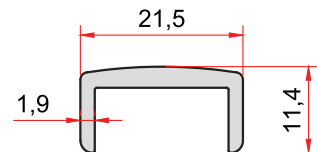

**KOD-CODE** *TEORİK AĞIRLIK*  
**1122** *THEORETICAL WEIGHT*  
**0,229 Kg/m**



# Küpeşte Profilleri

**ARFEM**<sup>®</sup>  
ALÜMİNYUM

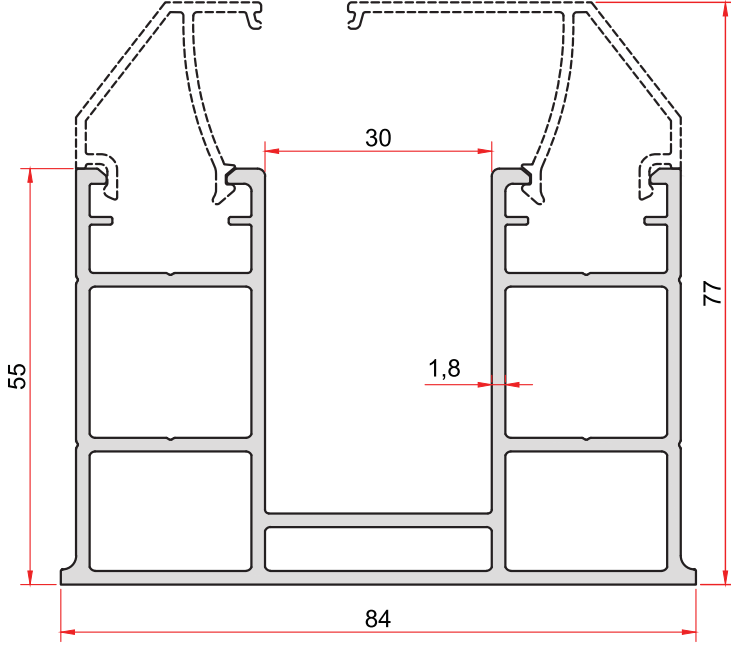

**KOD-CODE** TEORİK AĞIRLIK  
THEORETICAL WEIGHT  
**1978** **2,098 Kg/m**

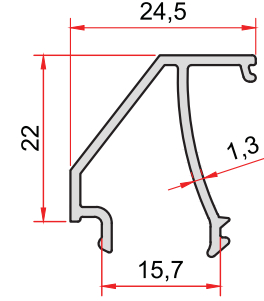

**KOD-CODE** TEORİK AĞIRLIK  
THEORETICAL WEIGHT  
**1979** **0,267 Kg/m**

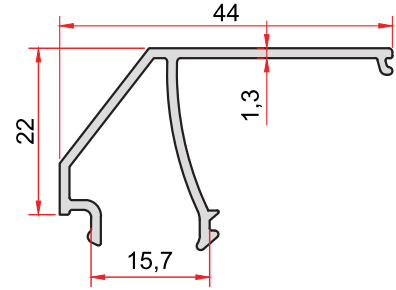

**KOD-CODE** TEORİK AĞIRLIK  
THEORETICAL WEIGHT  
**1981** **0,335 Kg/m**

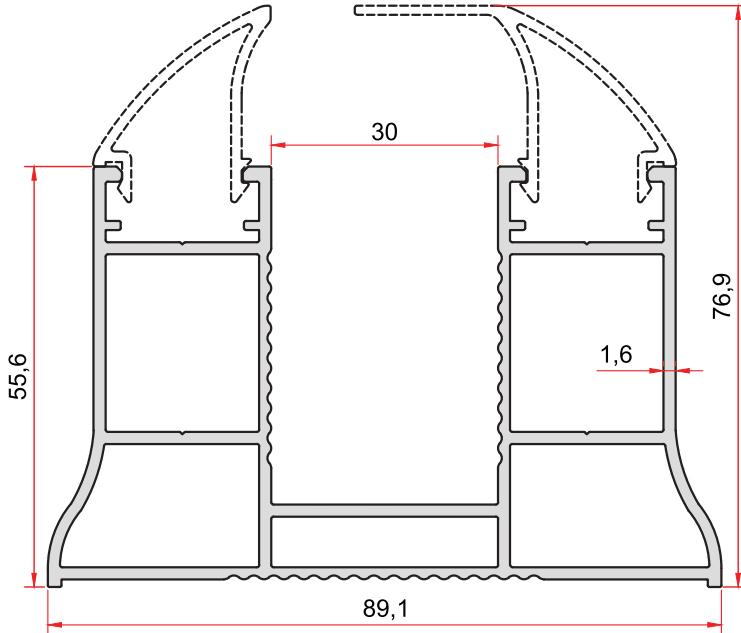

**KOD-CODE** TEORİK AĞIRLIK  
THEORETICAL WEIGHT  
**5017** **1,804 Kg/m**

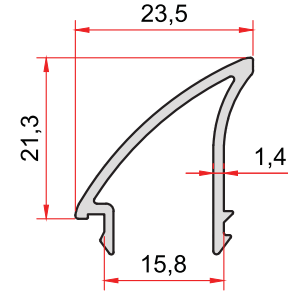

**KOD-CODE** TEORİK AĞIRLIK  
THEORETICAL WEIGHT  
**5019** **0,251 Kg/m**

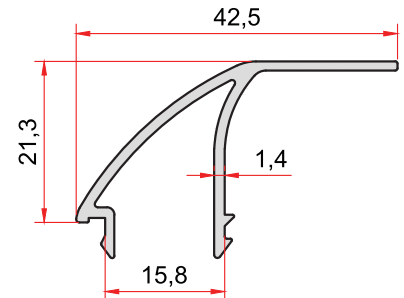

**KOD-CODE** TEORİK AĞIRLIK  
THEORETICAL WEIGHT  
**5018** **0,313 Kg/m**

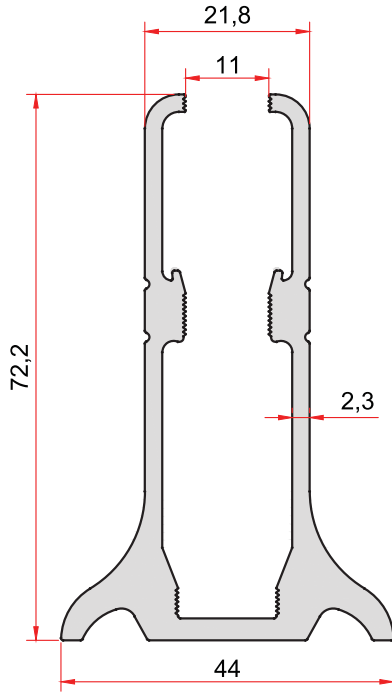

**KOD-CODE** *TEORİK AĞIRLIK*  
*THEORETICAL WEIGHT*  
**1875** **1,639 Kg/m**

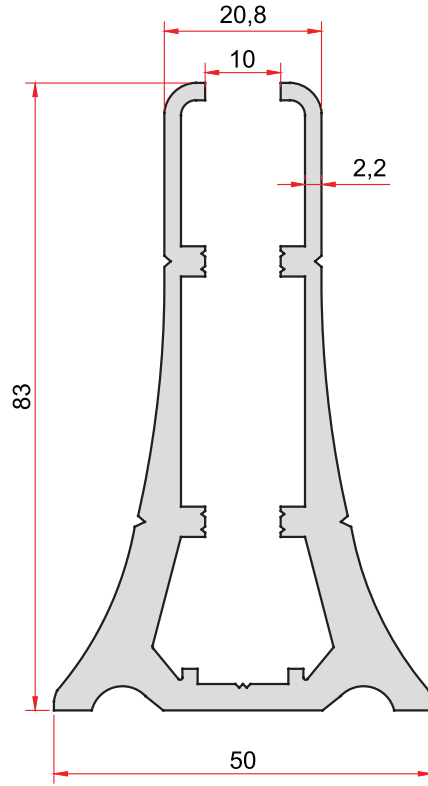

**KOD-CODE** *TEORİK AĞIRLIK*  
*THEORETICAL WEIGHT*  
**1877** **2,349 Kg/m**

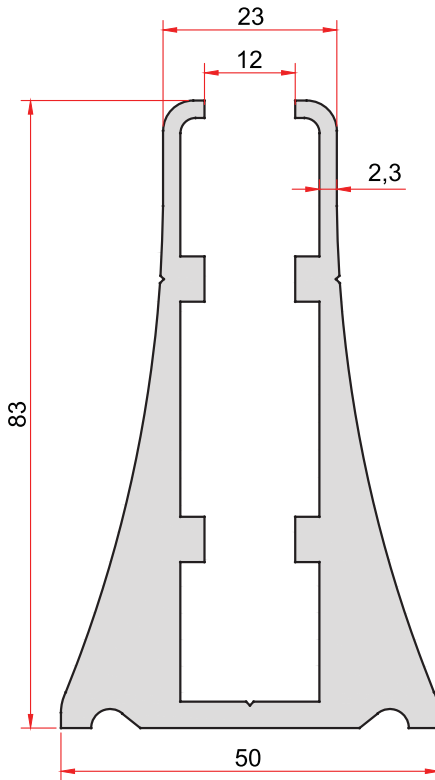

**KOD-CODE** *TEORİK AĞIRLIK*  
*THEORETICAL WEIGHT*  
**1879** **3,226 Kg/m**

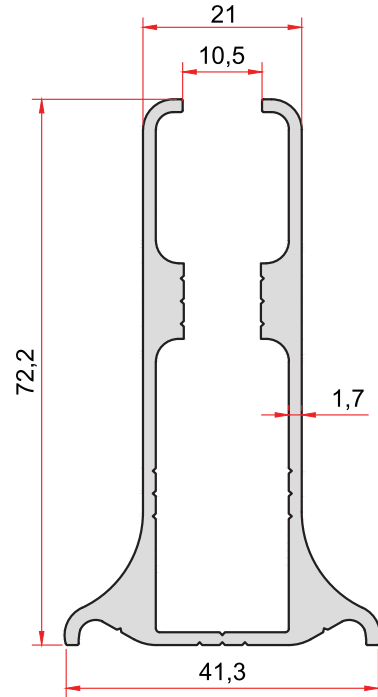

**KOD-CODE** *TEORİK AĞIRLIK*  
*THEORETICAL WEIGHT*  
**1930** **1,299 Kg/m**

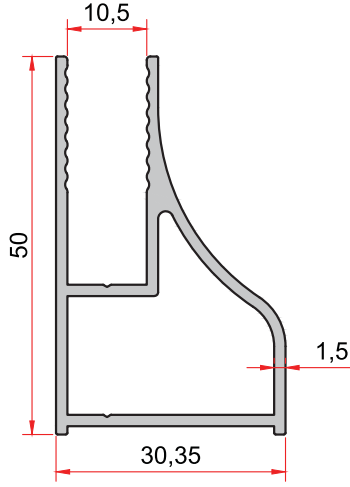

**KOD-CODE** *TEORİK AĞIRLIK*  
*THEORETICAL WEIGHT*  
**1899** **0,651 Kg/m**

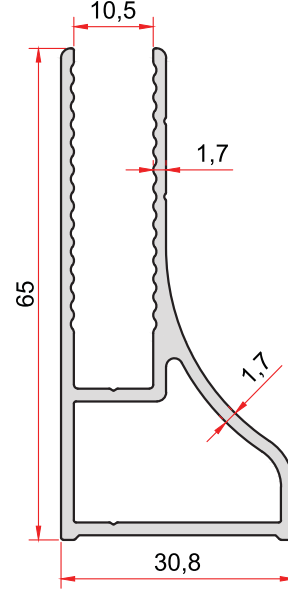

**KOD-CODE** *TEORİK AĞIRLIK*  
*THEORETICAL WEIGHT*  
**1914** **0,826 Kg/m**

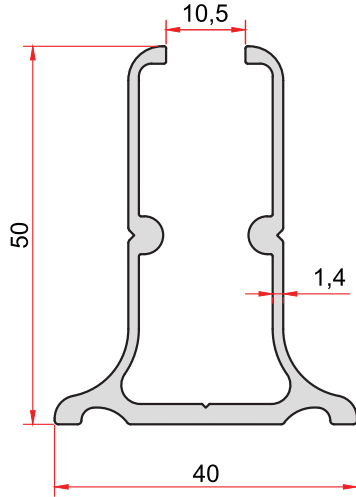

**KOD-CODE** *TEORİK AĞIRLIK*  
*THEORETICAL WEIGHT*  
**5039** **0,756 Kg/m**

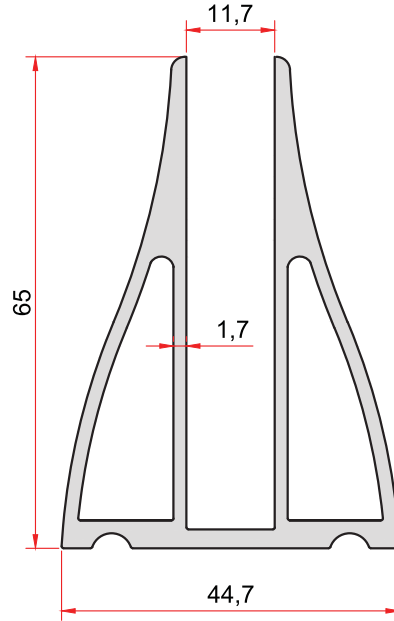

**KOD-CODE** *TEORİK AĞIRLIK*  
*THEORETICAL WEIGHT*  
**1953** **1,571 Kg/m**

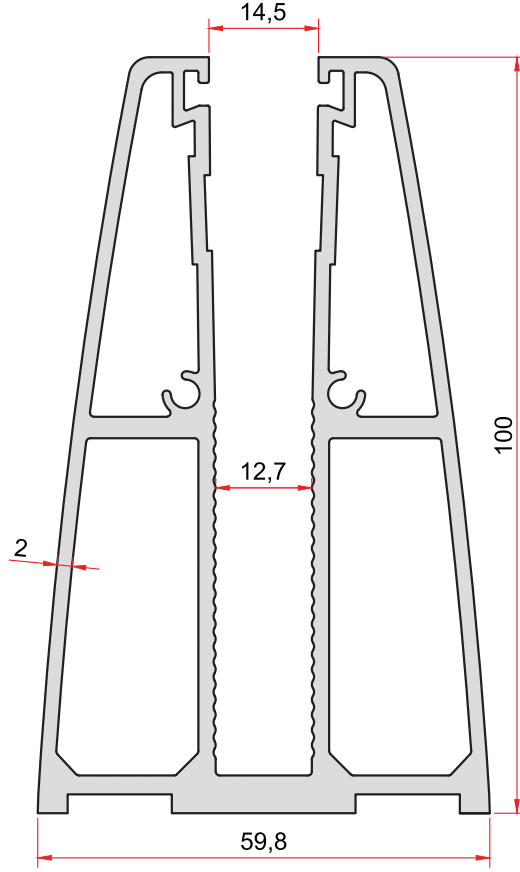

**KOD-CODE**      *TEORİK AĞIRLIK*  
*THEORETICAL WEIGHT*  
**1938**              **3,205 Kg/m**

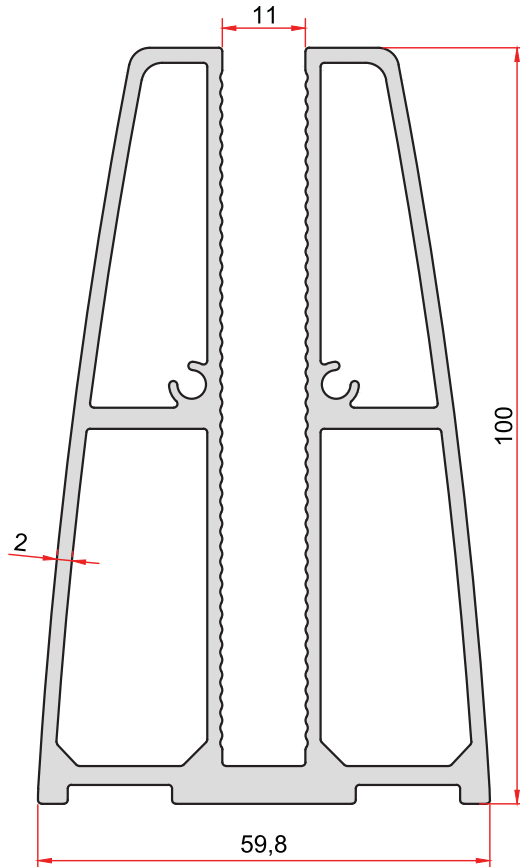

**KOD-CODE**      *TEORİK AĞIRLIK*  
*THEORETICAL WEIGHT*  
**5060**              **3,048 Kg/m**

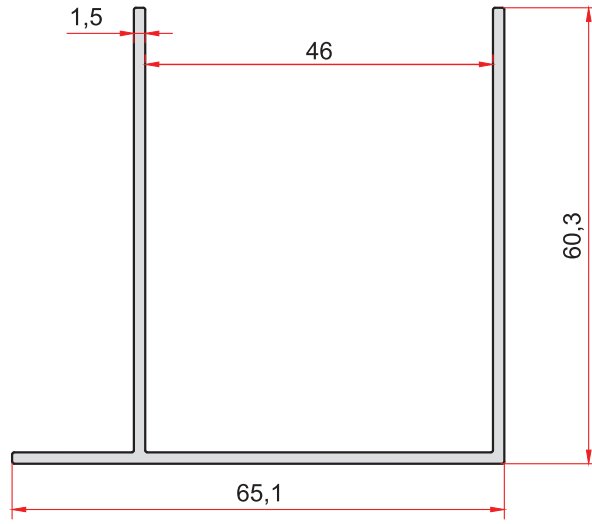

**KOD-CODE**      *TEORİK AĞIRLIK*  
7040              *THEORETICAL WEIGHT*  
0,739 Kg/m

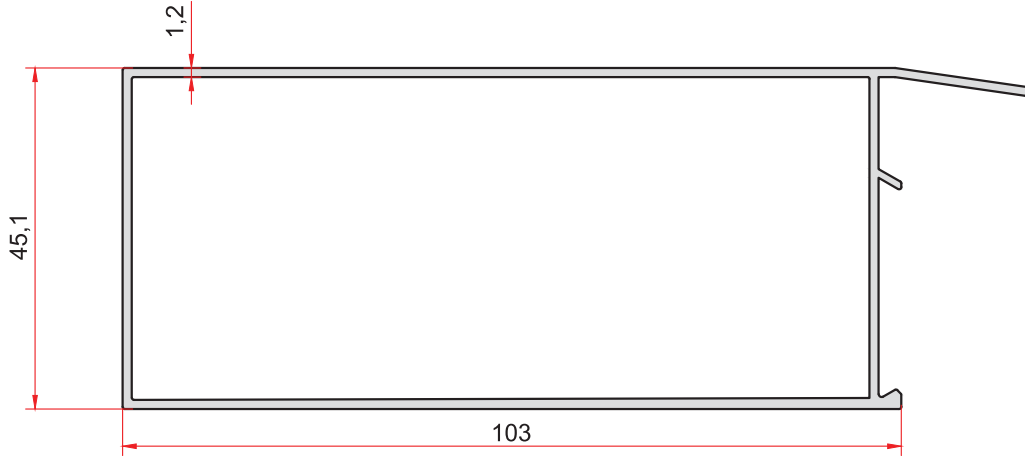

**KOD-CODE**      *TEORİK AĞIRLIK*  
7041              *THEORETICAL WEIGHT*  
1,015 Kg/m

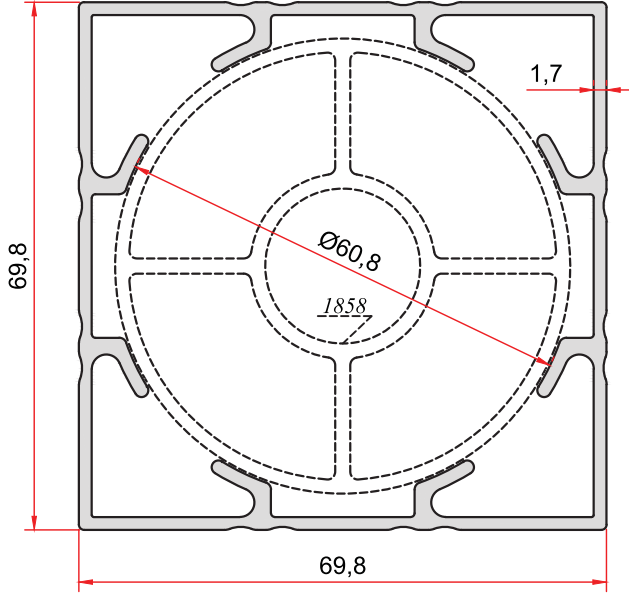

**KOD-CODE** *TEORİK AĞIRLIK*  
*THEORETICAL WEIGHT*  
**1898** **1,687 Kg/m**

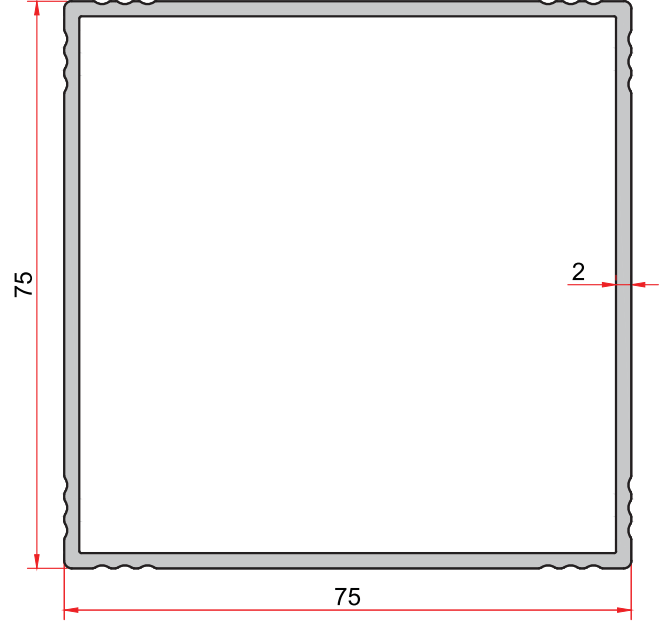

**KOD-CODE** *TEORİK AĞIRLIK*  
*THEORETICAL WEIGHT*  
**5021** **1,536 Kg/m**

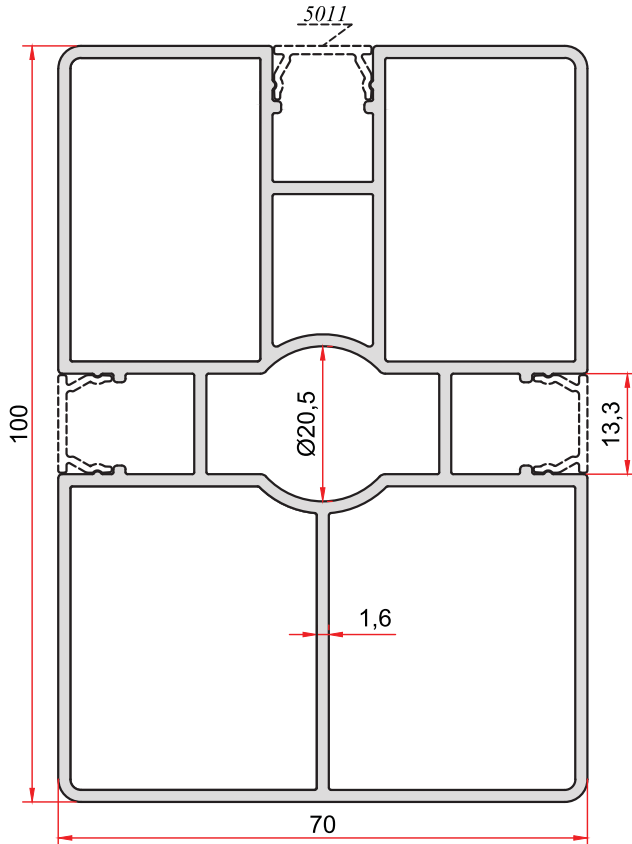

**KOD-CODE** *TEORİK AĞIRLIK*  
*THEORETICAL WEIGHT*  
**5047** **2,549 Kg/m**

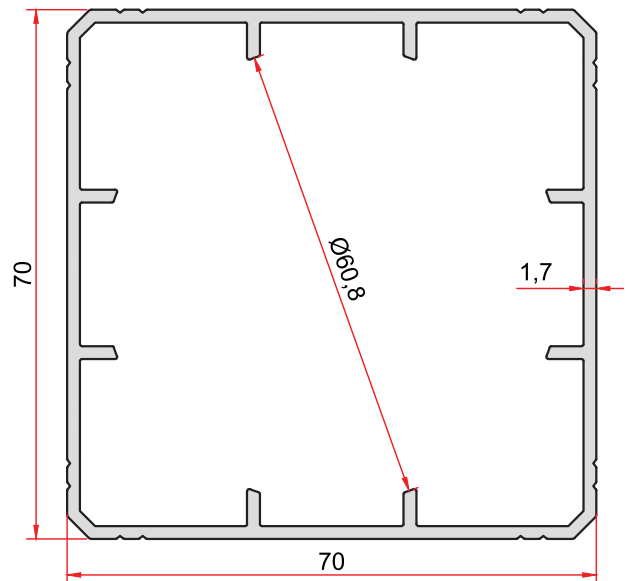

**KOD-CODE** *TEORİK AĞIRLIK*  
*THEORETICAL WEIGHT*  
**5044** **1,390 Kg/m**

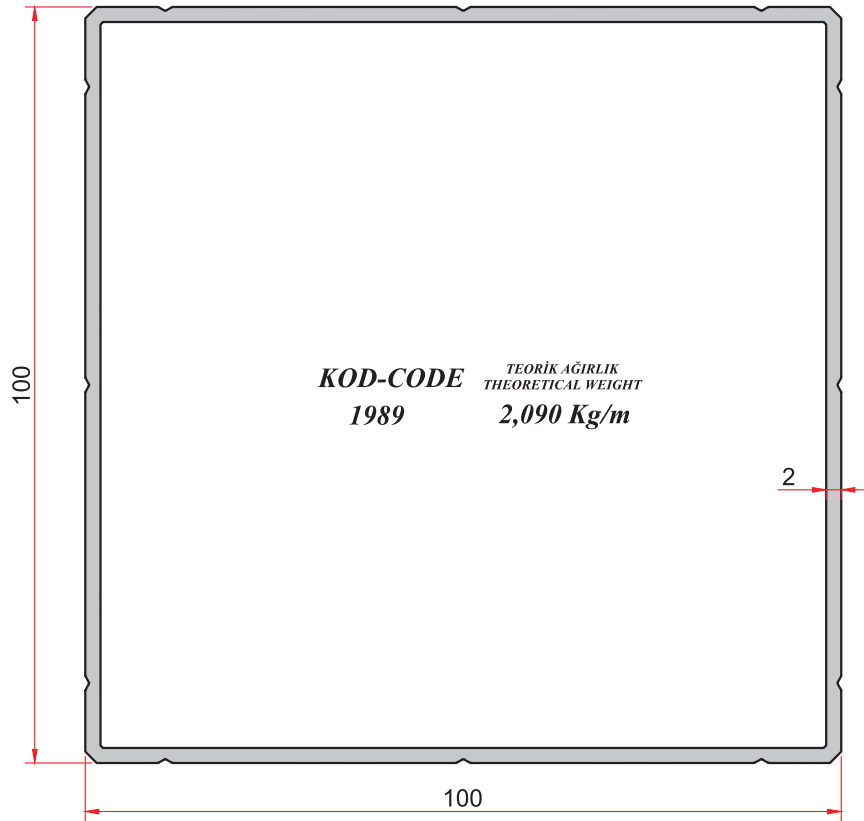
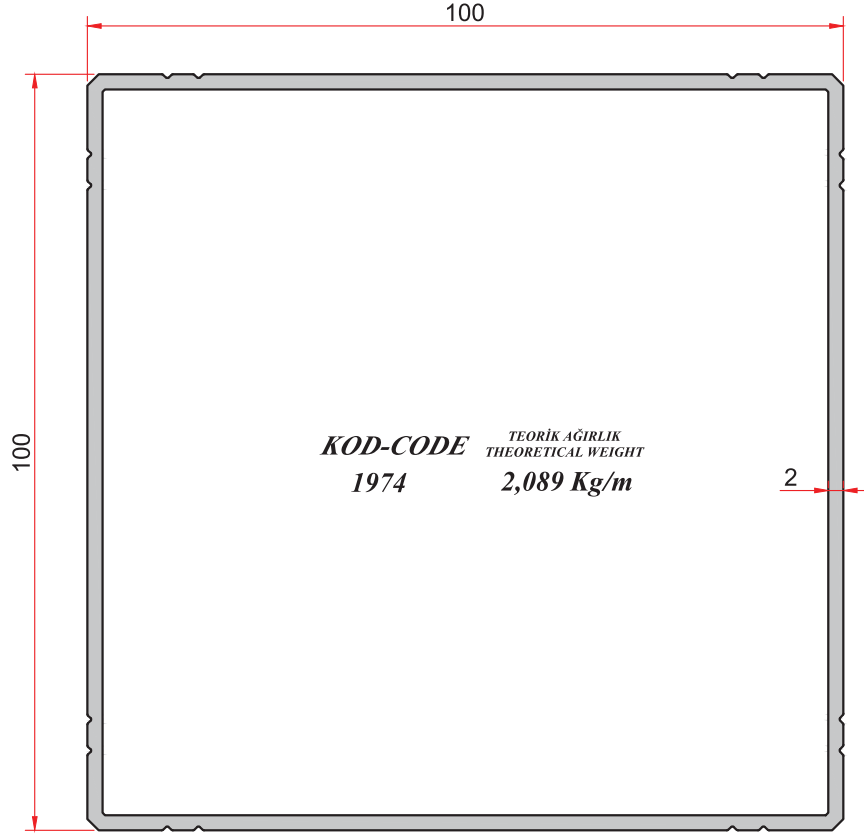

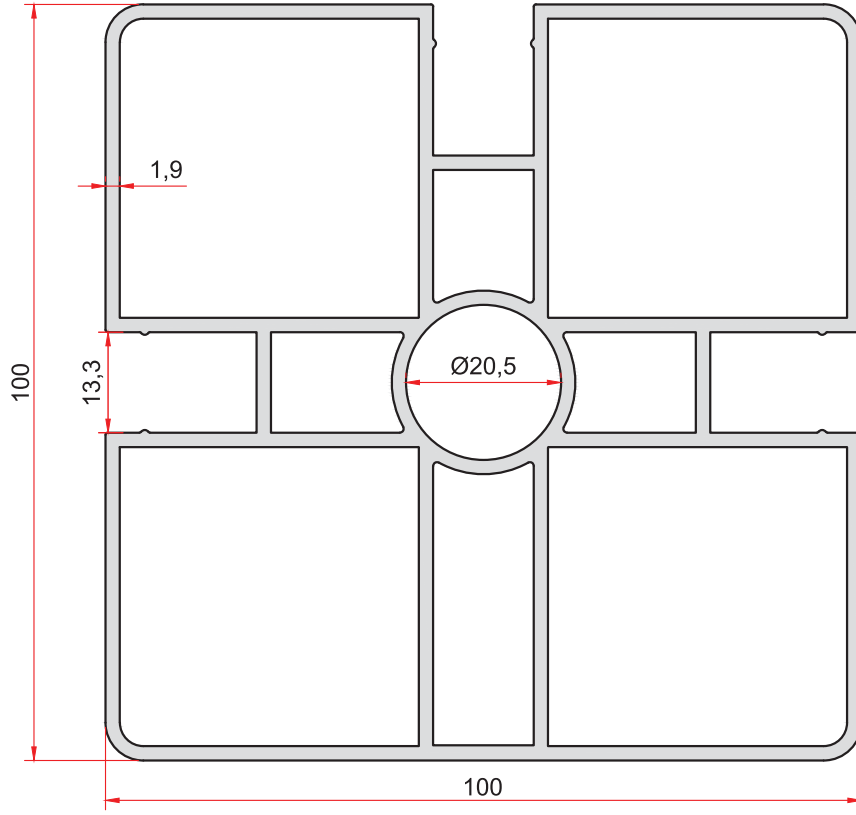

**KOD-CODE** TEORİK AĞIRLIK  
THEORETICAL WEIGHT  
**5010** **3,966 Kg/m**

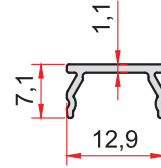

**KOD-CODE** TEORİK AĞIRLIK  
THEORETICAL WEIGHT  
**5011** **0,069 Kg/m**

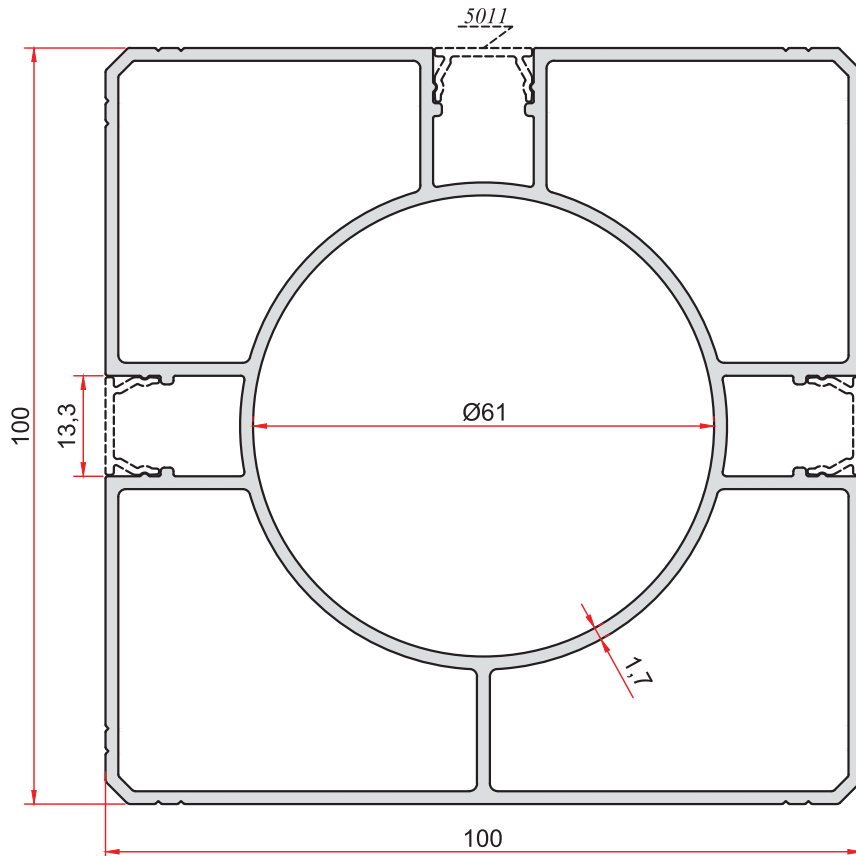

**KOD-CODE** TEORİK AĞIRLIK  
THEORETICAL WEIGHT  
**5040** **3,078 Kg/m**



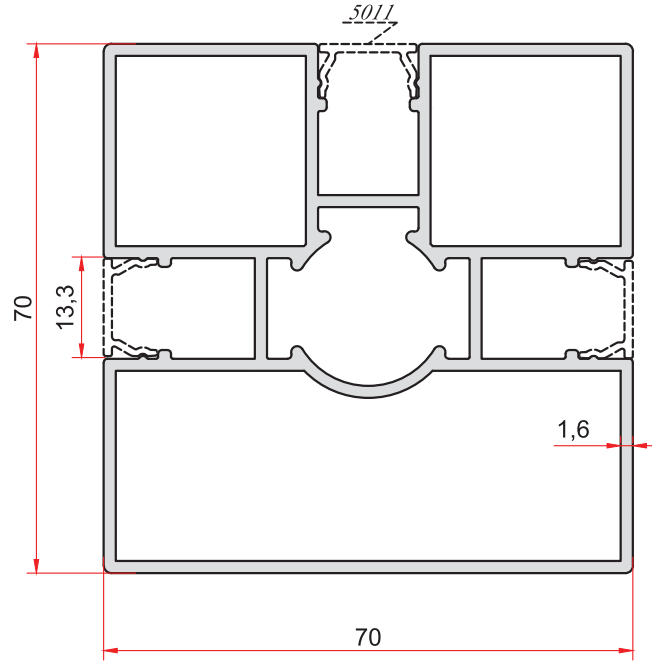

**KOD-CODE**      **TEORİK AĞIRLIK**  
**5065**            **THEORETICAL WEIGHT**  
                         **2,001 Kg/m**

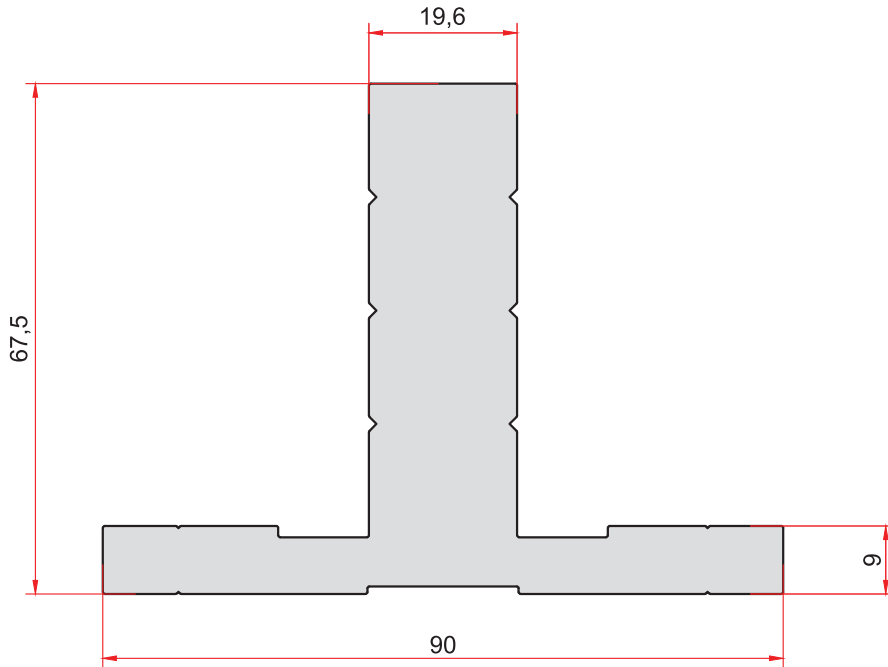

**KOD-CODE**      **TEORİK AĞIRLIK**  
**159**              **THEORETICAL WEIGHT**  
                         **5,113 Kg/m**

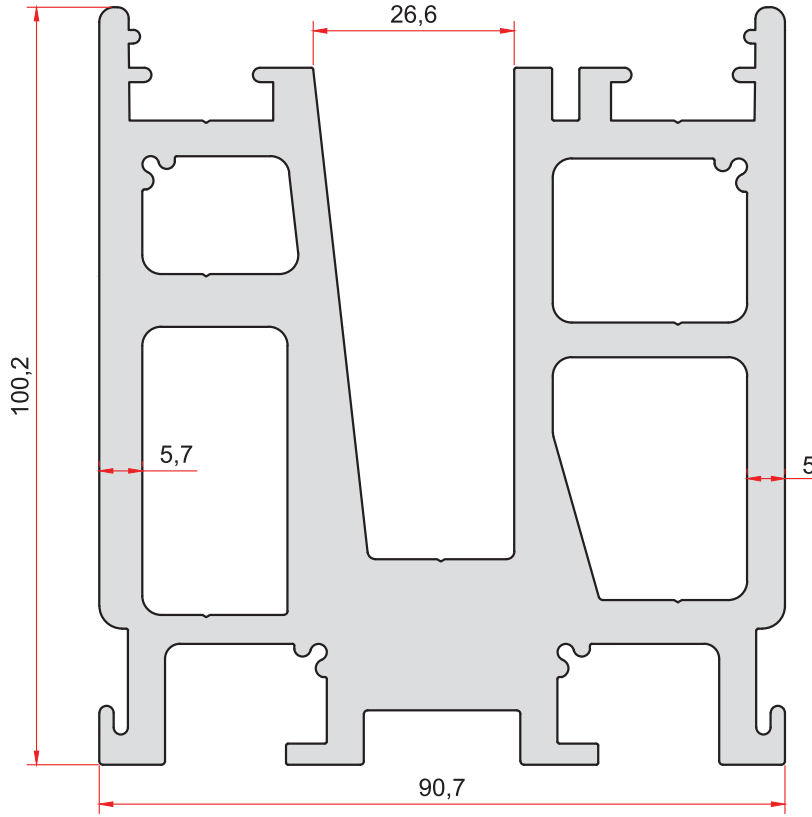

**KOD-CODE** *TEORİK AĞIRLIK*  
*THEORETICAL WEIGHT*  
**1945** **9,310 Kg/m**

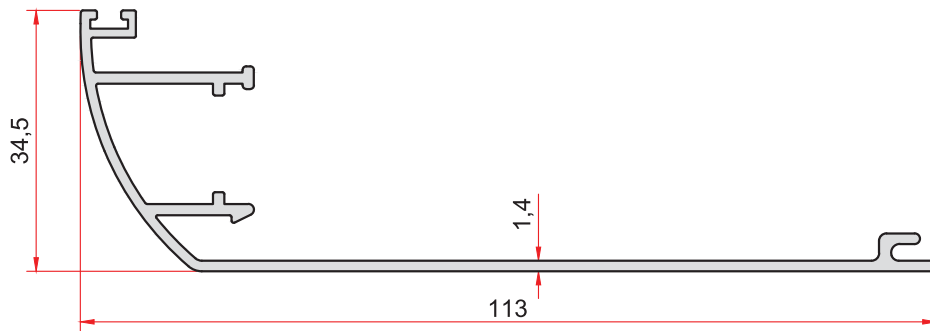

**KOD-CODE** *TEORİK AĞIRLIK*  
*THEORETICAL WEIGHT*  
**1946** **0,737 Kg/m**

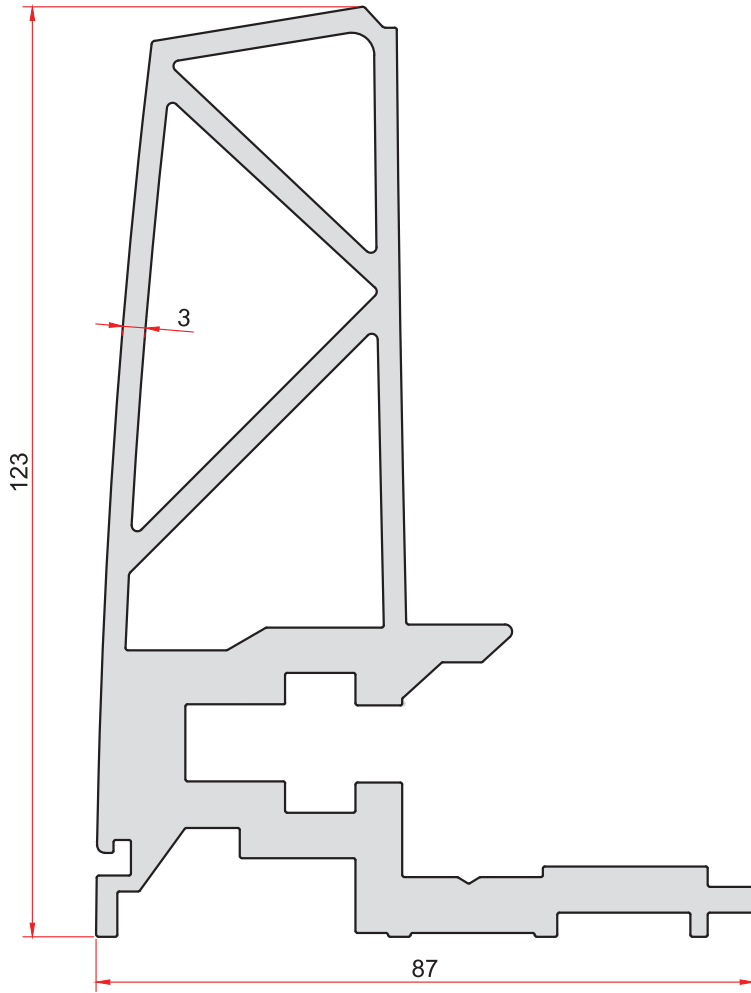

**KOD-CODE** *TEORİK AĞIRLIK*  
*THEORETICAL WEIGHT*  
**1995** **5,581 Kg/m**

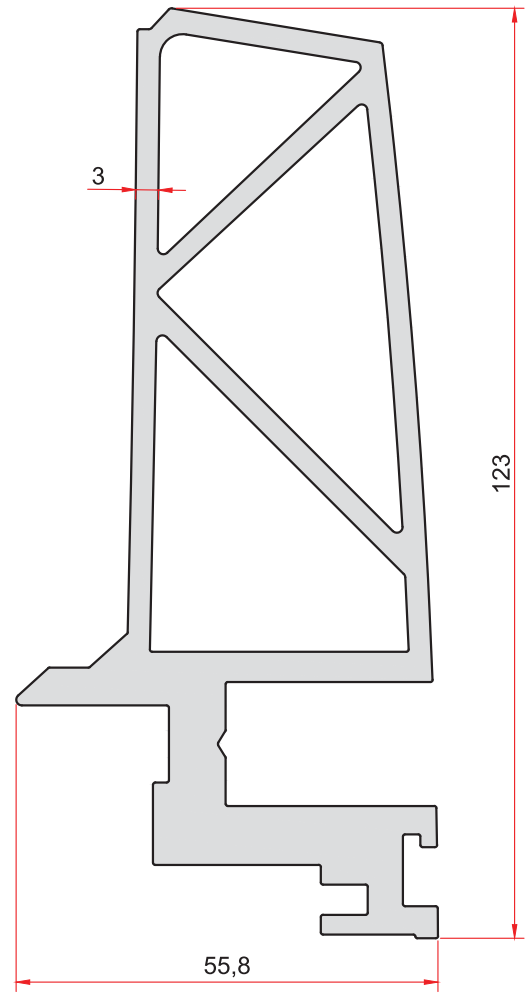

**KOD-CODE** *TEORİK AĞIRLIK*  
*THEORETICAL WEIGHT*  
**1994** **4,282 Kg/m**

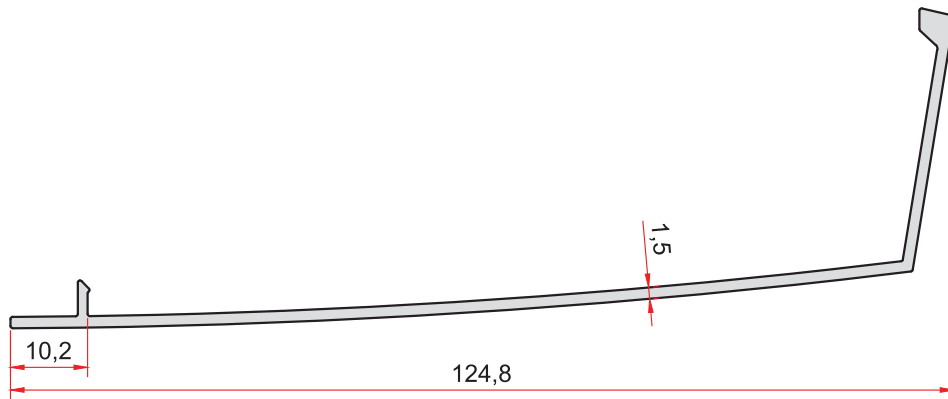

**KOD-CODE** *TEORİK AĞIRLIK*  
*THEORETICAL WEIGHT*  
**1996** **0,662 Kg/m**

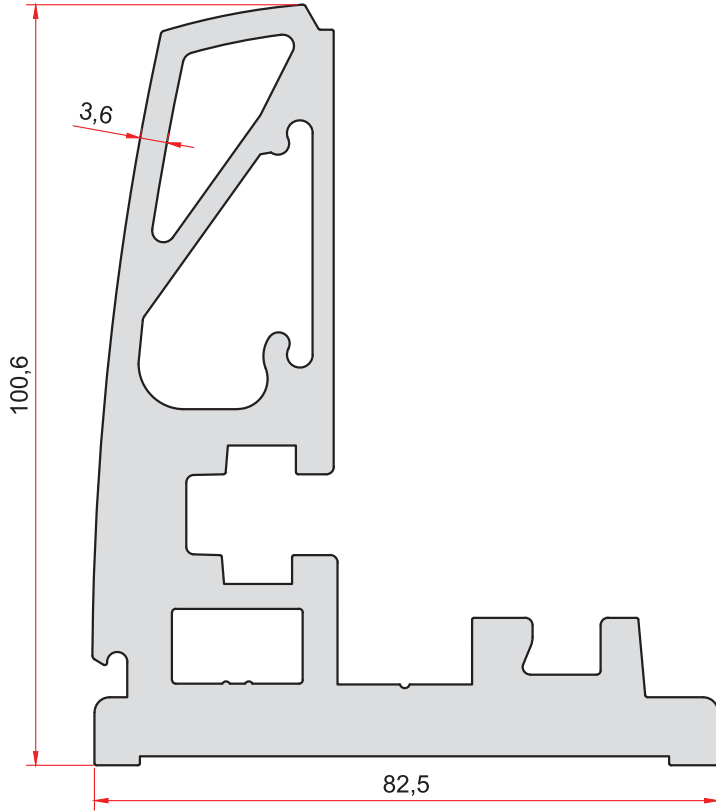

**KOD-CODE** *TEORİK AĞIRLIK*  
*THEORETICAL WEIGHT*  
**2277** **5,918 Kg/m**

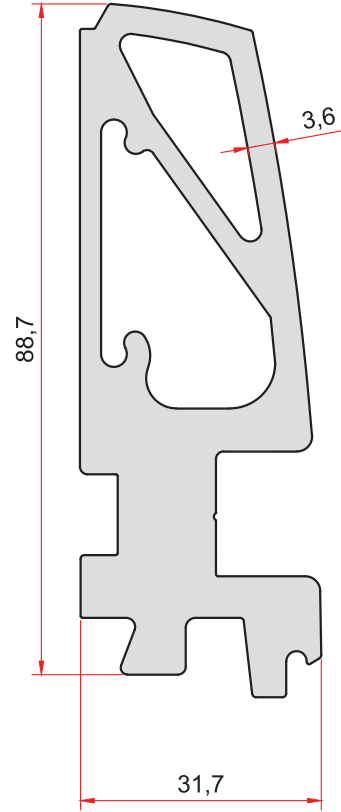

**KOD-CODE** *TEORİK AĞIRLIK*  
*THEORETICAL WEIGHT*  
**2276** **3,591 Kg/m**

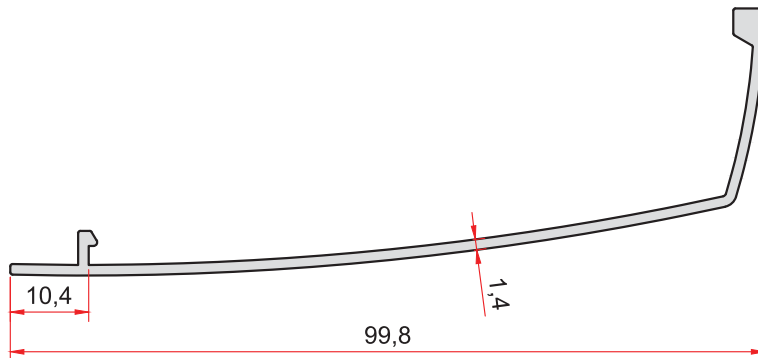

**KOD-CODE** *TEORİK AĞIRLIK*  
*THEORETICAL WEIGHT*  
**2275** **0,510 Kg/m**

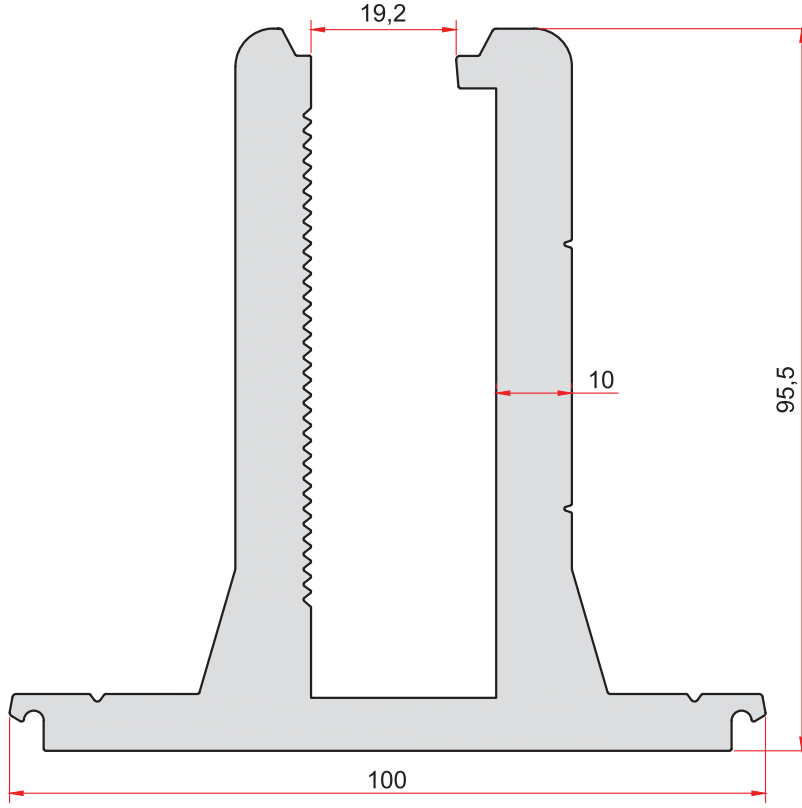

**KOD-CODE** *TEORİK AĞIRLIK*  
*THEORETICAL WEIGHT*  
**2278** **6,755 Kg/m**

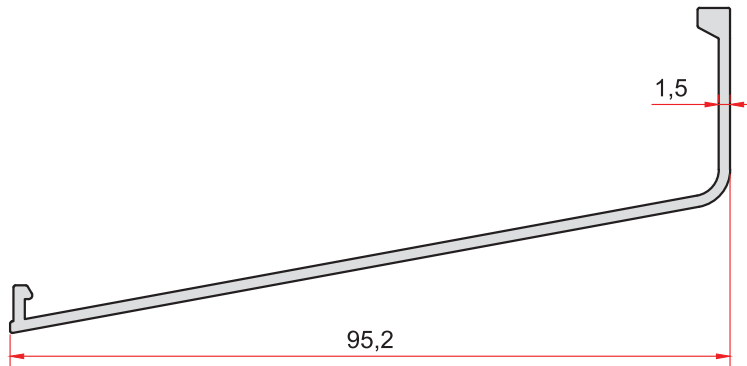

**KOD-CODE** *TEORİK AĞIRLIK*  
*THEORETICAL WEIGHT*  
**2279** **0,532 Kg/m**

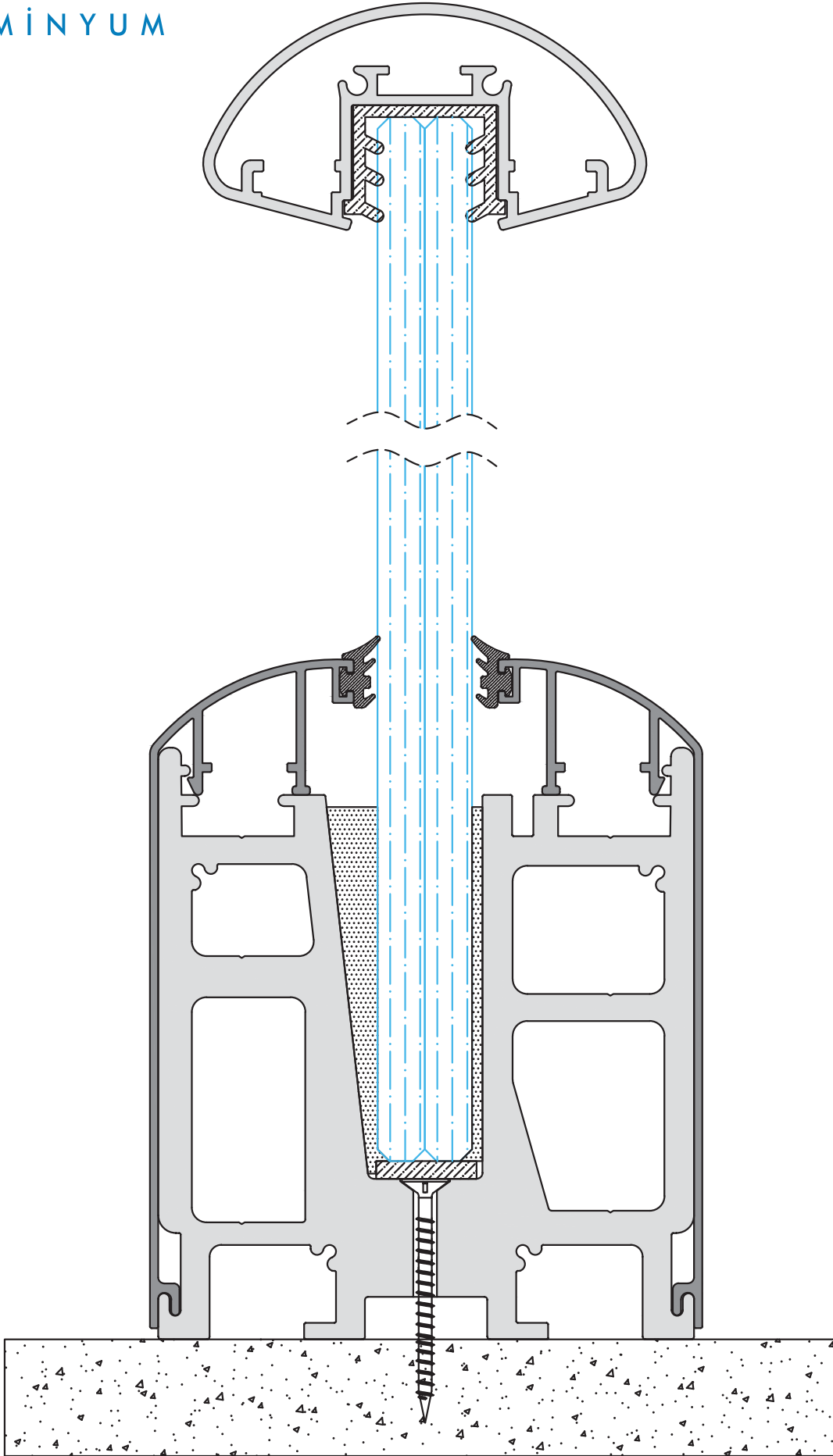

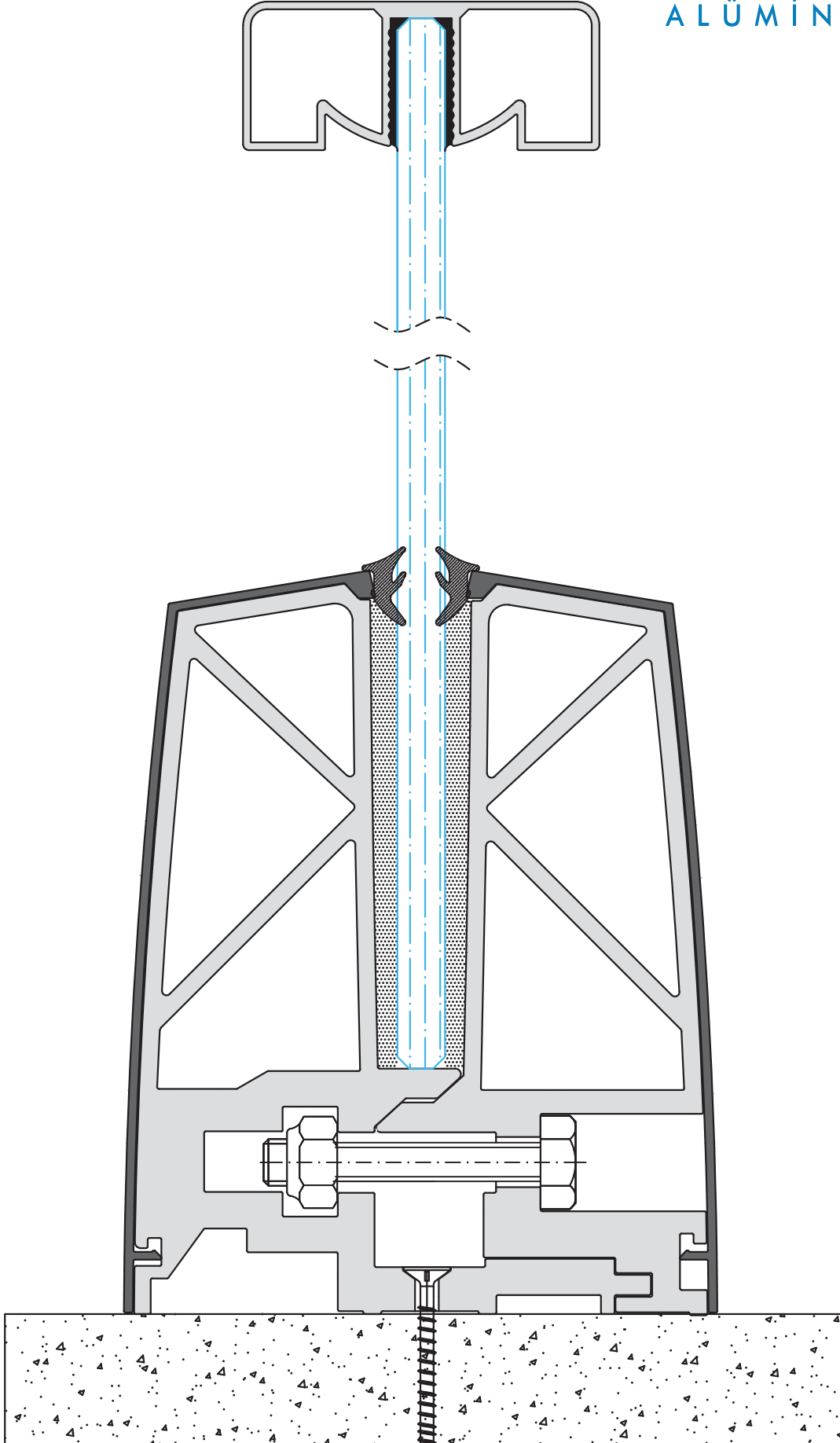







**ARFEM**<sup>®</sup>

ALÜMİNYUM

**Perde Profilleri**

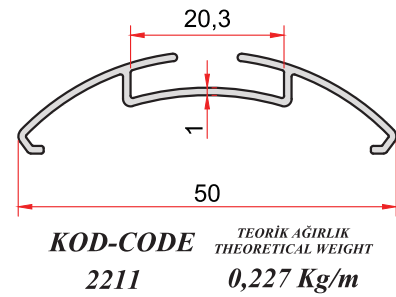
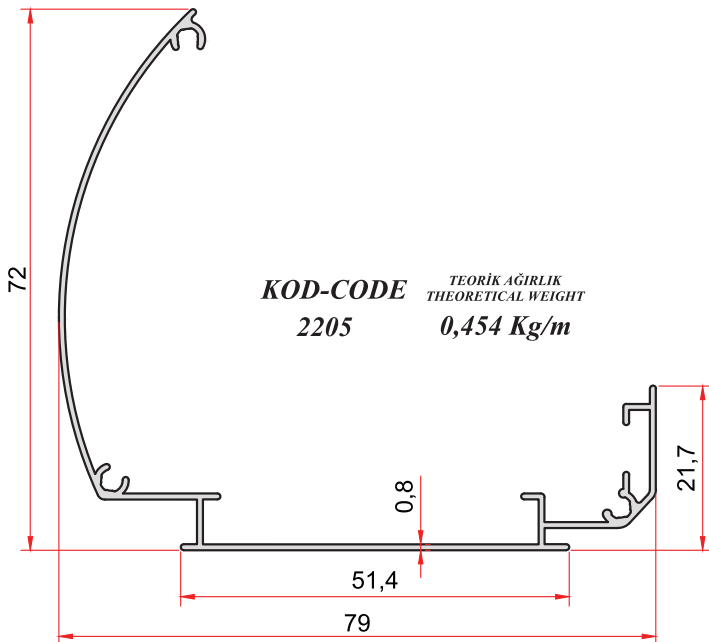
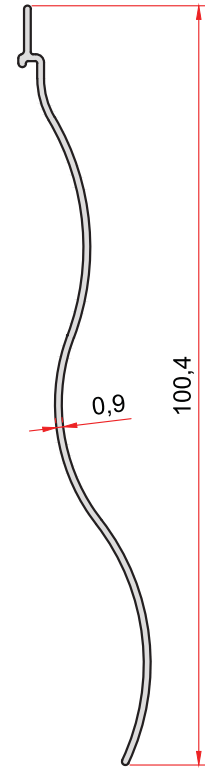
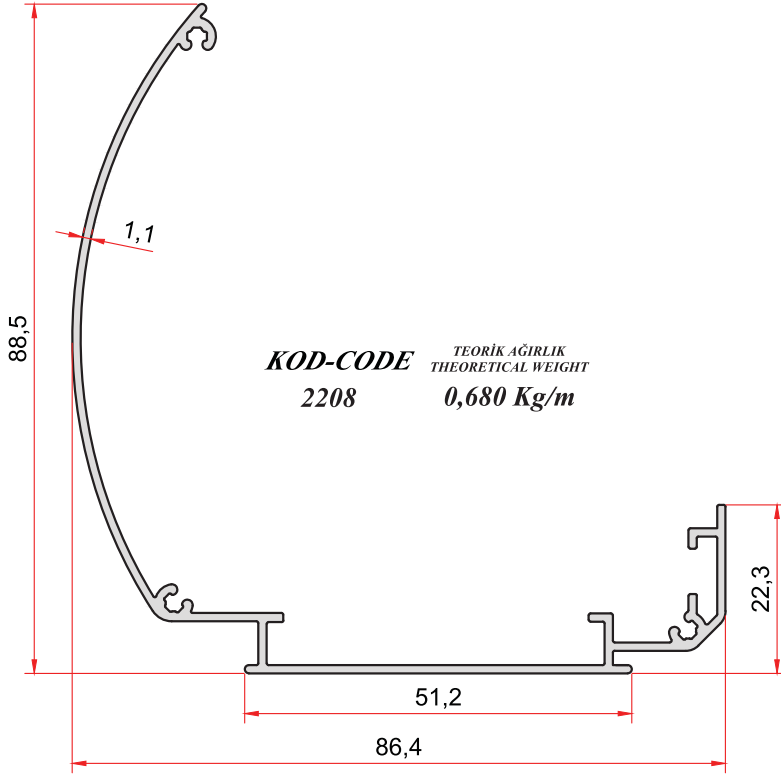

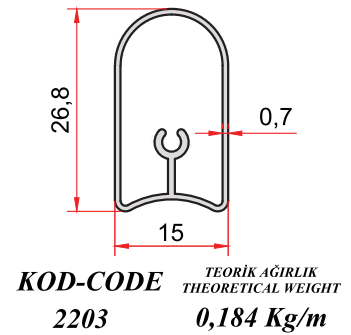
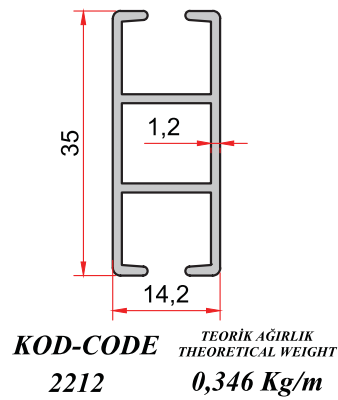
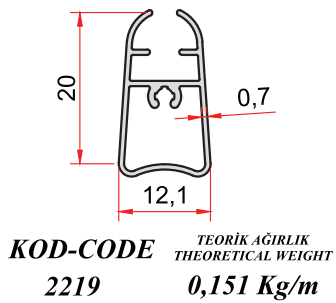
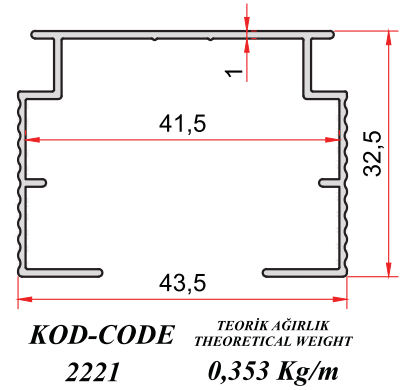
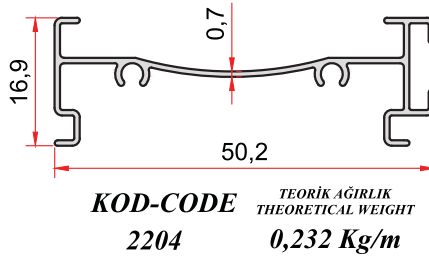
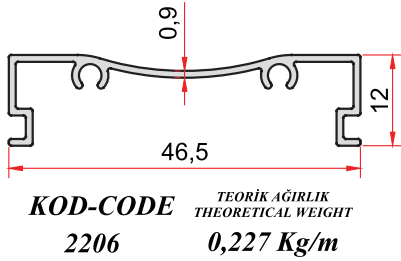
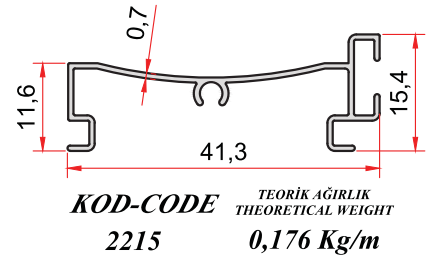
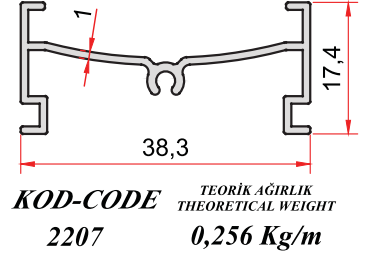
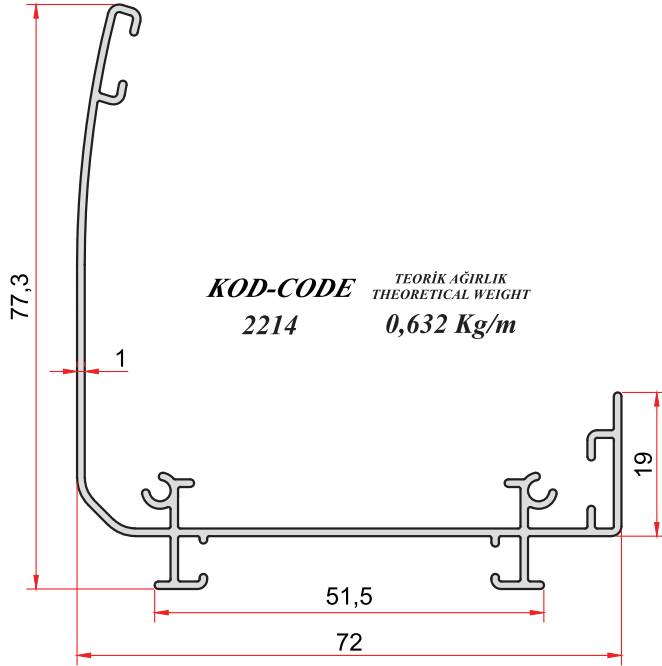

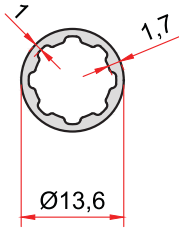

**KOD-CODE** 2217  
**TEORİK AĞIRLIK**  
THEORETICAL WEIGHT  
0,140 Kg/m

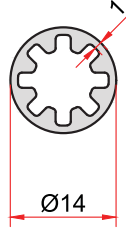

**KOD-CODE** 2202  
**TEORİK AĞIRLIK**  
THEORETICAL WEIGHT  
0,194 Kg/m

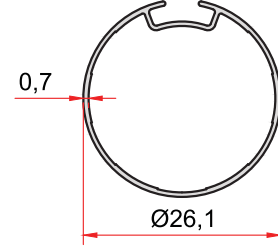

**KOD-CODE** 2216  
**TEORİK AĞIRLIK**  
THEORETICAL WEIGHT  
0,151 Kg/m

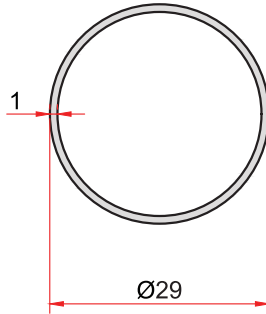

**KOD-CODE** 2220  
**TEORİK AĞIRLIK**  
THEORETICAL WEIGHT  
0,237 Kg/m

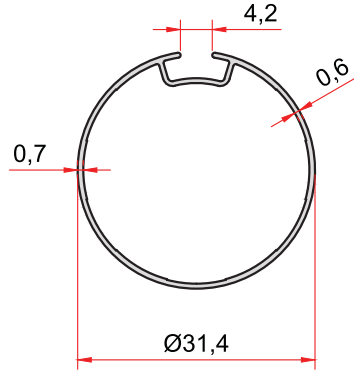

**KOD-CODE** 2201  
**TEORİK AĞIRLIK**  
THEORETICAL WEIGHT  
0,203 Kg/m

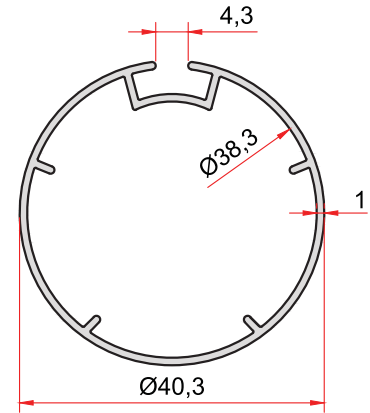

**KOD-CODE** 2213  
**TEORİK AĞIRLIK**  
THEORETICAL WEIGHT  
0,397 Kg/m

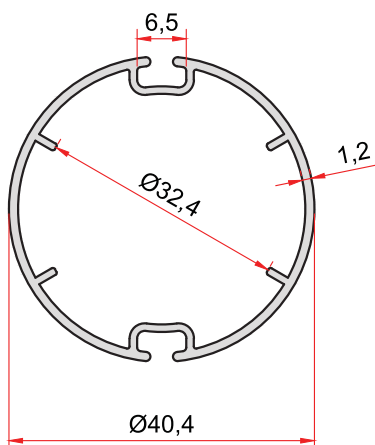

**KOD-CODE** 2209  
**TEORİK AĞIRLIK**  
THEORETICAL WEIGHT  
0,475 Kg/m

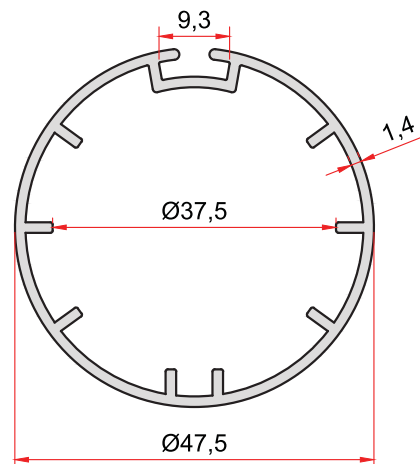

**KOD-CODE** 2210  
**TEORİK AĞIRLIK**  
THEORETICAL WEIGHT  
0,697 Kg/m





**ARFEM**<sup>®</sup>  
ALÜMİNYUM  
Cam Balkon Profilleri



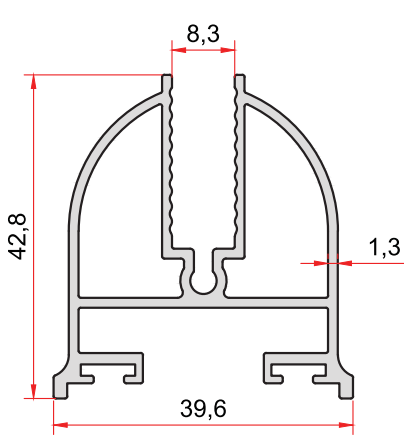

**KOD-CODE** TEORİK AĞIRLIK  
THEORETICAL WEIGHT  
**2251 0,775 Kg/m**

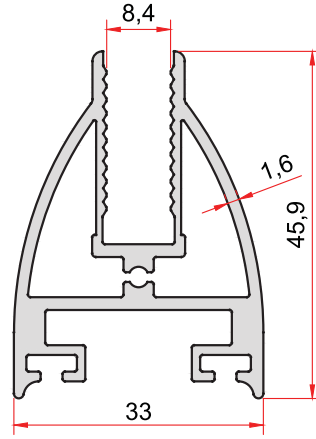

**KOD-CODE** TEORİK AĞIRLIK  
THEORETICAL WEIGHT  
**2257 0,921 Kg/m**

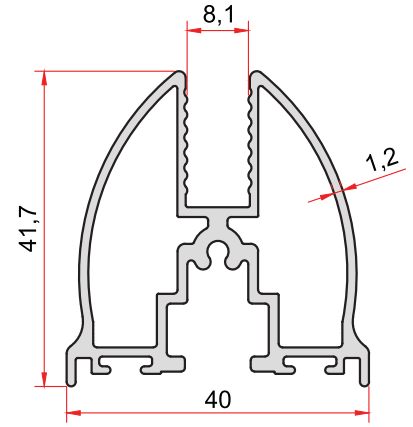

**KOD-CODE** TEORİK AĞIRLIK  
THEORETICAL WEIGHT  
**2261 0,805 Kg/m**

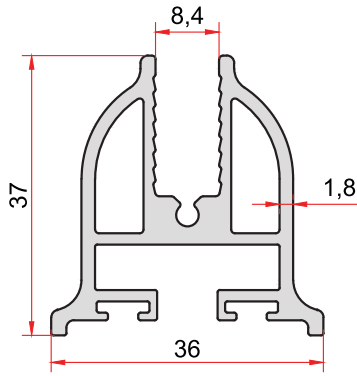

**KOD-CODE** TEORİK AĞIRLIK  
THEORETICAL WEIGHT  
**2269 0,875 Kg/m**

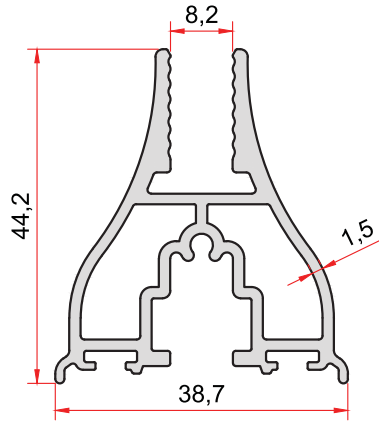

**KOD-CODE** TEORİK AĞIRLIK  
THEORETICAL WEIGHT  
**2291 0,888 Kg/m**

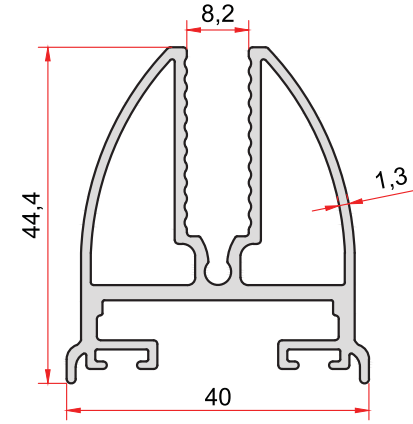

**KOD-CODE** TEORİK AĞIRLIK  
THEORETICAL WEIGHT  
**2292 0,923 Kg/m**

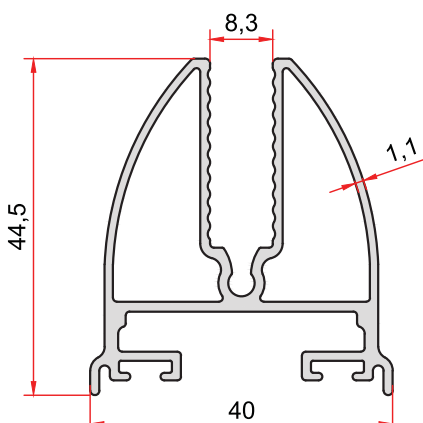

**KOD-CODE** TEORİK AĞIRLIK  
THEORETICAL WEIGHT  
**2718 0,781 Kg/m**

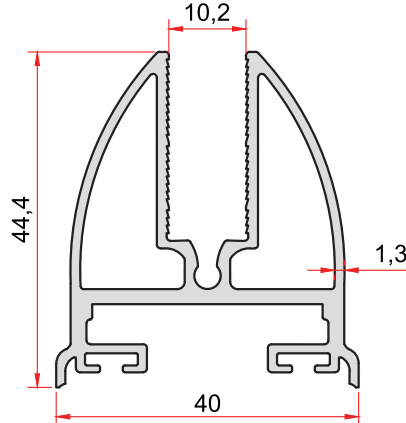

**KOD-CODE** TEORİK AĞIRLIK  
THEORETICAL WEIGHT  
**2374 0,923 Kg/m**

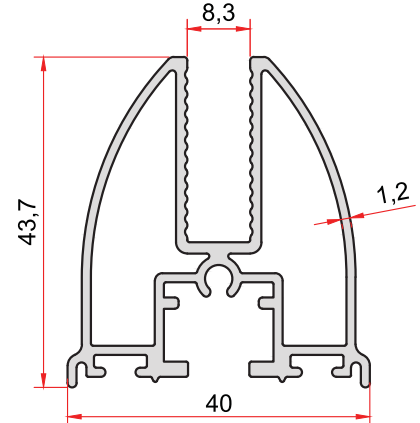

**KOD-CODE** TEORİK AĞIRLIK  
THEORETICAL WEIGHT  
**2637 0,847 Kg/m**

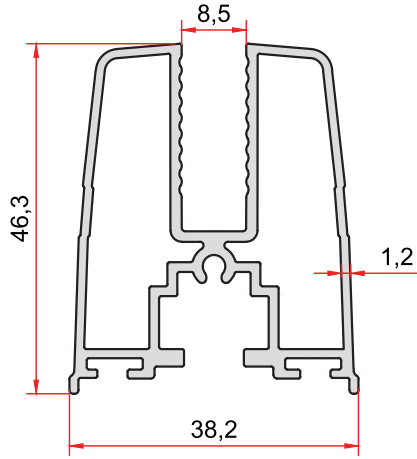

**KOD-CODE** *TEORİK AĞIRLIK*  
**2753** *THEORETICAL WEIGHT*  
**0,888 Kg/m**

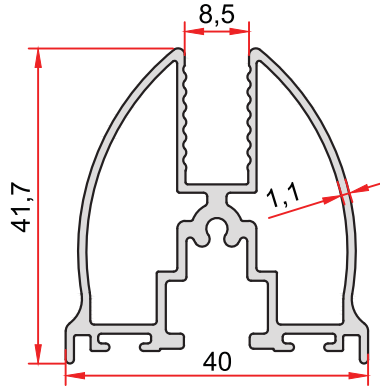

**KOD-CODE** *TEORİK AĞIRLIK*  
**2620** *THEORETICAL WEIGHT*  
**0,753 Kg/m**

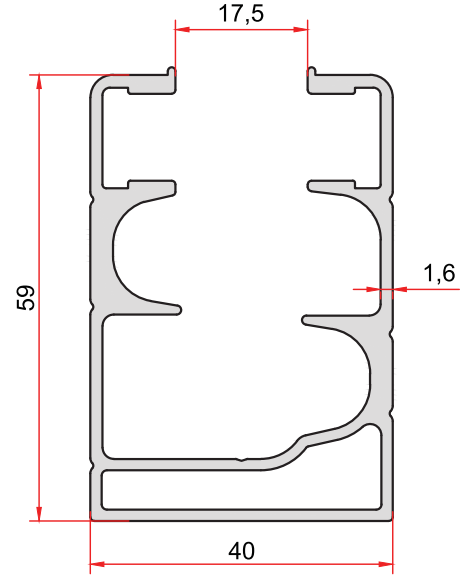

**KOD-CODE** *TEORİK AĞIRLIK*  
**2717** *THEORETICAL WEIGHT*  
**1,279 Kg/m**

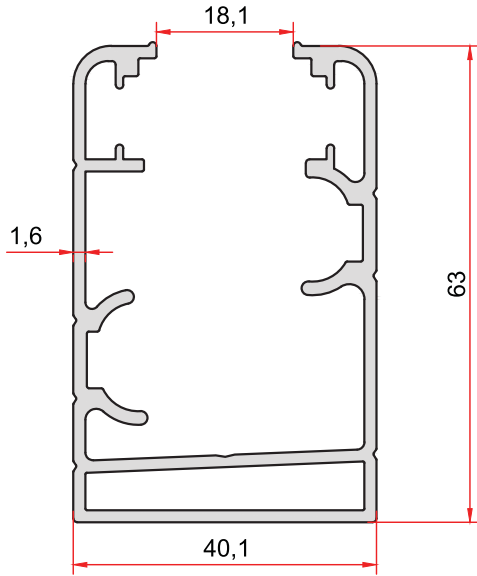

**KOD-CODE** *TEORİK AĞIRLIK*  
**2680** *THEORETICAL WEIGHT*  
**1,231 Kg/m**

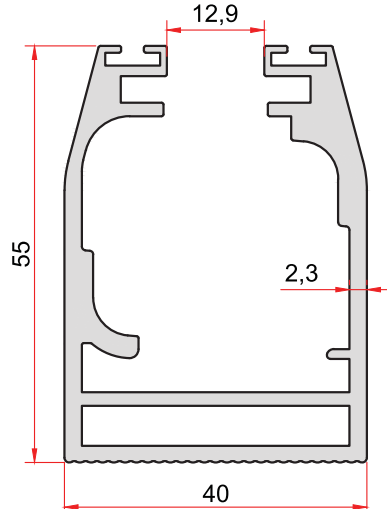

**KOD-CODE** *TEORİK AĞIRLIK*  
**2255** *THEORETICAL WEIGHT*  
**1,477 Kg/m**

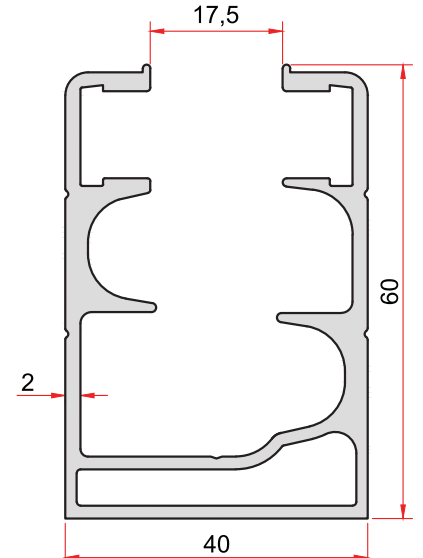

**KOD-CODE** *TEORİK AĞIRLIK*  
**2293** *THEORETICAL WEIGHT*  
**1,393 Kg/m**

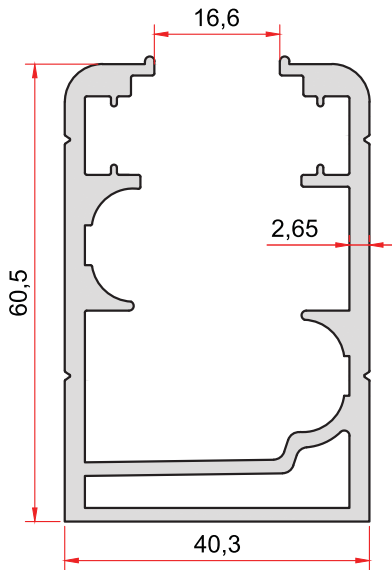

**KOD-CODE** *TEORİK AĞIRLIK*  
**2263** *THEORETICAL WEIGHT*  
**1,569 Kg/m**

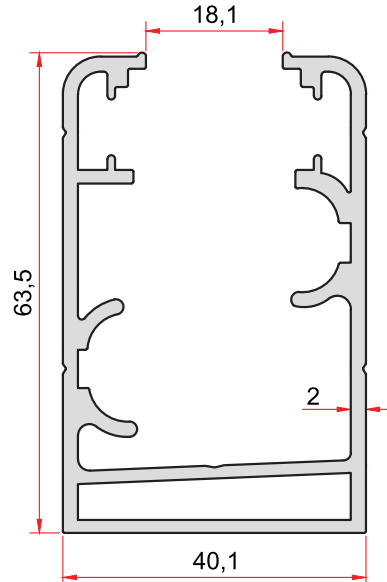

**KOD-CODE** *TEORİK AĞIRLIK*  
**2260** *THEORETICAL WEIGHT*  
**1,396 Kg/m**

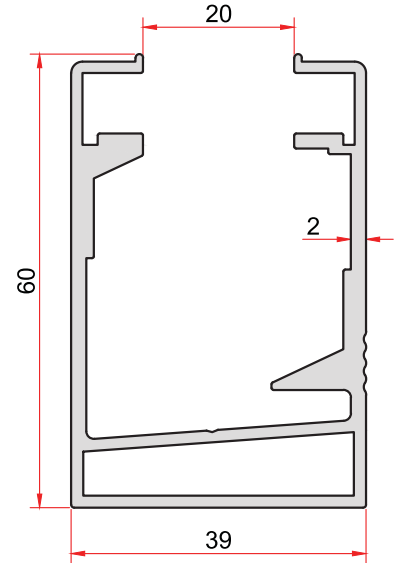

**KOD-CODE** *TEORİK AĞIRLIK*  
**2295** *THEORETICAL WEIGHT*  
**1,242 Kg/m**

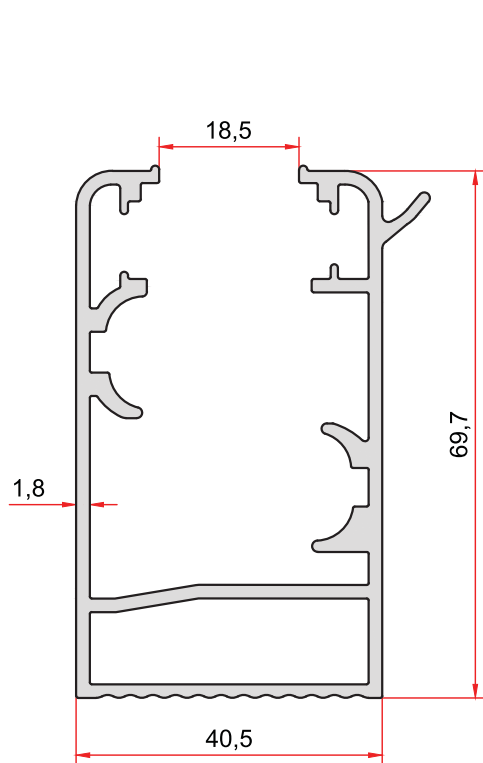

**KOD-CODE** *TEORİK AĞIRLIK*  
**2752** *THEORETICAL WEIGHT*  
**1,441 Kg/m**

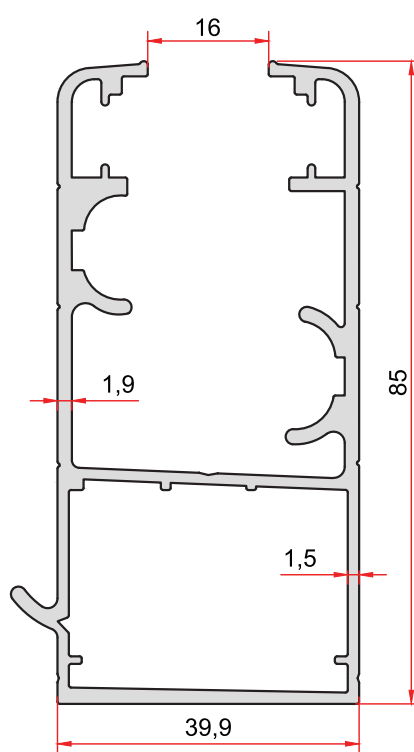

**KOD-CODE** *TEORİK AĞIRLIK*  
**2729** *THEORETICAL WEIGHT*  
**1,585 Kg/m**

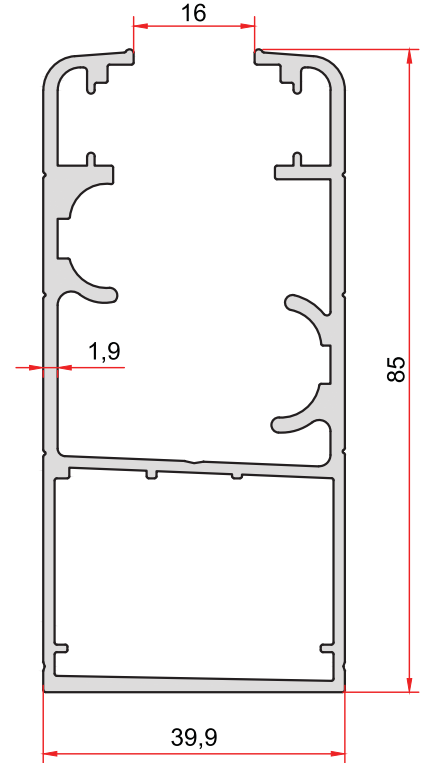

**KOD-CODE** *TEORİK AĞIRLIK*  
**2730** *THEORETICAL WEIGHT*  
**1,547 Kg/m**



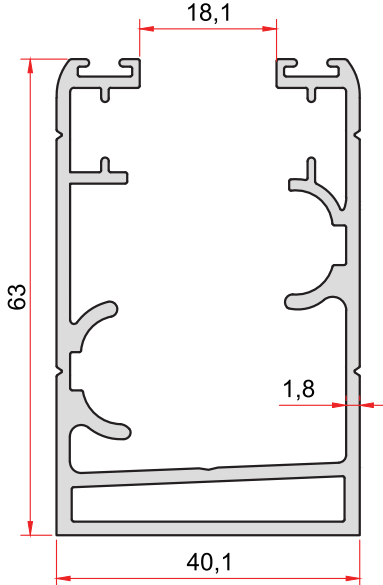

**KOD-CODE** *TEORİK AĞIRLIK*  
*THEORETICAL WEIGHT*  
**2371** **1,328 Kg/m**

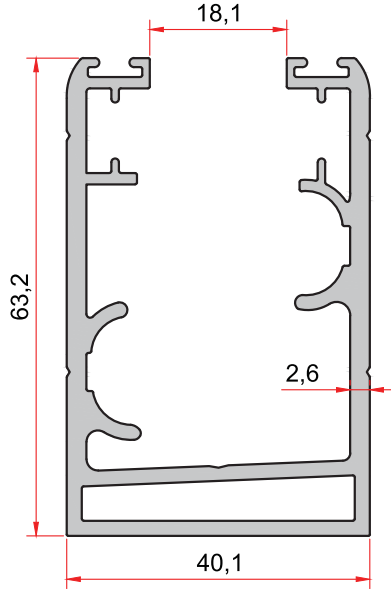

**KOD-CODE** *TEORİK AĞIRLIK*  
*THEORETICAL WEIGHT*  
**2448** **1,563 Kg/m**

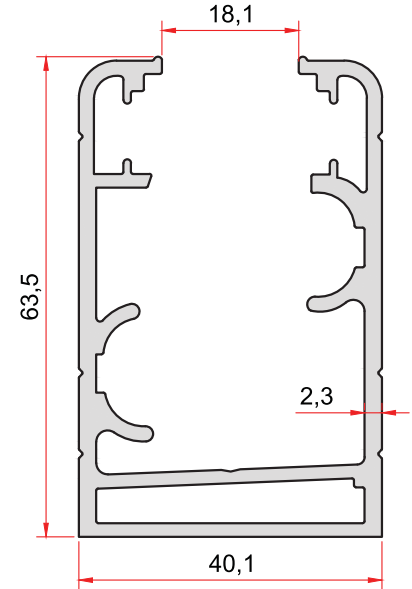

**KOD-CODE** *TEORİK AĞIRLIK*  
*THEORETICAL WEIGHT*  
**2393** **1,477 Kg/m**

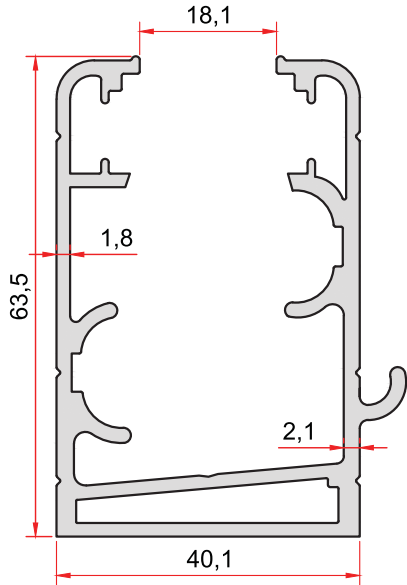

**KOD-CODE** *TEORİK AĞIRLIK*  
*THEORETICAL WEIGHT*  
**2268** **1,477 Kg/m**

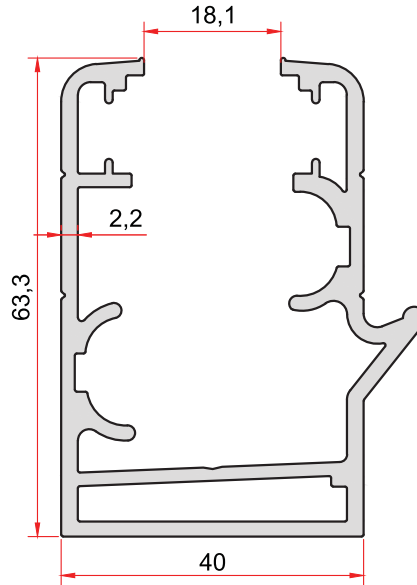

**KOD-CODE** *TEORİK AĞIRLIK*  
*THEORETICAL WEIGHT*  
**2272** **1,545 Kg/m**

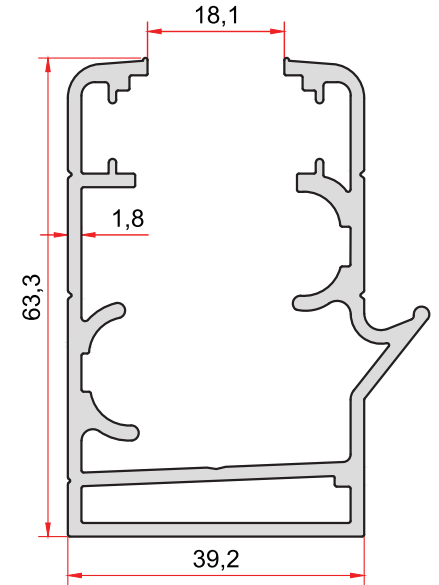

**KOD-CODE** *TEORİK AĞIRLIK*  
*THEORETICAL WEIGHT*  
**2653** **1,393 Kg/m**

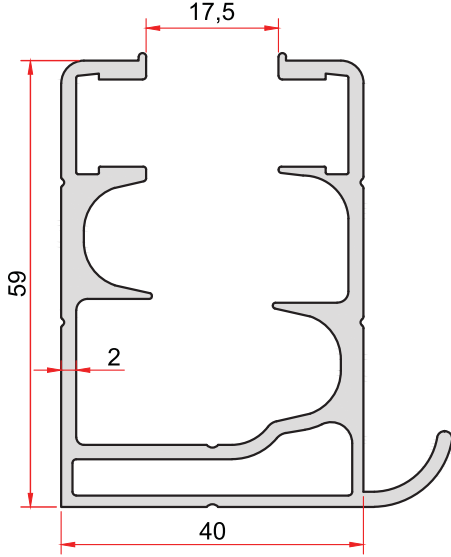

**KOD-CODE** *TEORİK AĞIRLIK*  
*THEORETICAL WEIGHT*  
**2372** **1,458 Kg/m**

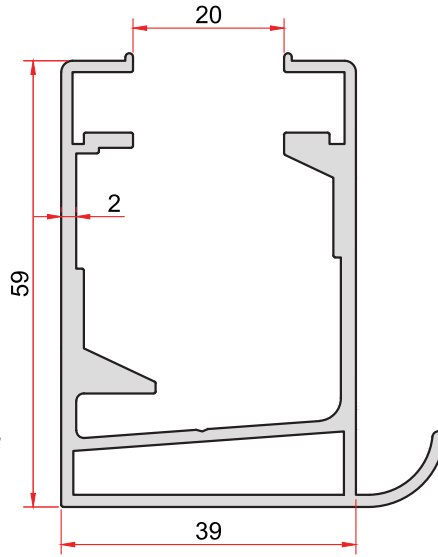

**KOD-CODE** *TEORİK AĞIRLIK*  
*THEORETICAL WEIGHT*  
**2373** **1,334 Kg/m**

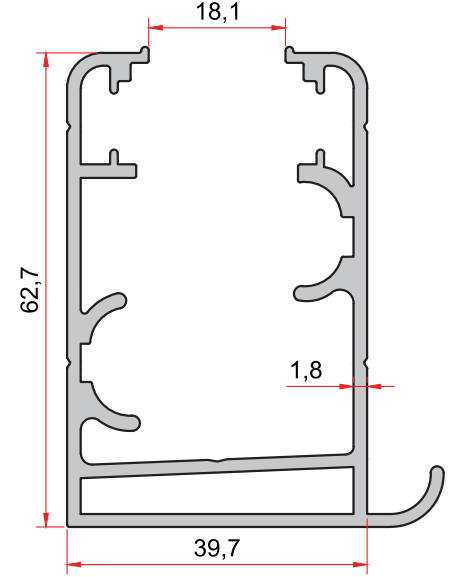

**KOD-CODE** *TEORİK AĞIRLIK*  
*THEORETICAL WEIGHT*  
**2450** **1,378 Kg/m**

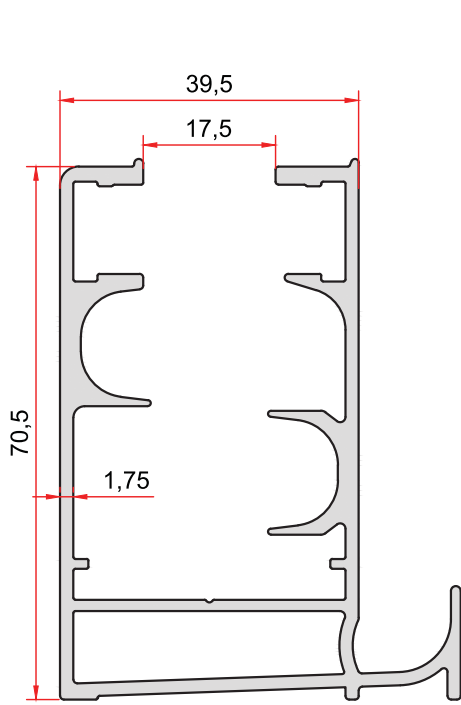

**KOD-CODE** *TEORİK AĞIRLIK*  
*THEORETICAL WEIGHT*  
**2662** **1,574 Kg/m**

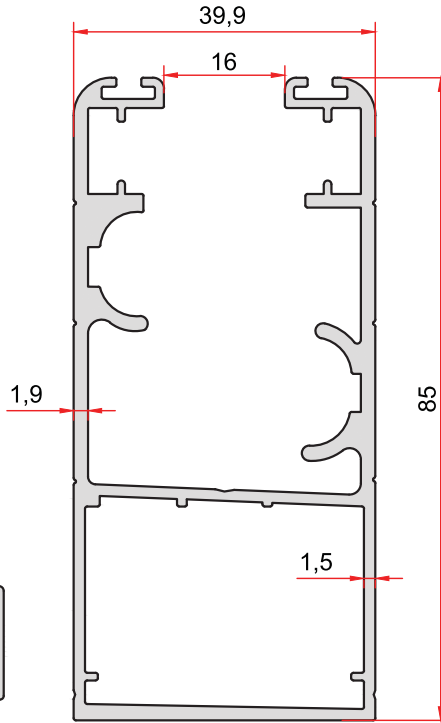

**KOD-CODE** *TEORİK AĞIRLIK*  
*THEORETICAL WEIGHT*  
**2727** **1,558 Kg/m**

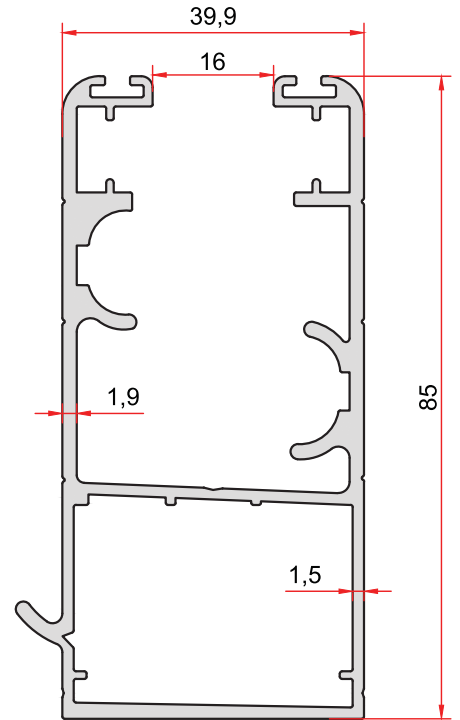

**KOD-CODE** *TEORİK AĞIRLIK*  
*THEORETICAL WEIGHT*  
**2728** **1,596 Kg/m**

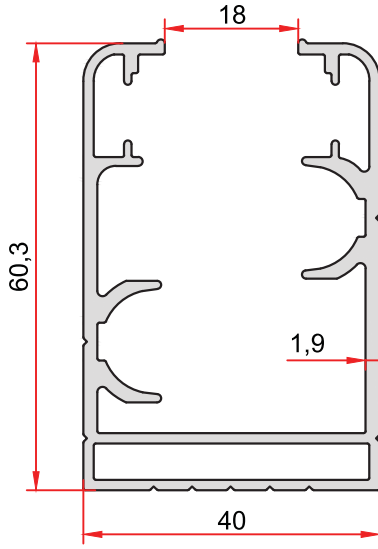

**KOD-CODE**  
**2762**  
TEORİK AĞIRLIK  
THEORETICAL WEIGHT  
**1,163 Kg/m**

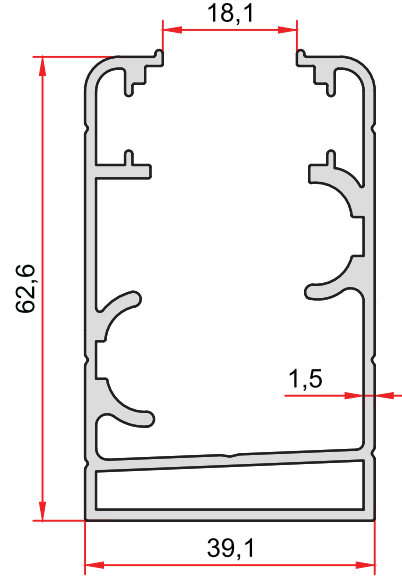

**KOD-CODE**  
**2621**  
TEORİK AĞIRLIK  
THEORETICAL WEIGHT  
**1,169 Kg/m**

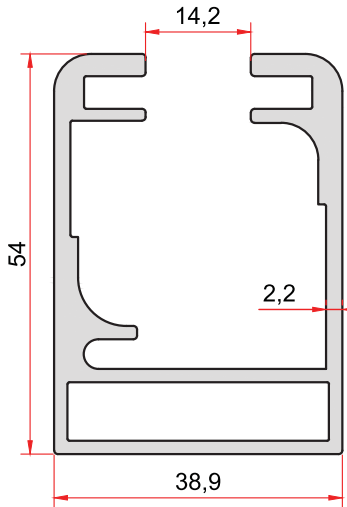

**KOD-CODE**  
**2270**  
TEORİK AĞIRLIK  
THEORETICAL WEIGHT  
**1,404 Kg/m**

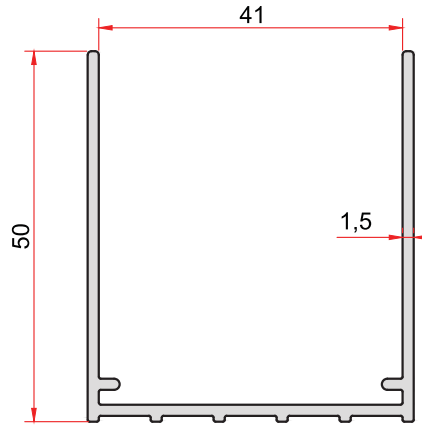

**KOD-CODE**  
**2636**  
TEORİK AĞIRLIK  
THEORETICAL WEIGHT  
**0,605 Kg/m**

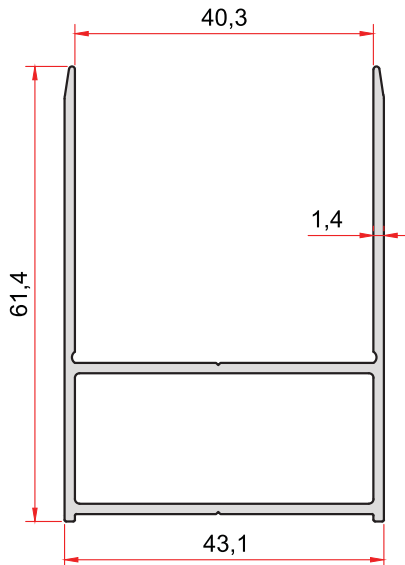

**KOD-CODE**  
**2267**  
TEORİK AĞIRLIK  
THEORETICAL WEIGHT  
**0,759 Kg/m**

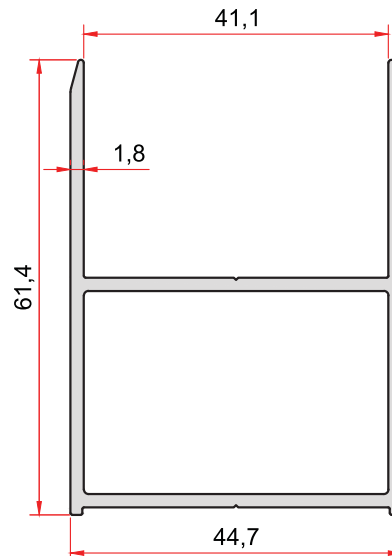

**KOD-CODE**  
**2253**  
TEORİK AĞIRLIK  
THEORETICAL WEIGHT  
**0,983 Kg/m**

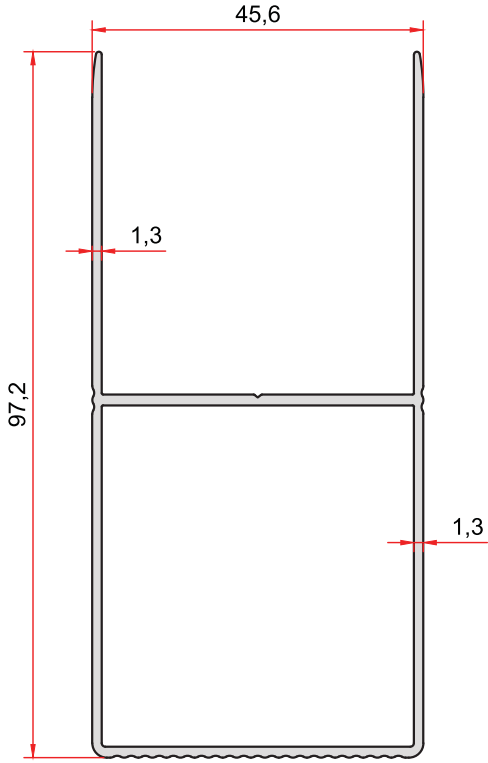

**KOD-CODE** TEORİK AĞIRLIK  
THEORETICAL WEIGHT  
**2666** **1,002 Kg/m**

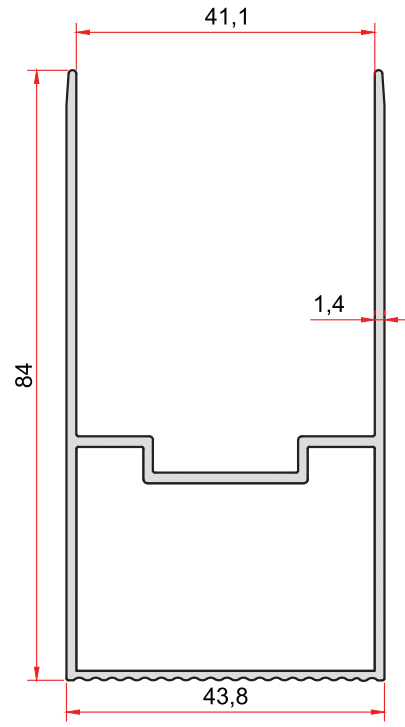

**KOD-CODE** TEORİK AĞIRLIK  
THEORETICAL WEIGHT  
**2274** **0,929 Kg/m**

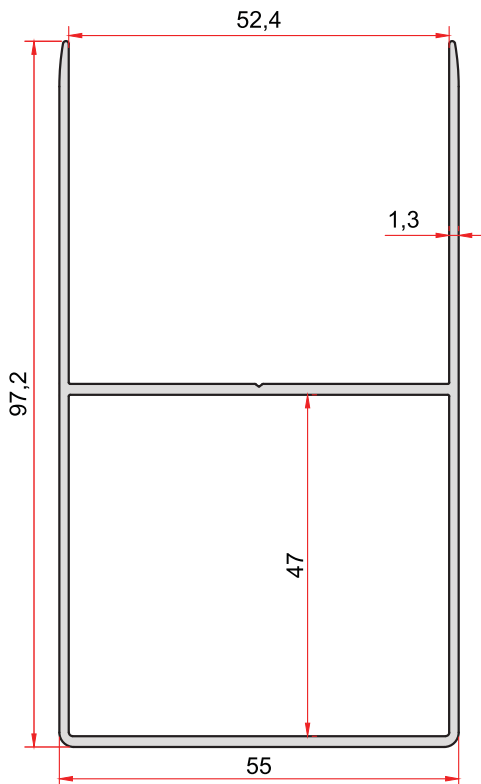

**KOD-CODE** TEORİK AĞIRLIK  
THEORETICAL WEIGHT  
**2630** **1,096 Kg/m**

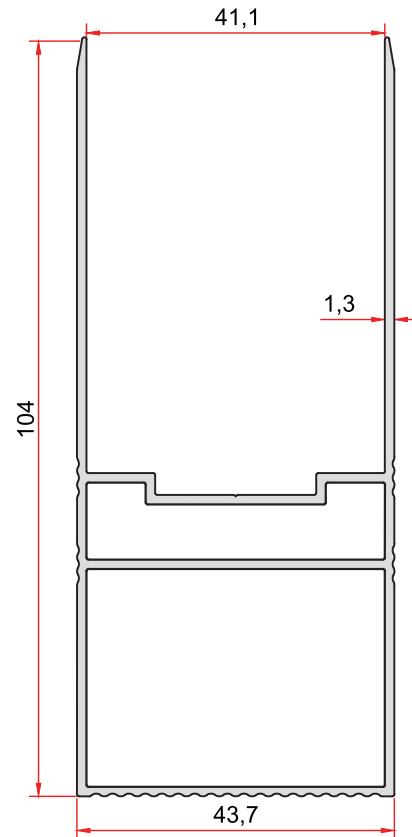

**KOD-CODE** TEORİK AĞIRLIK  
THEORETICAL WEIGHT  
**2663** **1,150 Kg/m**

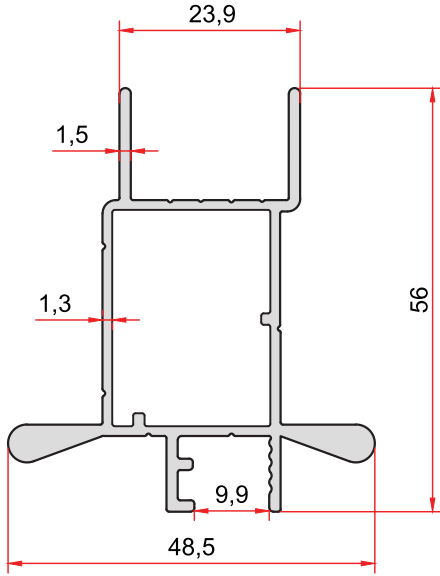

**KOD-CODE** *TEORİK AĞIRLIK*  
*THEORETICAL WEIGHT*  
**2724** **0,829 Kg/m**

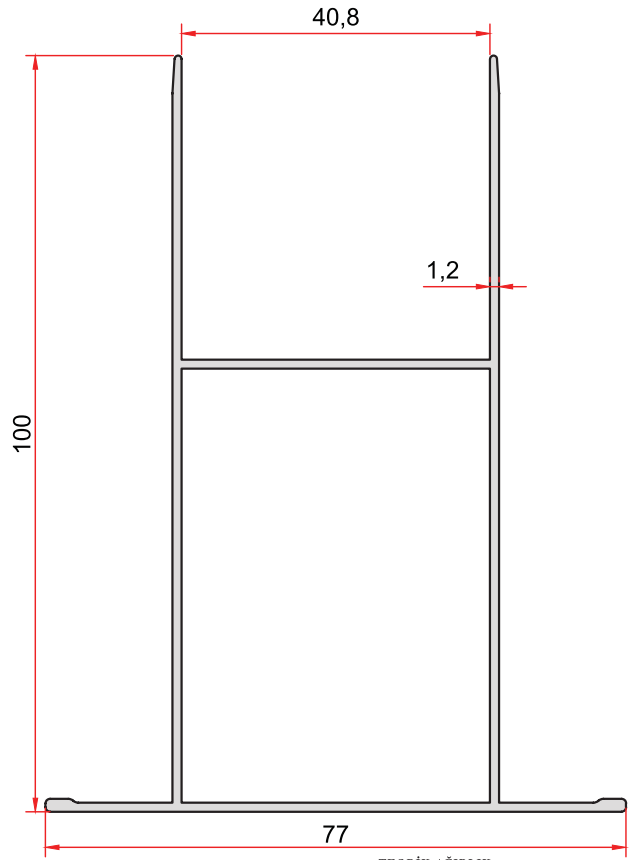

**KOD-CODE** *TEORİK AĞIRLIK*  
*THEORETICAL WEIGHT*  
**2618** **1,026 Kg/m**

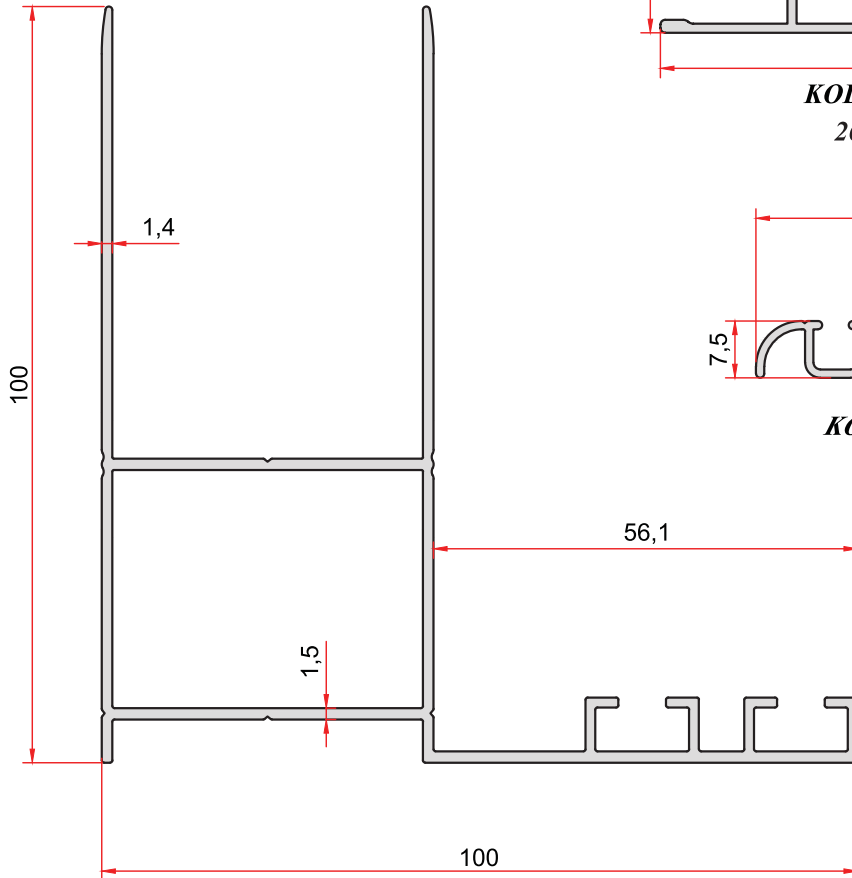

**KOD-CODE** *TEORİK AĞIRLIK*  
*THEORETICAL WEIGHT*  
**2736** **1,447 Kg/m**

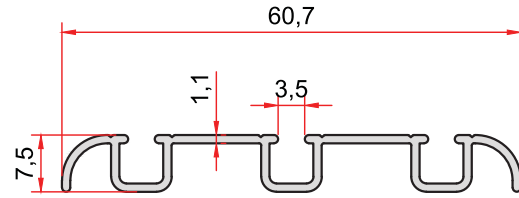

**KOD-CODE** *TEORİK AĞIRLIK*  
*THEORETICAL WEIGHT*  
**2697** **0,324 Kg/m**

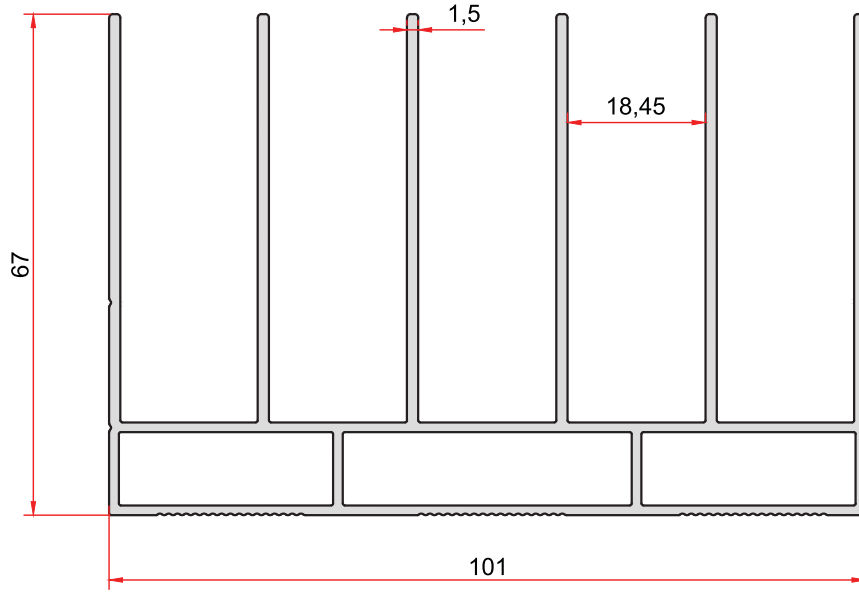

**KOD-CODE** *TEORİK AĞIRLIK*  
*THEORETICAL WEIGHT*  
**2734** **2,152 Kg/m**

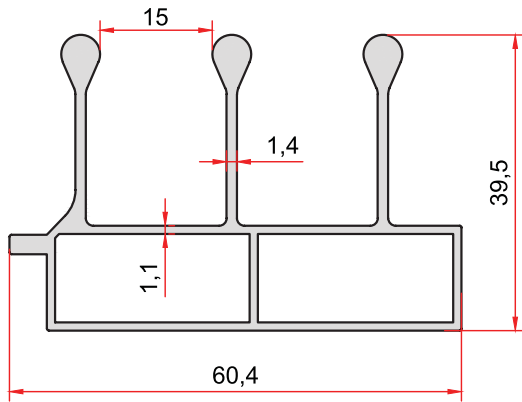

**KOD-CODE** *TEORİK AĞIRLIK*  
*THEORETICAL WEIGHT*  
**2698** **0,910 Kg/m**

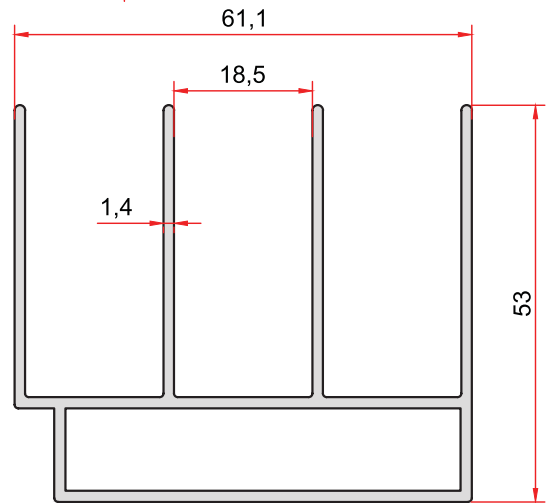

**KOD-CODE** *TEORİK AĞIRLIK*  
*THEORETICAL WEIGHT*  
**2699** **1,150 Kg/m**

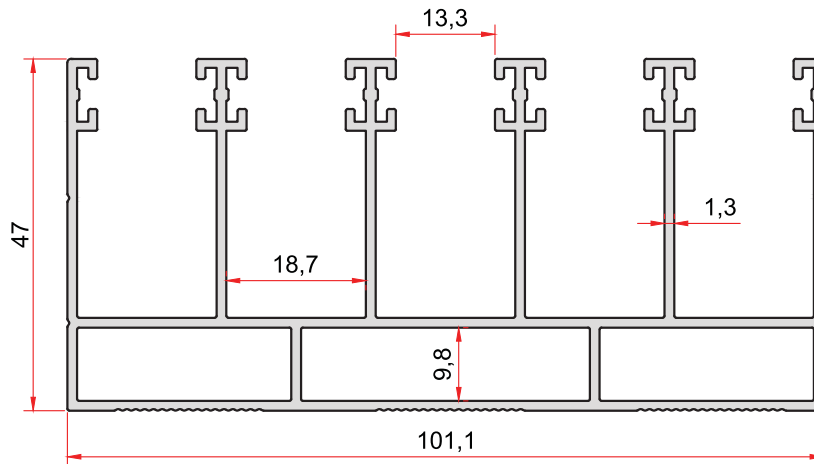

**KOD-CODE** *TEORİK AĞIRLIK*  
*THEORETICAL WEIGHT*  
**2617** **1,847 Kg/m**

# Cam Balkon Profilleri

**ARFEM**<sup>®</sup>  
ALÜMİNYUM

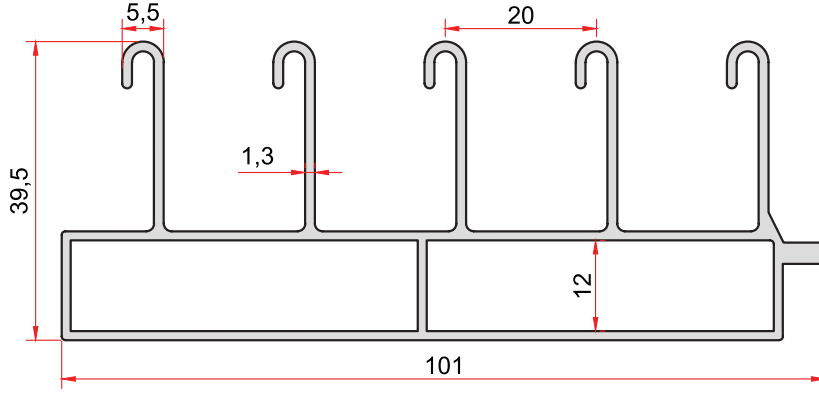

**KOD-CODE** *TEORİK AĞIRLIK*  
2623 *THEORETICAL WEIGHT*  
1,350 Kg/m

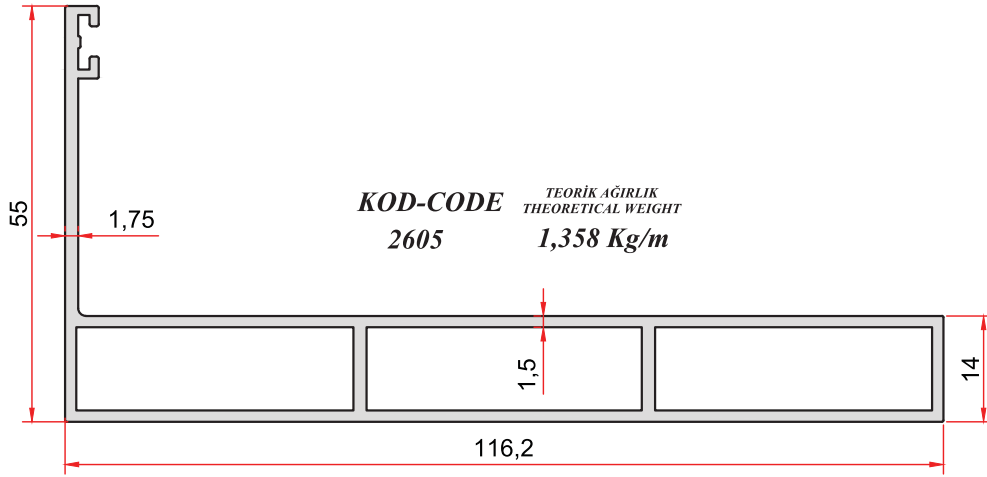

**KOD-CODE** *TEORİK AĞIRLIK*  
2605 *THEORETICAL WEIGHT*  
1,358 Kg/m

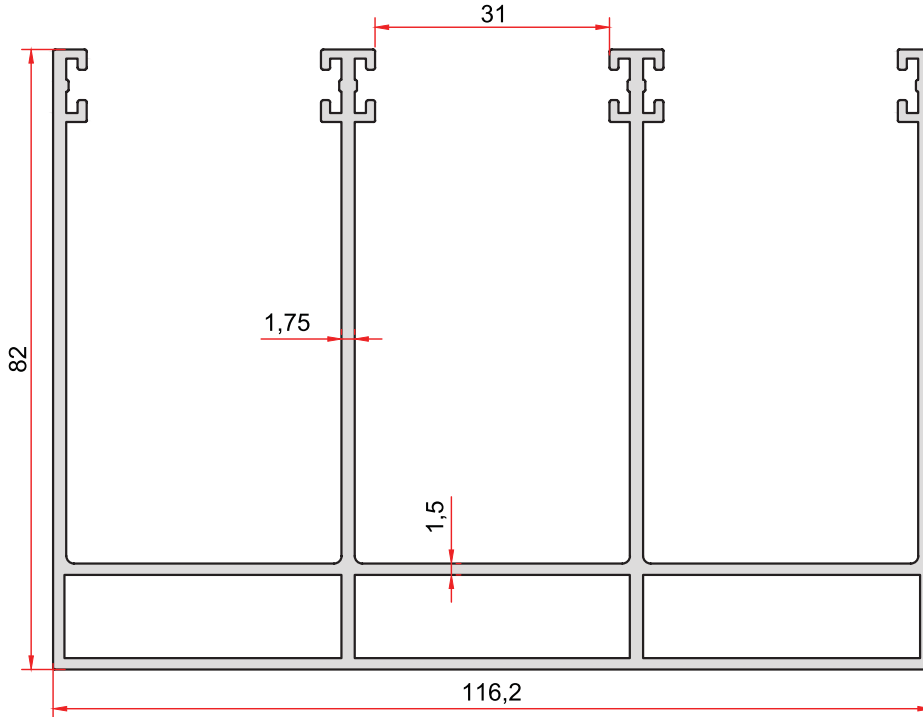

**KOD-CODE** *TEORİK AĞIRLIK*  
2604 *THEORETICAL WEIGHT*  
2,595 Kg/m

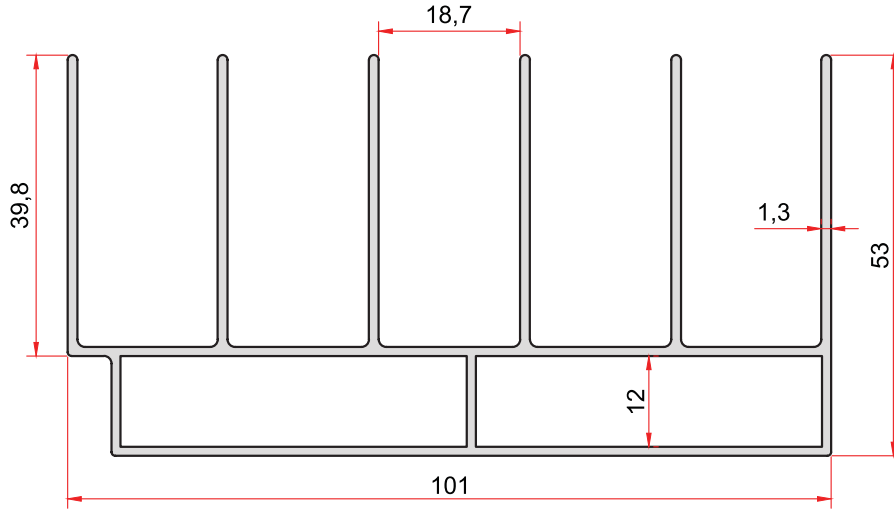

**KOD-CODE**      **TEORİK AĞIRLIK**  
**2622**              **THEORETICAL WEIGHT**  
                                 **1,568 Kg/m**

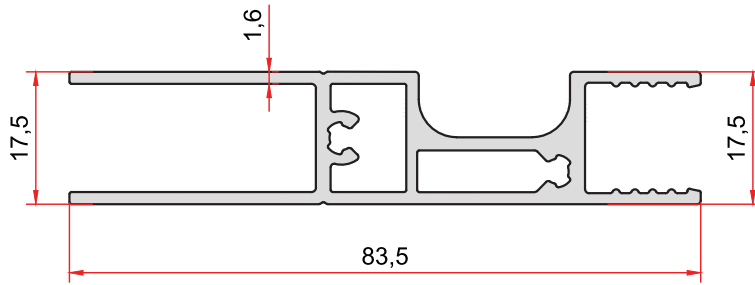

**KOD-CODE**      **TEORİK AĞIRLIK**  
**2735**              **THEORETICAL WEIGHT**  
                                 **1,028 Kg/m**

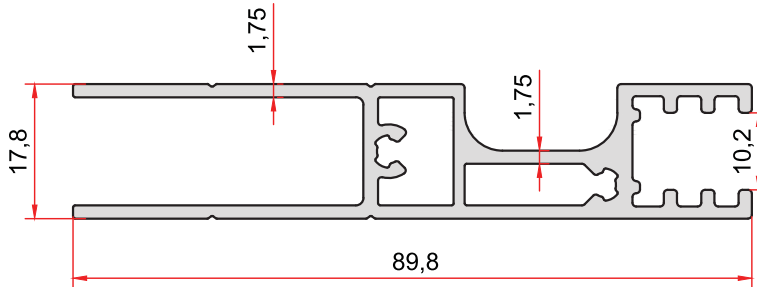

**KOD-CODE**      **TEORİK AĞIRLIK**  
**2719**              **THEORETICAL WEIGHT**  
                                 **1,196 Kg/m**

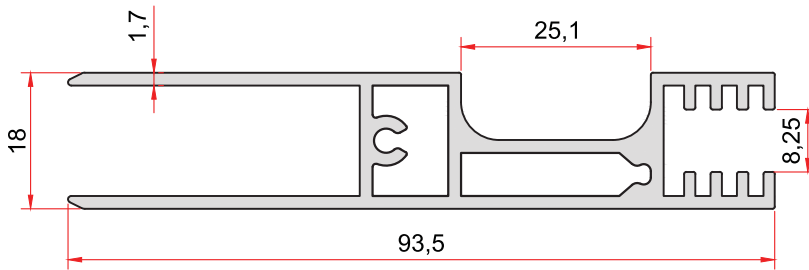

**KOD-CODE**      **TEORİK AĞIRLIK**  
**2624**              **THEORETICAL WEIGHT**  
                                 **1,255 Kg/m**

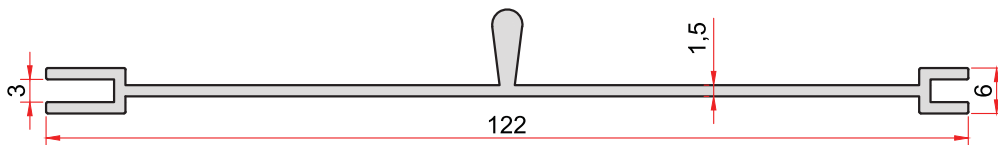

**KOD-CODE**      **TEORİK AĞIRLIK**  
**2601**              **THEORETICAL WEIGHT**  
                                 **0,669 Kg/m**



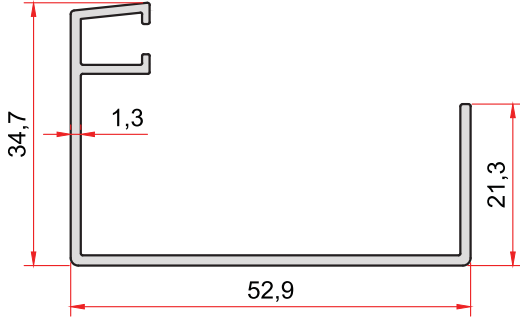

**KOD-CODE** TEORİK AĞIRLIK  
2252 0,451 Kg/m  
THEORETICAL WEIGHT

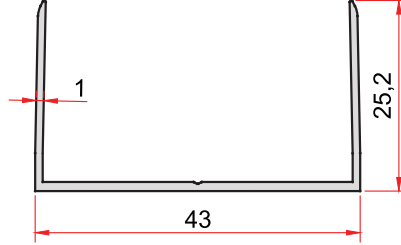

**KOD-CODE** TEORİK AĞIRLIK  
2297 0,265 Kg/m  
THEORETICAL WEIGHT

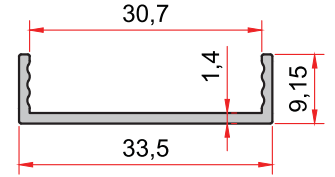

**KOD-CODE** TEORİK AĞIRLIK  
2449 0,181 Kg/m  
THEORETICAL WEIGHT

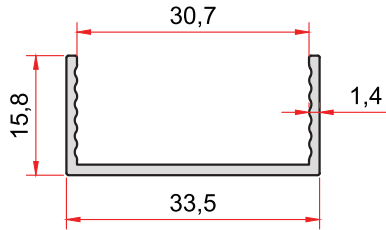

**KOD-CODE** TEORİK AĞIRLIK  
2627 0,224 Kg/m  
THEORETICAL WEIGHT

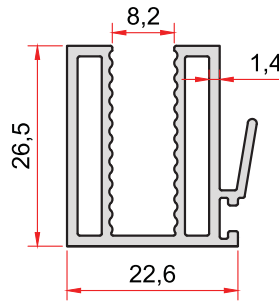

**KOD-CODE** TEORİK AĞIRLIK  
2388 0,507 Kg/m  
THEORETICAL WEIGHT

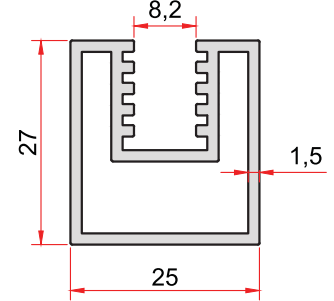

**KOD-CODE** TEORİK AĞIRLIK  
2602 0,575 Kg/m  
THEORETICAL WEIGHT

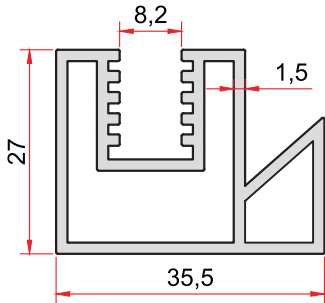

**KOD-CODE** TEORİK AĞIRLIK  
2603 0,732 Kg/m  
THEORETICAL WEIGHT

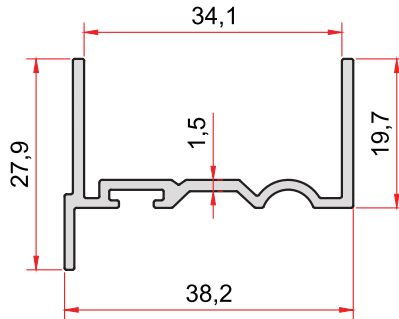

**KOD-CODE** TEORİK AĞIRLIK  
2626 0,356 Kg/m  
THEORETICAL WEIGHT

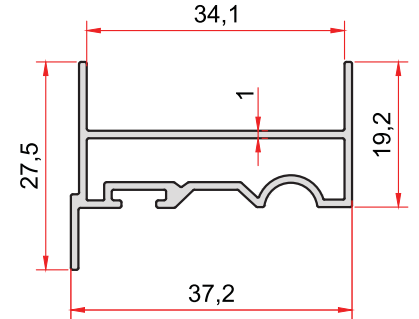

**KOD-CODE** TEORİK AĞIRLIK  
2299 0,354 Kg/m  
THEORETICAL WEIGHT

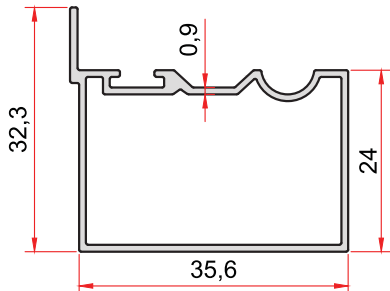

**KOD-CODE** TEORİK AĞIRLIK  
2300 0,343 Kg/m  
THEORETICAL WEIGHT

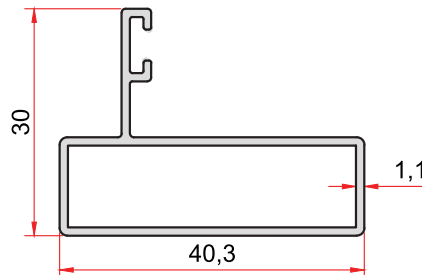

**KOD-CODE** TEORİK AĞIRLIK  
2256 0,378 Kg/m  
THEORETICAL WEIGHT

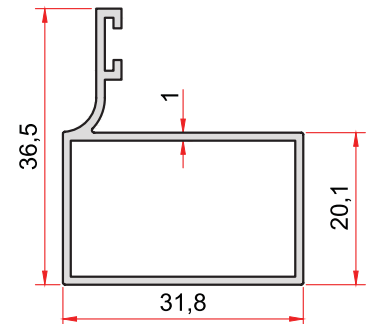

**KOD-CODE** TEORİK AĞIRLIK  
2262 0,359 Kg/m  
THEORETICAL WEIGHT

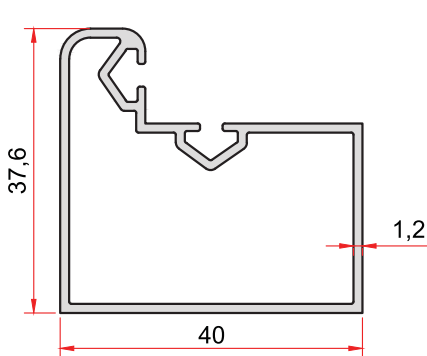

**KOD-CODE** *TEORİK AĞIRLIK*  
*THEORETICAL WEIGHT*  
**2294** **0,540 Kg/m**

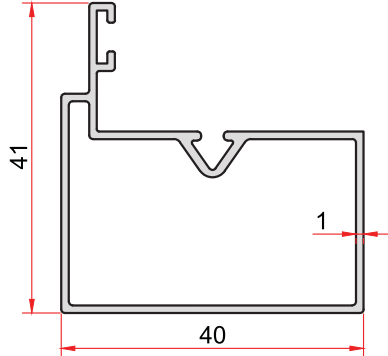

**KOD-CODE** *TEORİK AĞIRLIK*  
*THEORETICAL WEIGHT*  
**2296** **0,448 Kg/m**

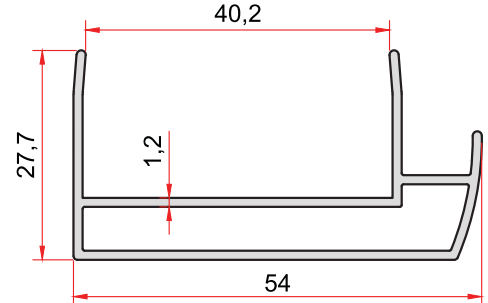

**KOD-CODE** *TEORİK AĞIRLIK*  
*THEORETICAL WEIGHT*  
**2392** **0,532 Kg/m**

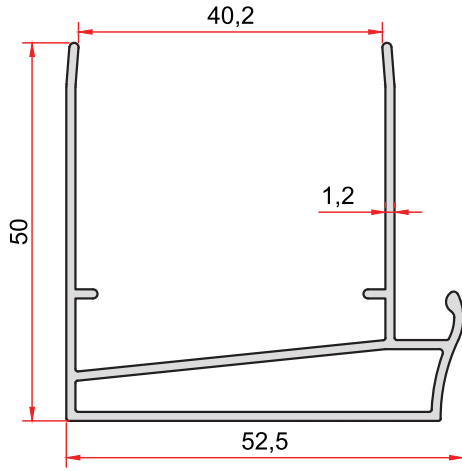

**KOD-CODE** *TEORİK AĞIRLIK*  
*THEORETICAL WEIGHT*  
**2664** **0,680 Kg/m**

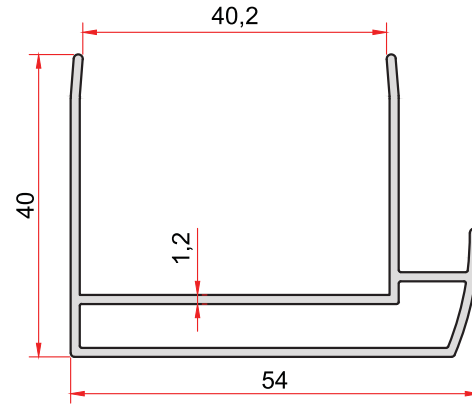

**KOD-CODE** *TEORİK AĞIRLIK*  
*THEORETICAL WEIGHT*  
**2619** **0,610 Kg/m**

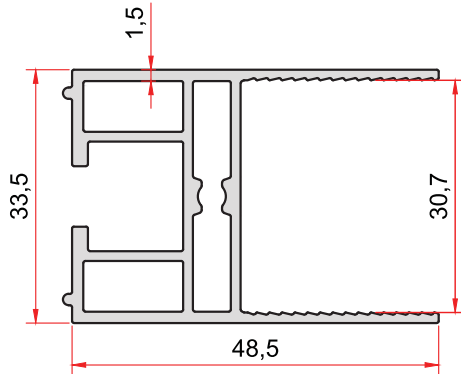

**KOD-CODE** *TEORİK AĞIRLIK*  
*THEORETICAL WEIGHT*  
**2370** **0,802 Kg/m**

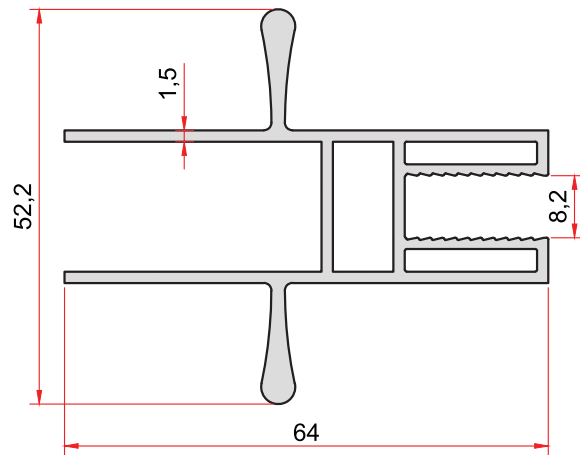

**KOD-CODE** *TEORİK AĞIRLIK*  
*THEORETICAL WEIGHT*  
**2389** **1,064 Kg/m**

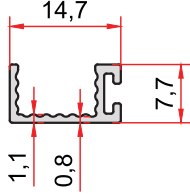

**KOD-CODE** 2720 **TEORİK AĞIRLIK** 0,092 **THEORETICAL WEIGHT** Kg/m

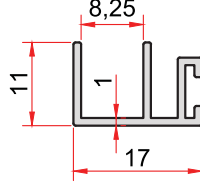

**KOD-CODE** 2625 **TEORİK AĞIRLIK** 0,135 **THEORETICAL WEIGHT** Kg/m

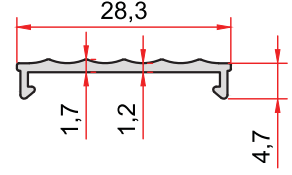

**KOD-CODE** 2696 **TEORİK AĞIRLIK** 0,125 **THEORETICAL WEIGHT** Kg/m

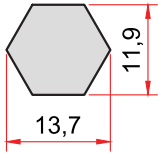

**KOD-CODE** 2273 **TEORİK AĞIRLIK** 0,332 **THEORETICAL WEIGHT** Kg/m

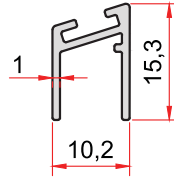

**KOD-CODE** 2391 **TEORİK AĞIRLIK** 0,116 **THEORETICAL WEIGHT** Kg/m

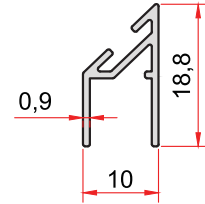

**KOD-CODE** 2264 **TEORİK AĞIRLIK** 0,113 **THEORETICAL WEIGHT** Kg/m

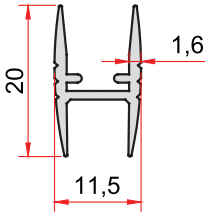

**KOD-CODE** 2258 **TEORİK AĞIRLIK** 0,162 **THEORETICAL WEIGHT** Kg/m

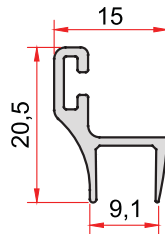

**KOD-CODE** 2259 **TEORİK AĞIRLIK** 0,167 **THEORETICAL WEIGHT** Kg/m

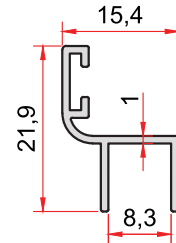

**KOD-CODE** 2266 **TEORİK AĞIRLIK** 0,140 **THEORETICAL WEIGHT** Kg/m

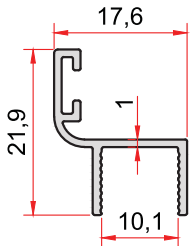

**KOD-CODE** 2377 **TEORİK AĞIRLIK** 0,151 **THEORETICAL WEIGHT** Kg/m

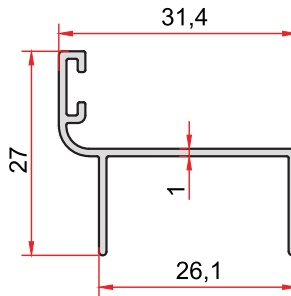

**KOD-CODE** 2757 **TEORİK AĞIRLIK** 0,208 **THEORETICAL WEIGHT** Kg/m

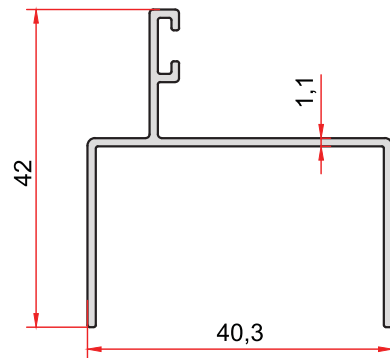

**KOD-CODE** 2667 **TEORİK AĞIRLIK** 0,337 **THEORETICAL WEIGHT** Kg/m

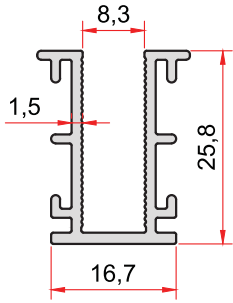

**KOD-CODE** *TEORİK AĞIRLIK*  
**2390** *THEORETICAL WEIGHT*  
**0,345 Kg/m**

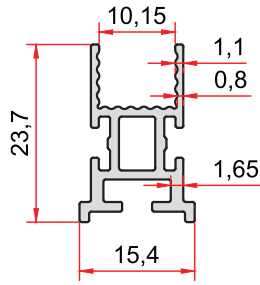

**KOD-CODE** *TEORİK AĞIRLIK*  
**2722** *THEORETICAL WEIGHT*  
**0,267 Kg/m**

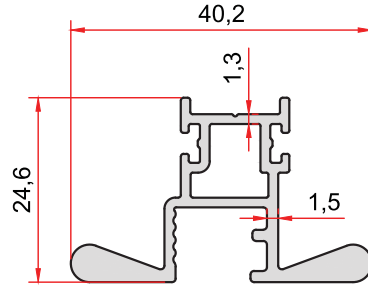

**KOD-CODE** *TEORİK AĞIRLIK*  
**2723** *THEORETICAL WEIGHT*  
**0,545 Kg/m**

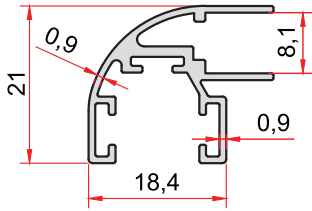

**KOD-CODE** *TEORİK AĞIRLIK*  
**2265** *THEORETICAL WEIGHT*  
**0,265 Kg/m**

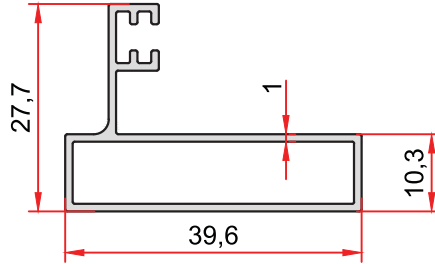

**KOD-CODE** *TEORİK AĞIRLIK*  
**2763** *THEORETICAL WEIGHT*  
**0,356 Kg/m**

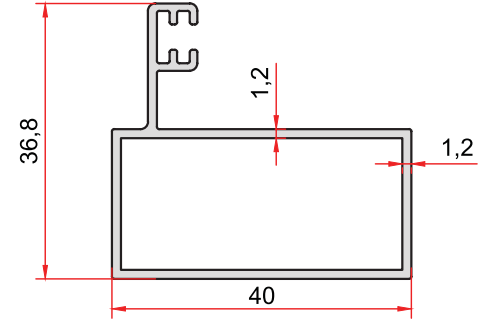

**KOD-CODE** *TEORİK AĞIRLIK*  
**2726** *THEORETICAL WEIGHT*  
**0,472 Kg/m**

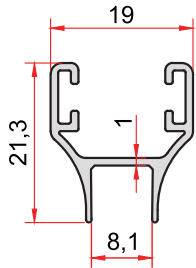

**KOD-CODE** *TEORİK AĞIRLIK*  
**1429** *THEORETICAL WEIGHT*  
**0,197 Kg/m**

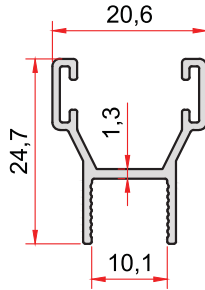

**KOD-CODE** *TEORİK AĞIRLIK*  
**2376** *THEORETICAL WEIGHT*  
**0,224 Kg/m**

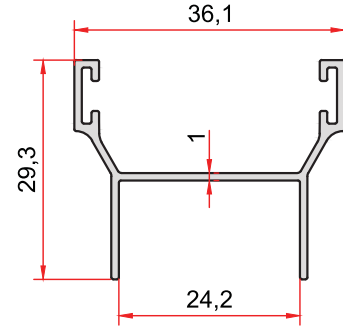

**KOD-CODE** *TEORİK AĞIRLIK*  
**2759** *THEORETICAL WEIGHT*  
**0,272 Kg/m**

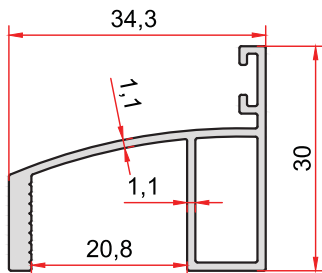

**KOD-CODE** *TEORİK AĞIRLIK*  
**2750** *THEORETICAL WEIGHT*  
**0,383 Kg/m**

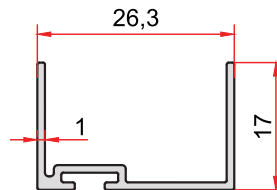

**KOD-CODE** *TEORİK AĞIRLIK*  
**2758** *THEORETICAL WEIGHT*  
**0,180 Kg/m**

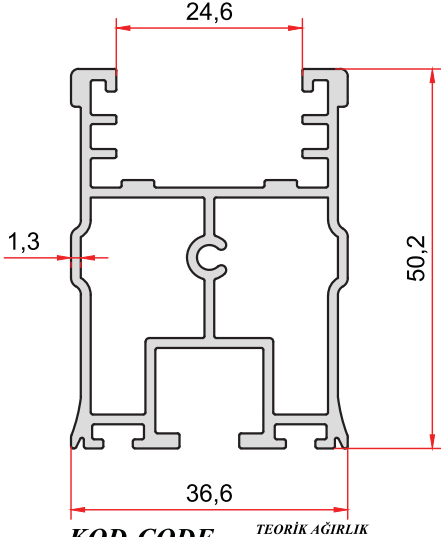

**KOD-CODE** *TEORİK AĞIRLIK*  
**2751** *THEORETICAL WEIGHT*  
**0,980 Kg/m**

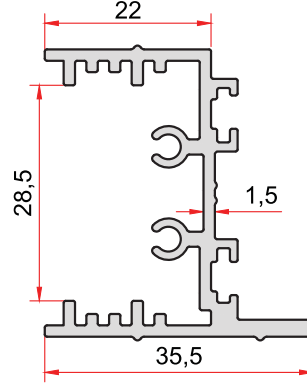

**KOD-CODE** *TEORİK AĞIRLIK*  
**2632** *THEORETICAL WEIGHT*  
**0,656 Kg/m**

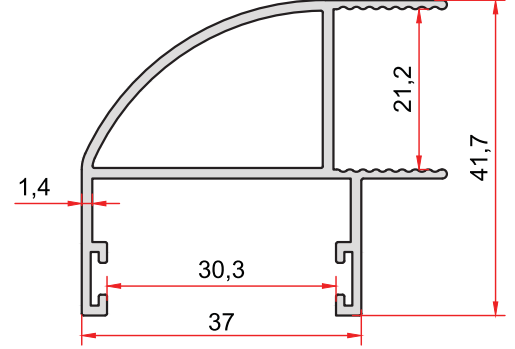

**KOD-CODE** *TEORİK AĞIRLIK*  
**2668** *THEORETICAL WEIGHT*  
**0,621 Kg/m**

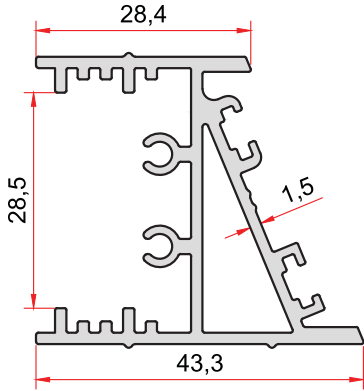

**KOD-CODE** *TEORİK AĞIRLIK*  
**2633** *THEORETICAL WEIGHT*  
**0,843 Kg/m**

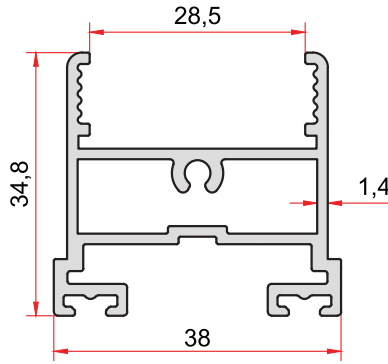

**KOD-CODE** *TEORİK AĞIRLIK*  
**2634** *THEORETICAL WEIGHT*  
**0,726 Kg/m**

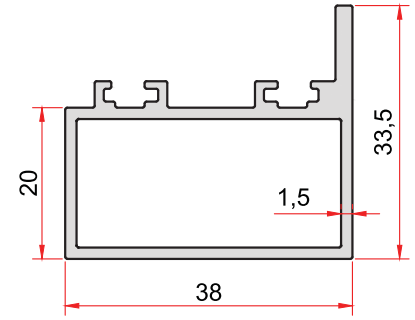

**KOD-CODE** *TEORİK AĞIRLIK*  
**2635** *THEORETICAL WEIGHT*  
**0,613 Kg/m**

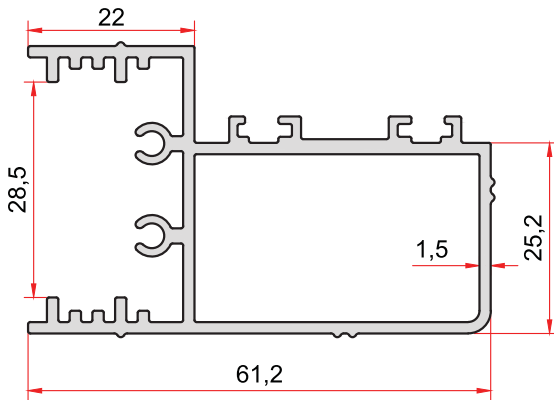

**KOD-CODE** *TEORİK AĞIRLIK*  
**2631** *THEORETICAL WEIGHT*  
**0,726 Kg/m**

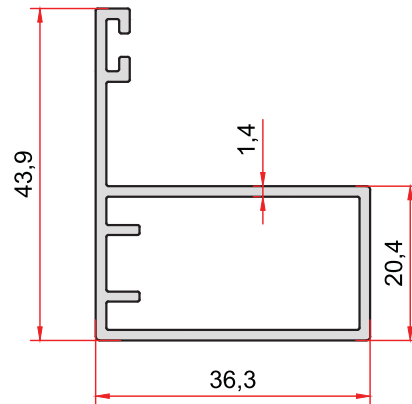

**KOD-CODE** *TEORİK AĞIRLIK*  
**2756** *THEORETICAL WEIGHT*  
**0,564 Kg/m**

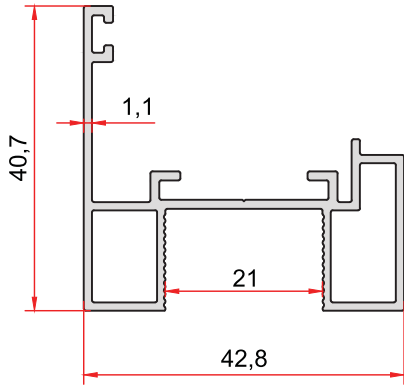

**KOD-CODE** *TEORİK AĞIRLIK*  
2732 *THEORETICAL WEIGHT*  
0,529 Kg/m

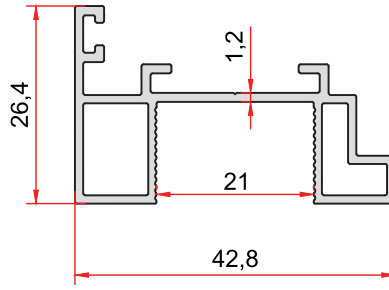

**KOD-CODE** *TEORİK AĞIRLIK*  
2733 *THEORETICAL WEIGHT*  
0,443 Kg/m

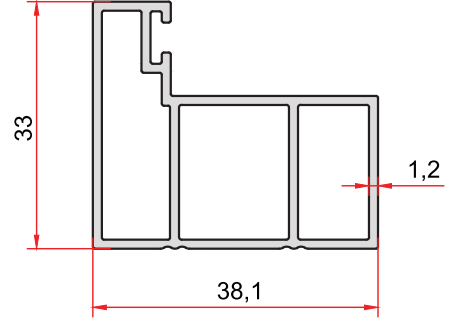

**KOD-CODE** *TEORİK AĞIRLIK*  
2731 *THEORETICAL WEIGHT*  
0,578 Kg/m

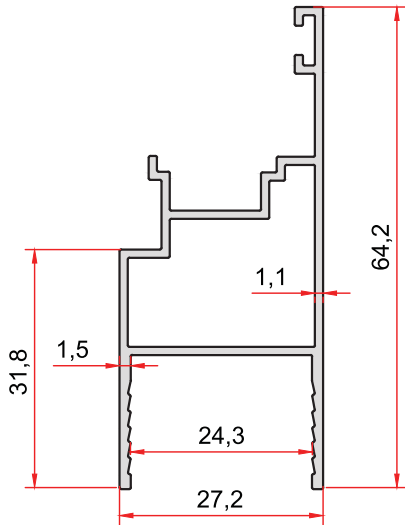

**KOD-CODE** *TEORİK AĞIRLIK*  
2754 *THEORETICAL WEIGHT*  
0,545 Kg/m

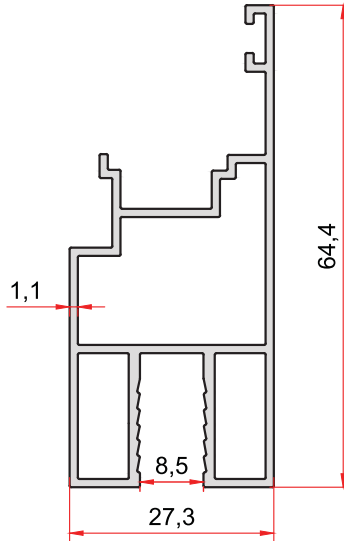

**KOD-CODE** *TEORİK AĞIRLIK*  
7042 *THEORETICAL WEIGHT*  
0,696 Kg/m

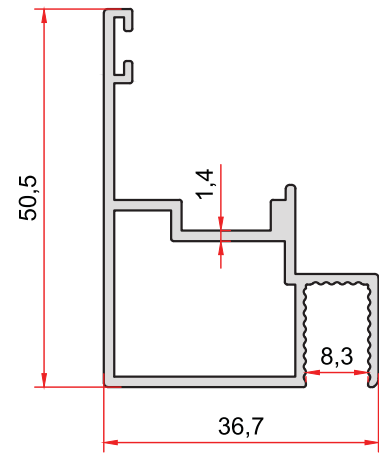

**KOD-CODE** *TEORİK AĞIRLIK*  
2681 *THEORETICAL WEIGHT*  
0,610 Kg/m

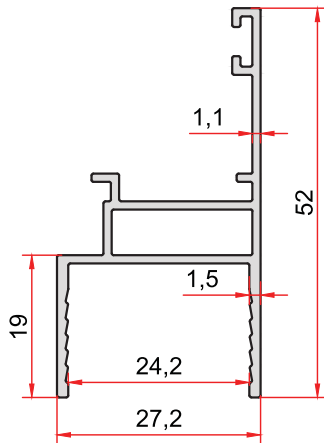

**KOD-CODE** *TEORİK AĞIRLIK*  
2755 *THEORETICAL WEIGHT*  
0,434 Kg/m

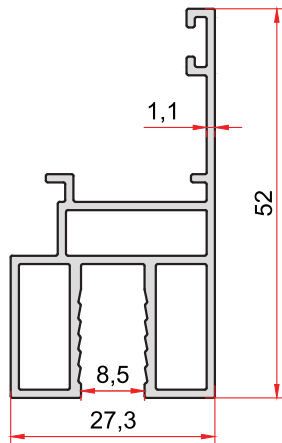

**KOD-CODE** *TEORİK AĞIRLIK*  
7043 *THEORETICAL WEIGHT*  
0,583 Kg/m

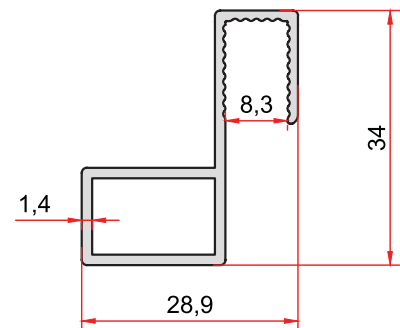

**KOD-CODE** *TEORİK AĞIRLIK*  
2682 *THEORETICAL WEIGHT*  
0,375 Kg/m

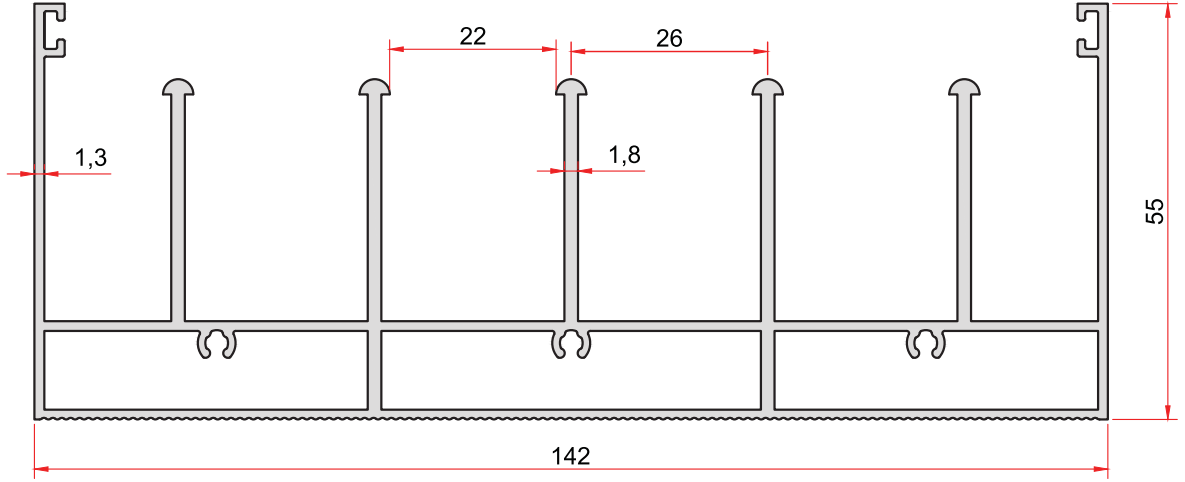

**KOD-CODE** *TEORİK AĞIRLIK*  
*THEORETICAL WEIGHT*  
**2381** **2,349 Kg/m**

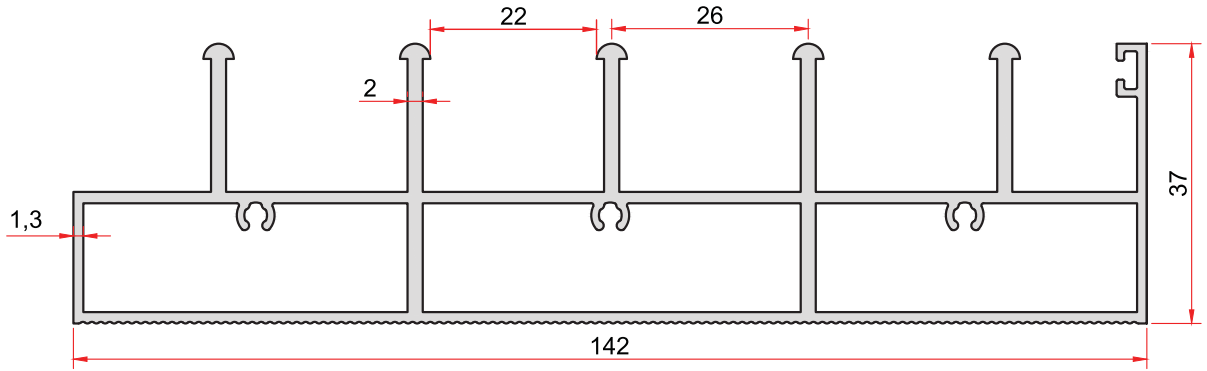

**KOD-CODE** *TEORİK AĞIRLIK*  
*THEORETICAL WEIGHT*  
**2382** **2,084 Kg/m**

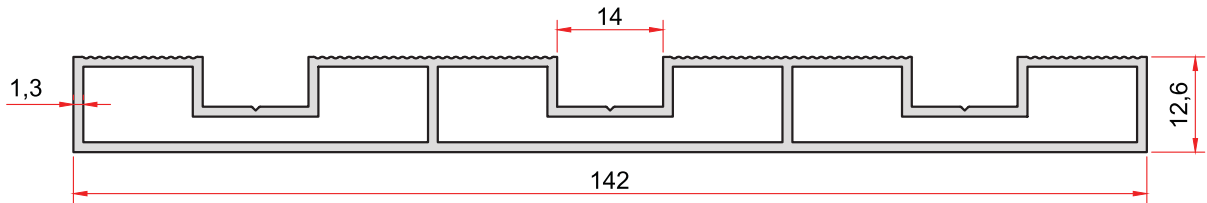

**KOD-CODE** *TEORİK AĞIRLIK*  
*THEORETICAL WEIGHT*  
**2383** **1,247 Kg/m**

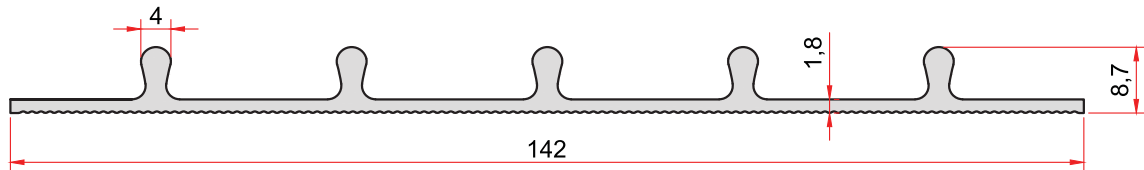

**KOD-CODE** *TEORİK AĞIRLIK*  
*THEORETICAL WEIGHT*  
**2384** **0,955 Kg/m**

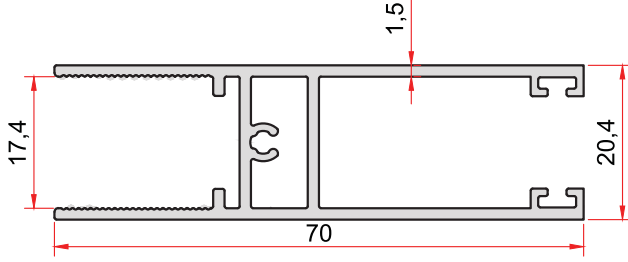

**KOD-CODE** *TEORİK AĞIRLIK*  
**2379** *THEORETICAL WEIGHT*  
**0,783 Kg/m**

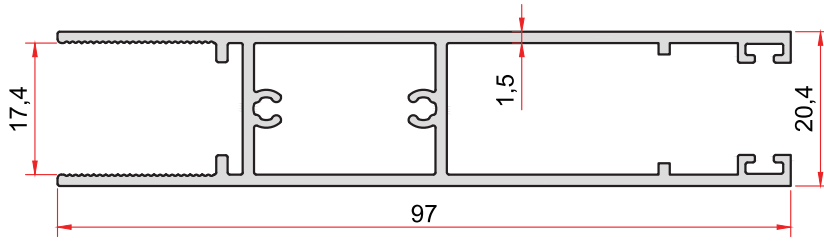

**KOD-CODE** *TEORİK AĞIRLIK*  
**2380** *THEORETICAL WEIGHT*  
**1,036 Kg/m**

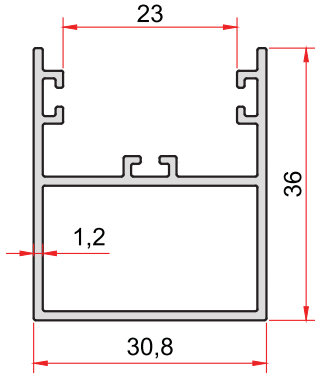

**KOD-CODE** *TEORİK AĞIRLIK*  
**2386** *THEORETICAL WEIGHT*  
**0,480 Kg/m**

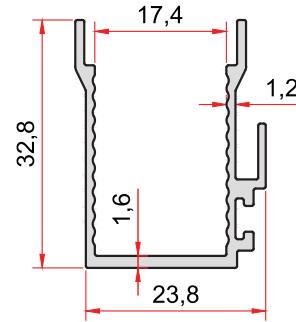

**KOD-CODE** *TEORİK AĞIRLIK*  
**2387** *THEORETICAL WEIGHT*  
**0,340 Kg/m**

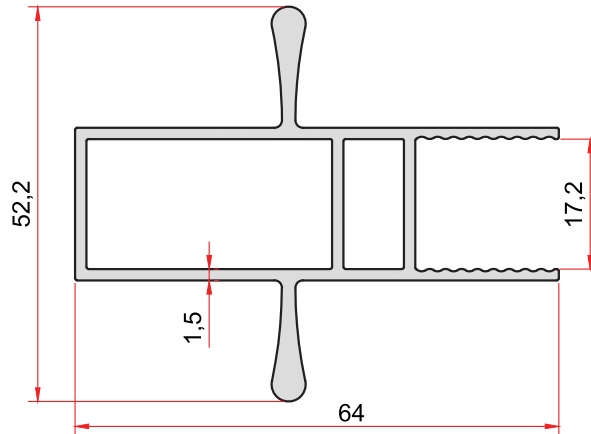

**KOD-CODE** *TEORİK AĞIRLIK*  
**2385** *THEORETICAL WEIGHT*  
**0,956 Kg/m**



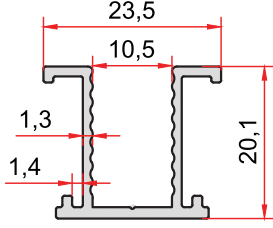

**KOD-CODE** 2683  
**TEORİK AĞIRLIK**  
**THEORETICAL WEIGHT**  
0,251 Kg/m

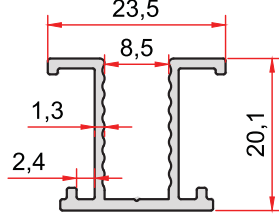

**KOD-CODE** 2679  
**TEORİK AĞIRLIK**  
**THEORETICAL WEIGHT**  
0,256 Kg/m

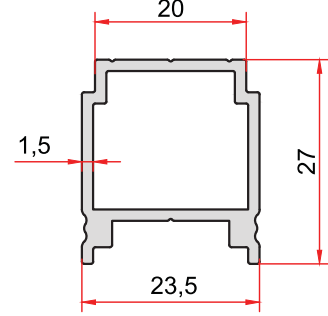

**KOD-CODE** 2678  
**TEORİK AĞIRLIK**  
**THEORETICAL WEIGHT**  
0,421 Kg/m

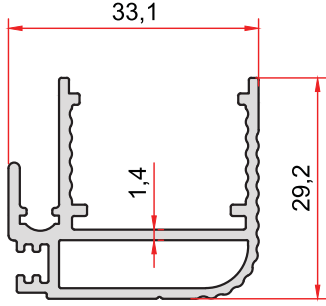

**KOD-CODE** 2677  
**TEORİK AĞIRLIK**  
**THEORETICAL WEIGHT**  
0,526 Kg/m

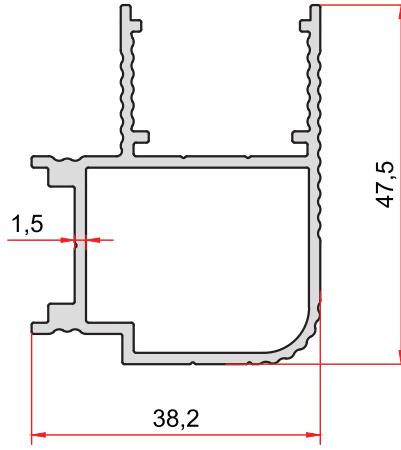

**KOD-CODE** 2676  
**TEORİK AĞIRLIK**  
**THEORETICAL WEIGHT**  
0,705 Kg/m

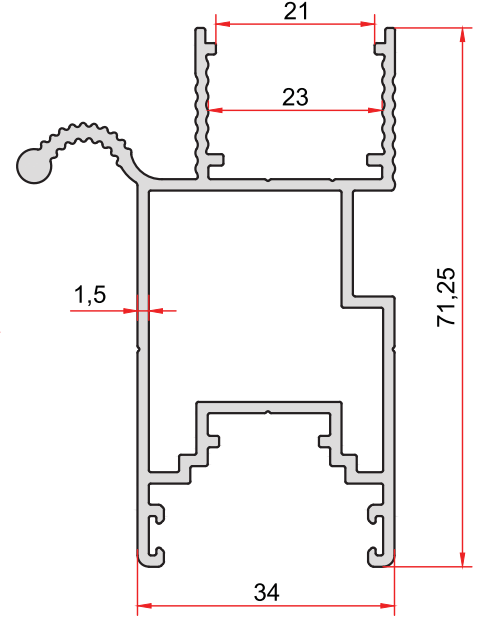

**KOD-CODE** 2675  
**TEORİK AĞIRLIK**  
**THEORETICAL WEIGHT**  
1,124 Kg/m

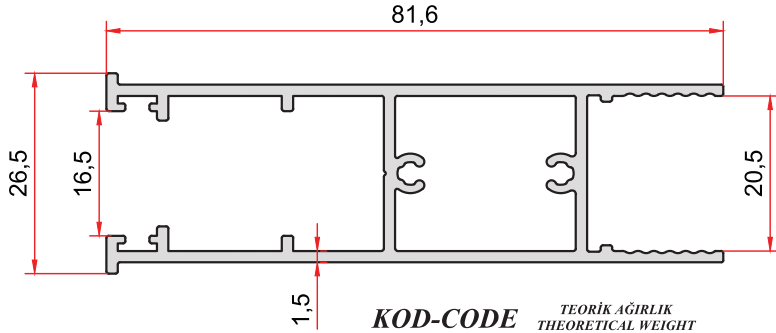

**KOD-CODE** 2674  
**TEORİK AĞIRLIK**  
**THEORETICAL WEIGHT**  
0,958 Kg/m

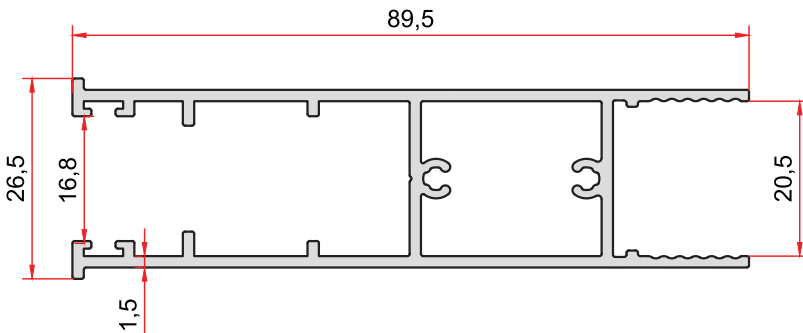

**KOD-CODE** 2673  
**TEORİK AĞIRLIK**  
**THEORETICAL WEIGHT**  
1,040 Kg/m

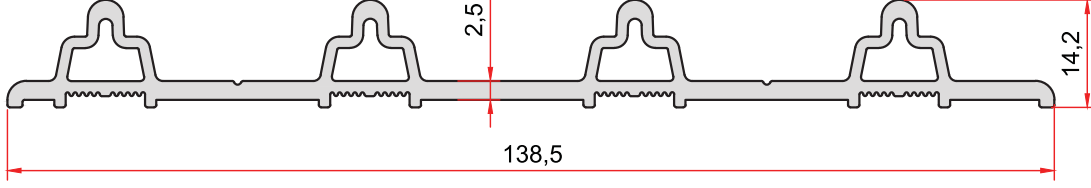

**KOD-CODE**  
**2671**  
TEORİK AĞIRLIK  
THEORETICAL WEIGHT  
**1,344 Kg/m**

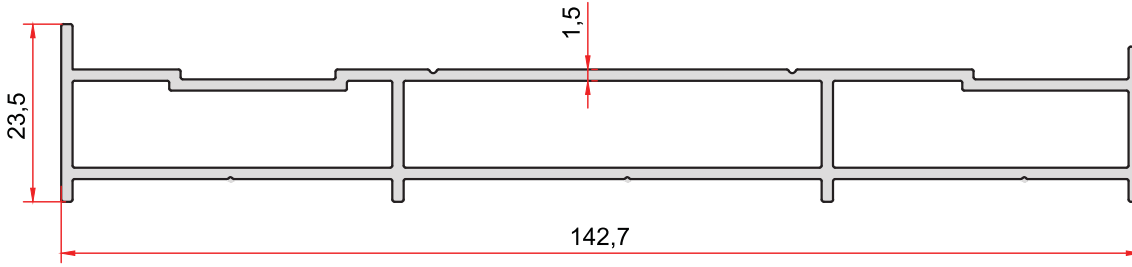

**KOD-CODE**  
**2672**  
TEORİK AĞIRLIK  
THEORETICAL WEIGHT  
**1,439 Kg/m**

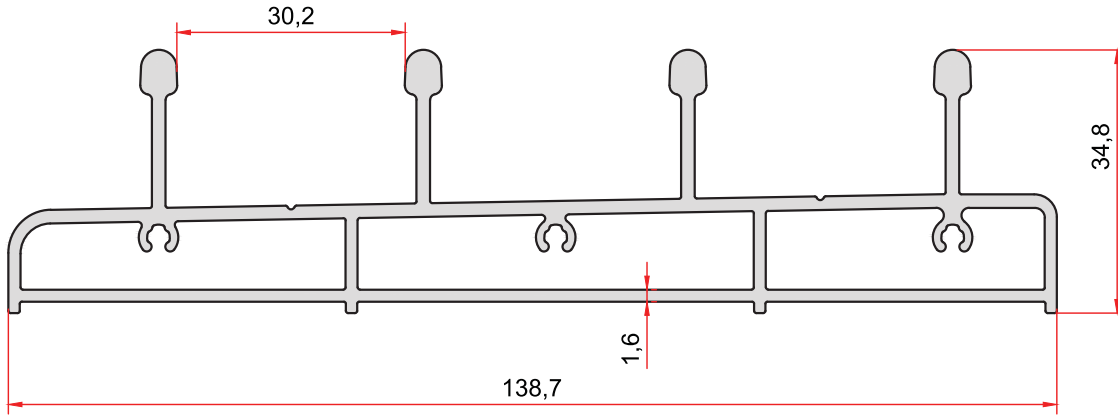

**KOD-CODE**  
**2670**  
TEORİK AĞIRLIK  
THEORETICAL WEIGHT  
**2,107 Kg/m**

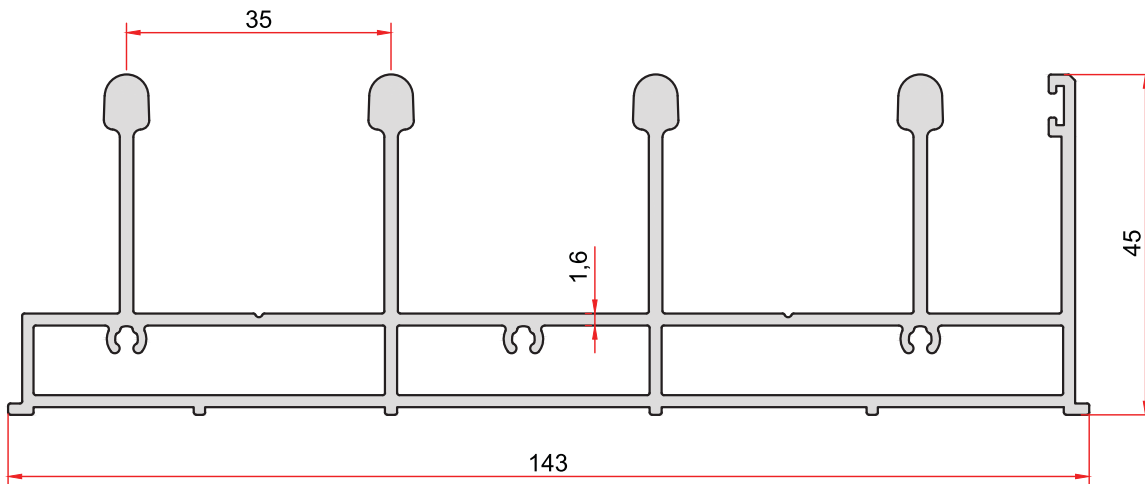

**KOD-CODE**  
**2669**  
TEORİK AĞIRLIK  
THEORETICAL WEIGHT  
**2,538 Kg/m**

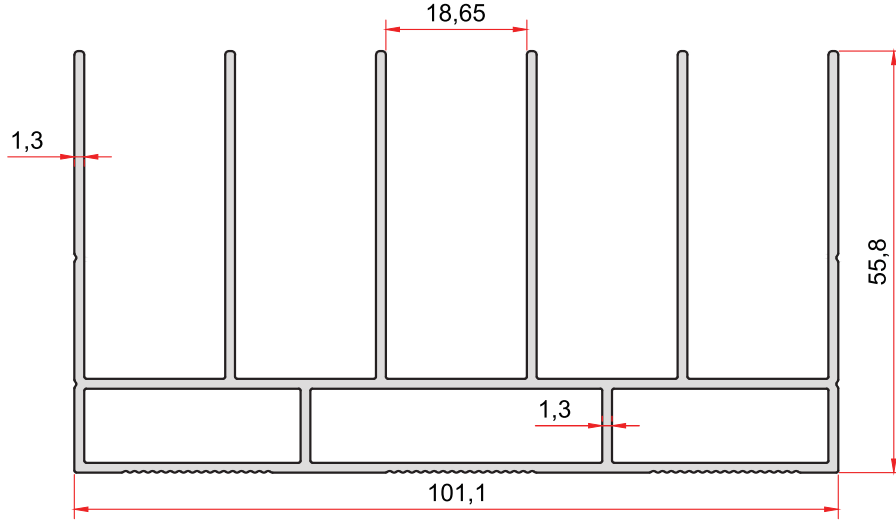

**KOD-CODE** *TEORİK AĞIRLIK*  
*THEORETICAL WEIGHT*  
**2438** **1,741 Kg/m**

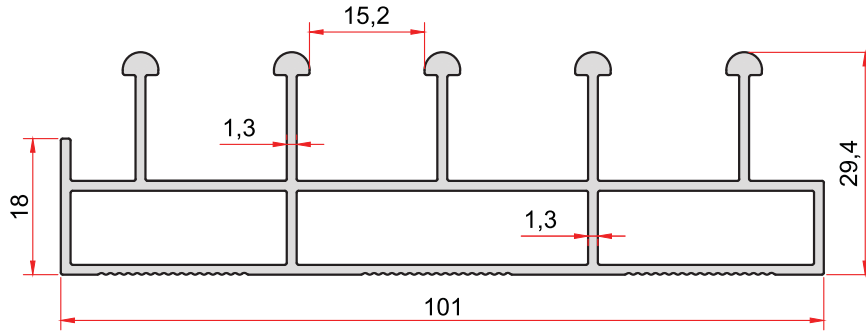

**KOD-CODE** *TEORİK AĞIRLIK*  
*THEORETICAL WEIGHT*  
**2439** **1,253 Kg/m**

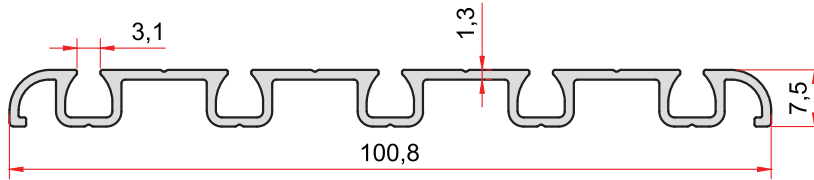

**KOD-CODE** *TEORİK AĞIRLIK*  
*THEORETICAL WEIGHT*  
**2440** **0,629 Kg/m**

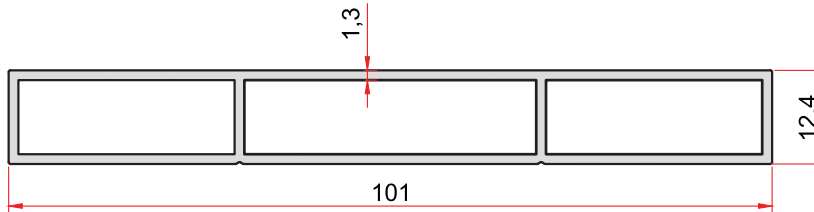

**KOD-CODE** *TEORİK AĞIRLIK*  
*THEORETICAL WEIGHT*  
**2442** **0,845 Kg/m**

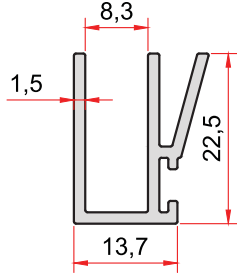

**KOD-CODE** *TEORİK AĞIRLIK*  
*THEORETICAL WEIGHT*  
**2443** **0,300 Kg/m**

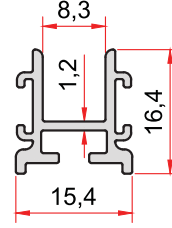

**KOD-CODE** *TEORİK AĞIRLIK*  
*THEORETICAL WEIGHT*  
**2441** **0,205 Kg/m**

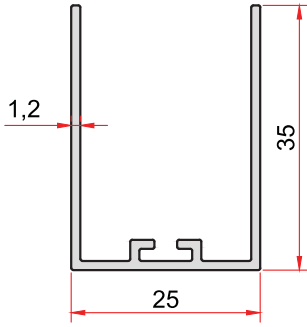

**KOD-CODE** *TEORİK AĞIRLIK*  
*THEORETICAL WEIGHT*  
**2437** **0,332 Kg/m**

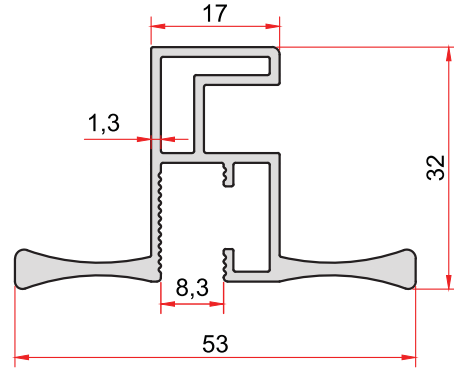

**KOD-CODE** *TEORİK AĞIRLIK*  
*THEORETICAL WEIGHT*  
**2446** **0,653 Kg/m**

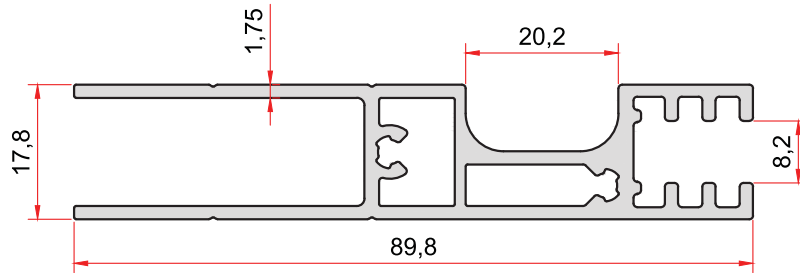

**KOD-CODE** *TEORİK AĞIRLIK*  
*THEORETICAL WEIGHT*  
**2444** **1,226 Kg/m**

# Cam Balkon Profilleri

## Isı Camlı Cam Balkon

**ARFEM**<sup>®</sup>  
ALÜMİNYUM

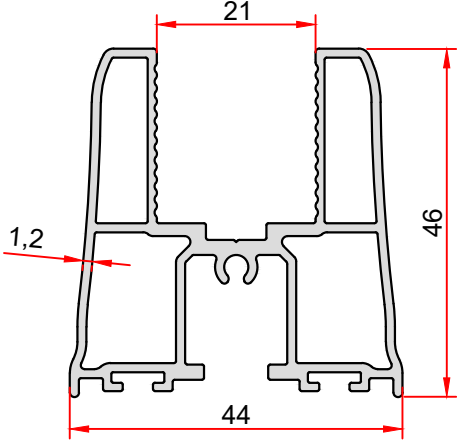

**KOD-CODE** 2655  
**TEORİK AĞIRLIK**  
**THEORETICAL WEIGHT** 0,950 Kg/m

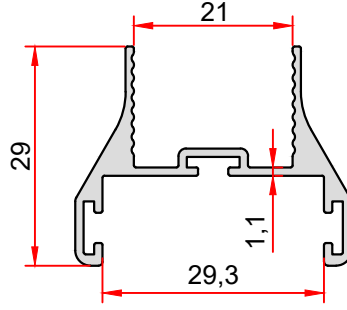

**KOD-CODE** 2656  
**TEORİK AĞIRLIK**  
**THEORETICAL WEIGHT** 0,423 Kg/m

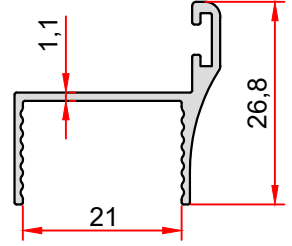

**KOD-CODE** 2657  
**TEORİK AĞIRLIK**  
**THEORETICAL WEIGHT** 0,230 Kg/m

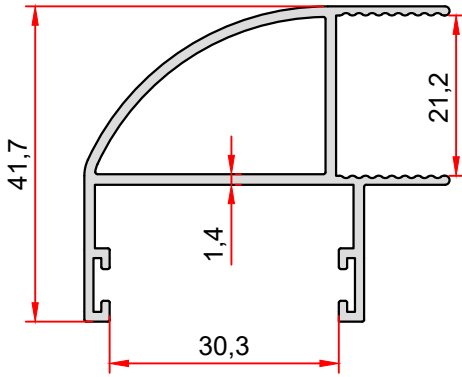

**KOD-CODE** 2668  
**TEORİK AĞIRLIK**  
**THEORETICAL WEIGHT** 0,621 Kg/m

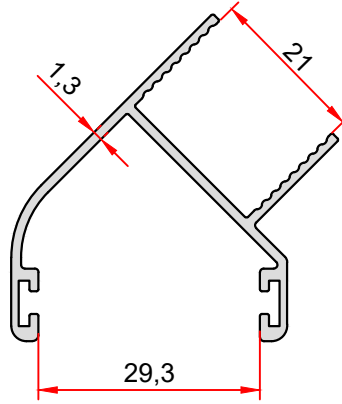

**KOD-CODE** 2661  
**TEORİK AĞIRLIK**  
**THEORETICAL WEIGHT** 0,418 Kg/m

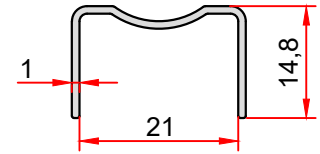

**KOD-CODE** 2658  
**TEORİK AĞIRLIK**  
**THEORETICAL WEIGHT** 0,135 Kg/m

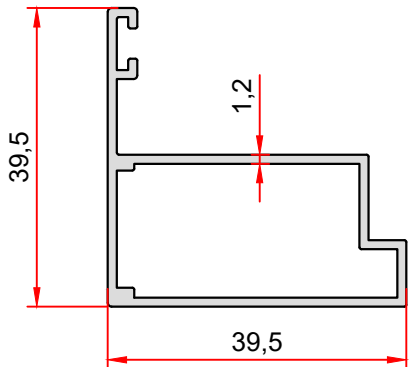

**KOD-CODE** 2660  
**TEORİK AĞIRLIK**  
**THEORETICAL WEIGHT** 0,472 Kg/m



Y.E.S. PREFABRİK  
SAYI 345 82 32

**ARFEM**<sup>®</sup>  
ALÜMİNYUM

**KepenK Profilleri**

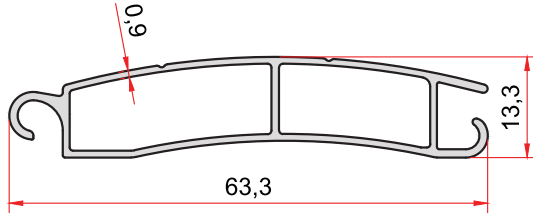

**KOD-CODE** *TEORİK AĞIRLIK*  
*THEORETICAL WEIGHT*  
**2313** **0,402 Kg/m**

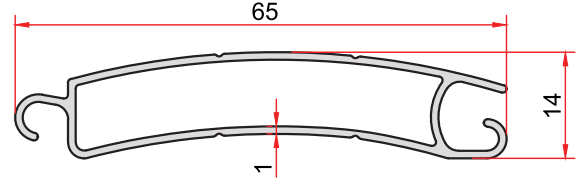

**KOD-CODE** *TEORİK AĞIRLIK*  
*THEORETICAL WEIGHT*  
**2316** **0,410 Kg/m**

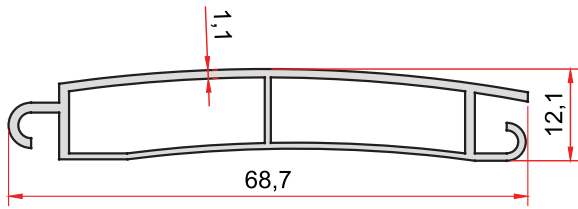

**KOD-CODE** *TEORİK AĞIRLIK*  
*THEORETICAL WEIGHT*  
**2304** **0,454 Kg/m**

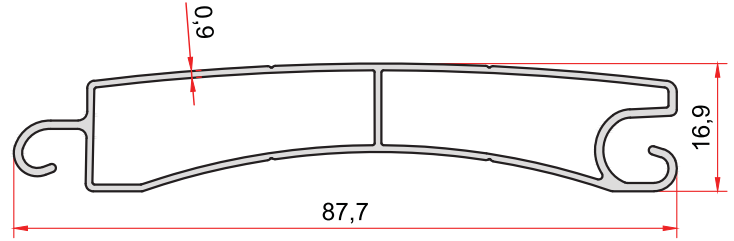

**KOD-CODE** *TEORİK AĞIRLIK*  
*THEORETICAL WEIGHT*  
**2301** **0,572 Kg/m**

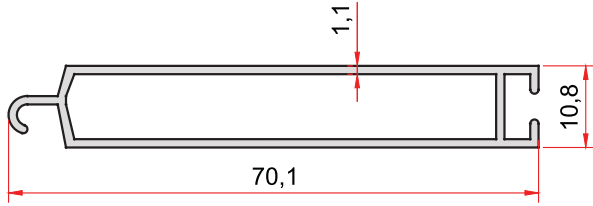

**KOD-CODE** *TEORİK AĞIRLIK*  
*THEORETICAL WEIGHT*  
**2303** **0,470 Kg/m**

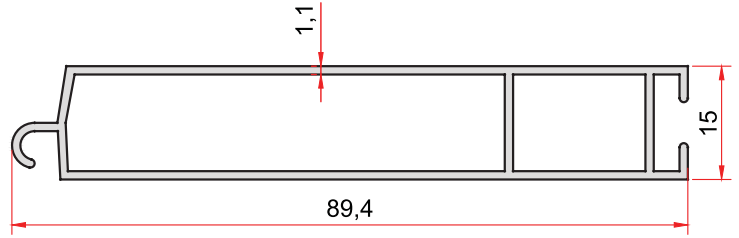

**KOD-CODE** *TEORİK AĞIRLIK*  
*THEORETICAL WEIGHT*  
**2302** **0,659 Kg/m**

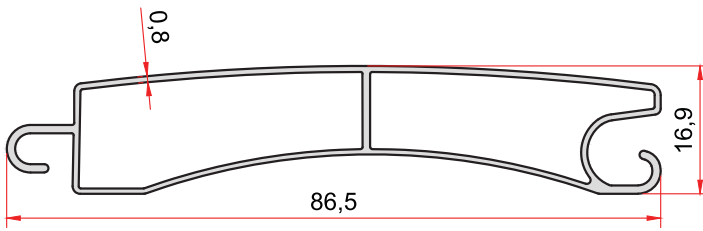

**KOD-CODE** *TEORİK AĞIRLIK*  
*THEORETICAL WEIGHT*  
**2310** **0,486 Kg/m**

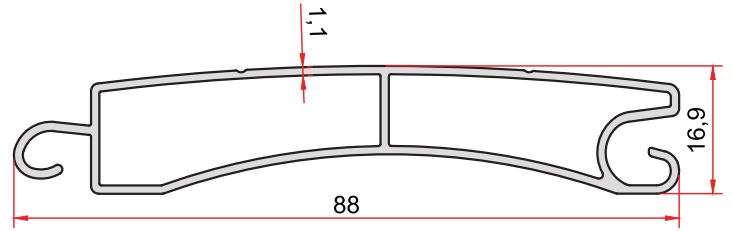

**KOD-CODE** *TEORİK AĞIRLIK*  
*THEORETICAL WEIGHT*  
**2315** **0,667 Kg/m**

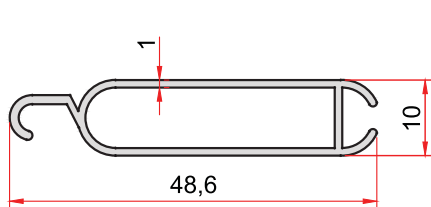

**KOD-CODE** *TEORİK AĞIRLIK*  
*THEORETICAL WEIGHT*  
**2305** **0,297 Kg/m**

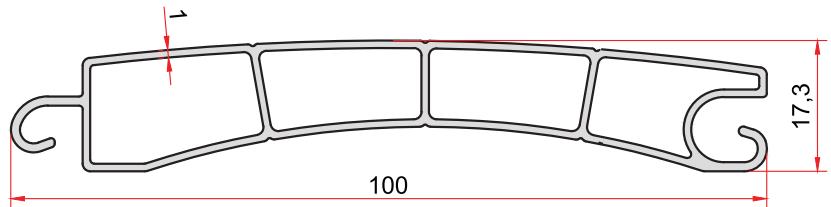

**KOD-CODE** *TEORİK AĞIRLIK*  
*THEORETICAL WEIGHT*  
**2311** **0,748 Kg/m**



# Kepenç Profilleri

**ARFEM**<sup>®</sup>  
ALÜMİNYUM

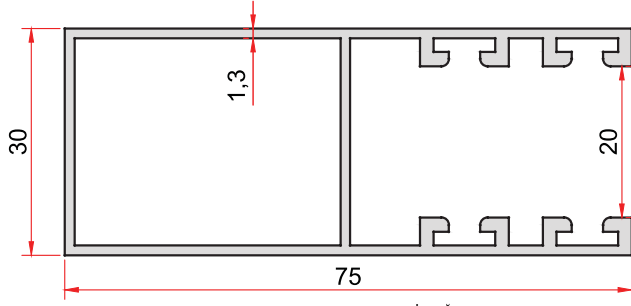

**KOD-CODE** *TEORİK AĞIRLIK*  
*THEORETICAL WEIGHT*  
2306 0,937 Kg/m

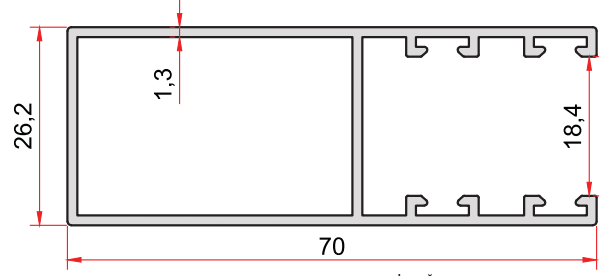

**KOD-CODE** *TEORİK AĞIRLIK*  
*THEORETICAL WEIGHT*  
2314 0,764 Kg/m

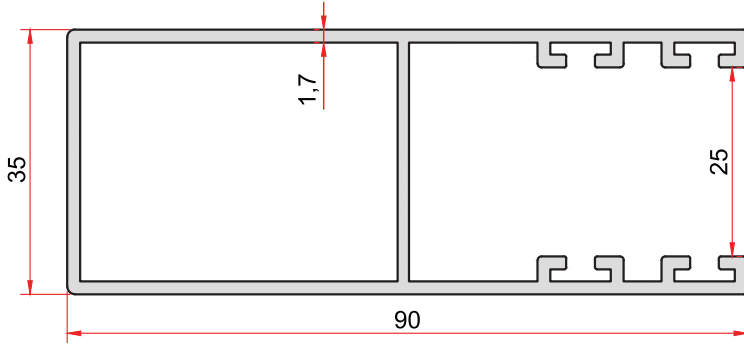

**KOD-CODE** *TEORİK AĞIRLIK*  
*THEORETICAL WEIGHT*  
2307 1,293 Kg/m

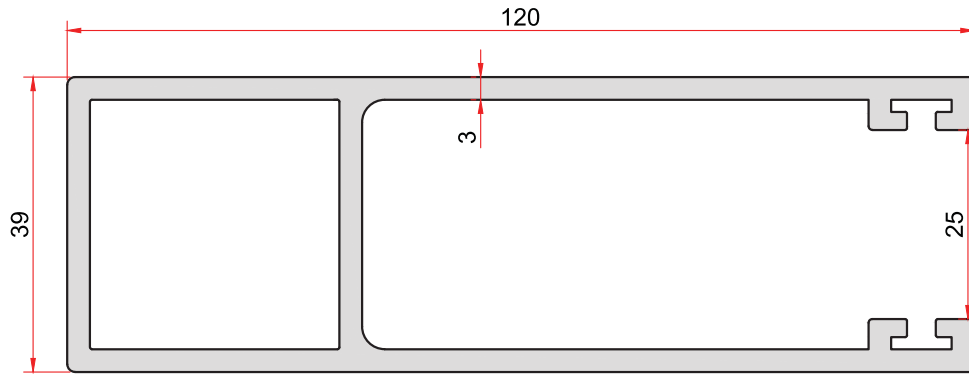

**KOD-CODE** *TEORİK AĞIRLIK*  
*THEORETICAL WEIGHT*  
2312 2,670 Kg/m

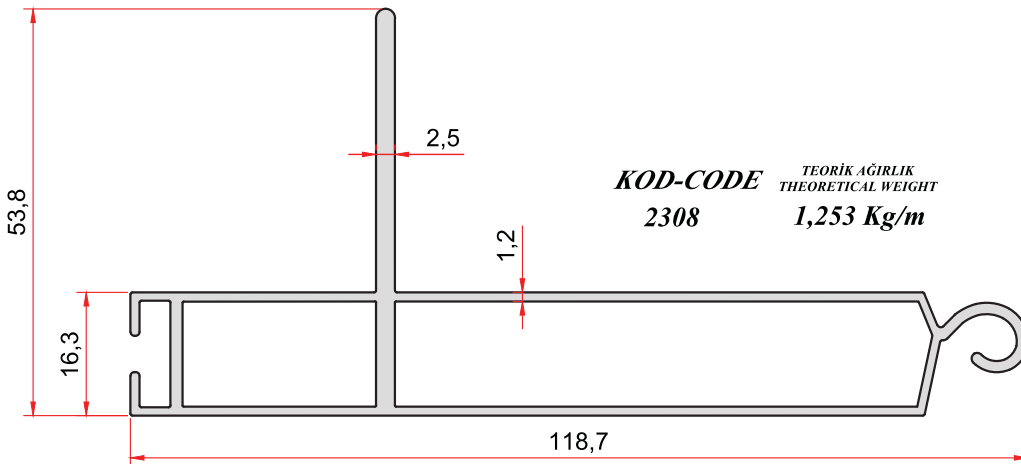

**KOD-CODE** *TEORİK AĞIRLIK*  
*THEORETICAL WEIGHT*  
2308 1,253 Kg/m





**ARFEM**<sup>®</sup>  
ALÜMİNYUM  
Özel Profiller

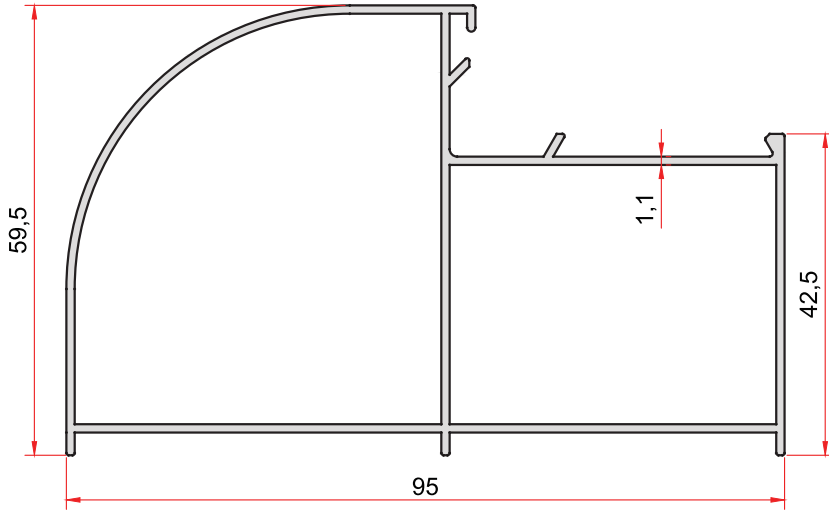

**KOD-CODE** TEORİK AĞIRLIK  
THEORETICAL WEIGHT  
**806** 1,023 Kg/m

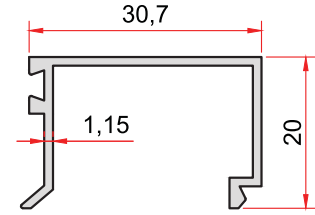

**KOD-CODE** TEORİK AĞIRLIK  
THEORETICAL WEIGHT  
**859** 0,248 Kg/m

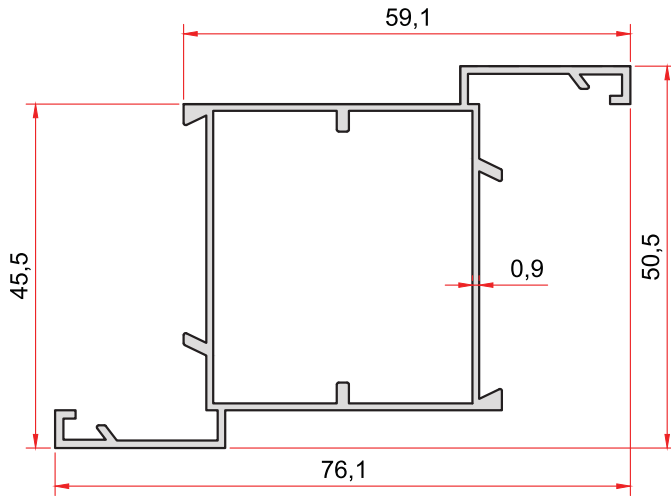

**KOD-CODE** TEORİK AĞIRLIK  
THEORETICAL WEIGHT  
**860** 0,645 Kg/m

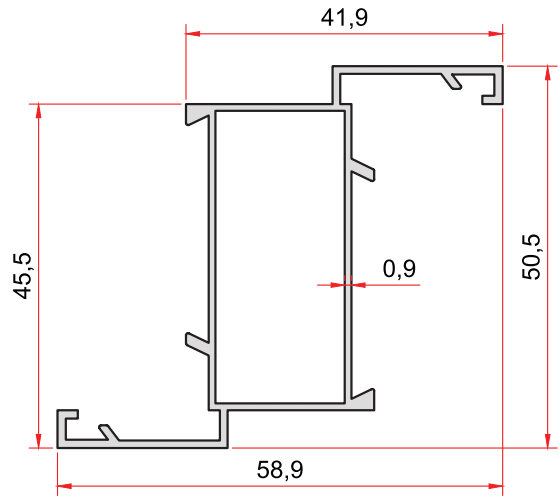

**KOD-CODE** TEORİK AĞIRLIK  
THEORETICAL WEIGHT  
**861** 0,537 Kg/m

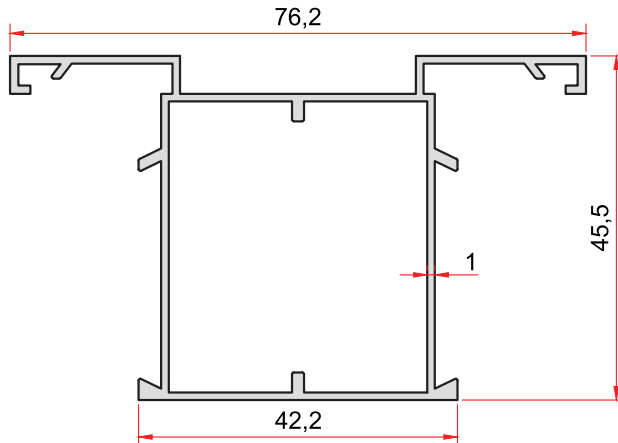

**KOD-CODE** TEORİK AĞIRLIK  
THEORETICAL WEIGHT  
**856** 0,683 Kg/m

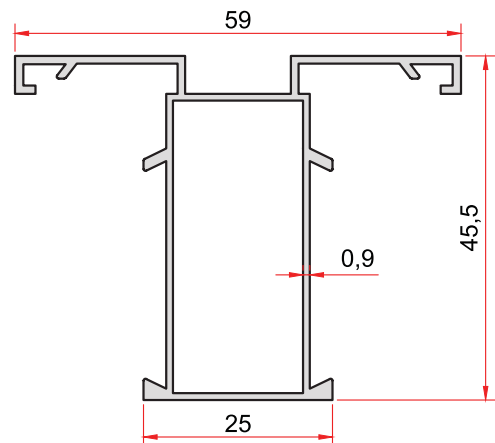

**KOD-CODE** TEORİK AĞIRLIK  
THEORETICAL WEIGHT  
**862** 0,537 Kg/m

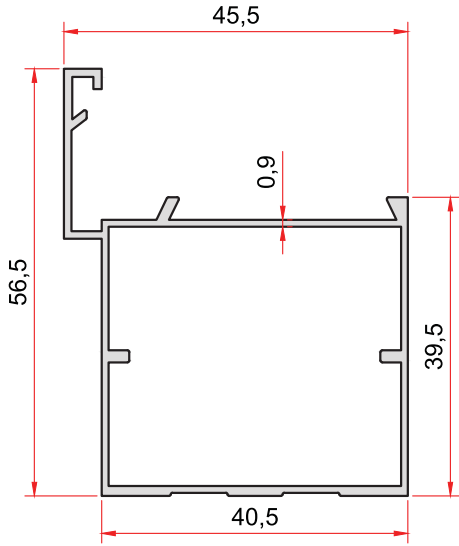

**KOD-CODE** 858  
**TEORİK AĞIRLIK**  
THEORETICAL WEIGHT  
0,543 Kg/m

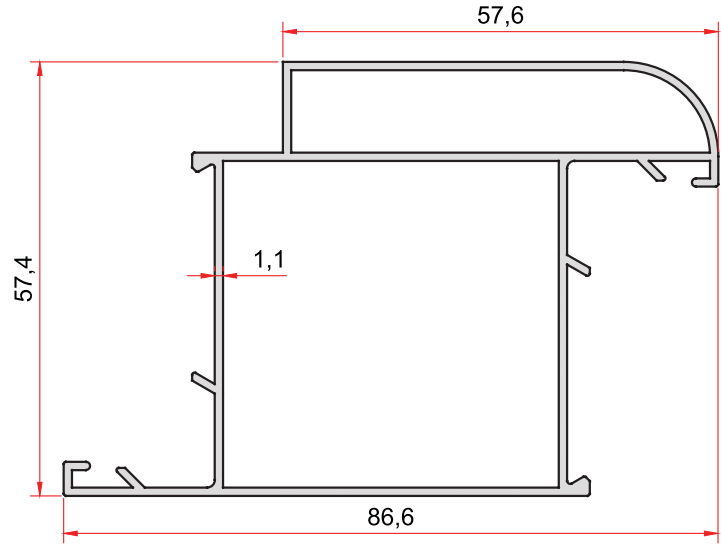

**KOD-CODE** 805  
**TEORİK AĞIRLIK**  
THEORETICAL WEIGHT  
0,983 Kg/m

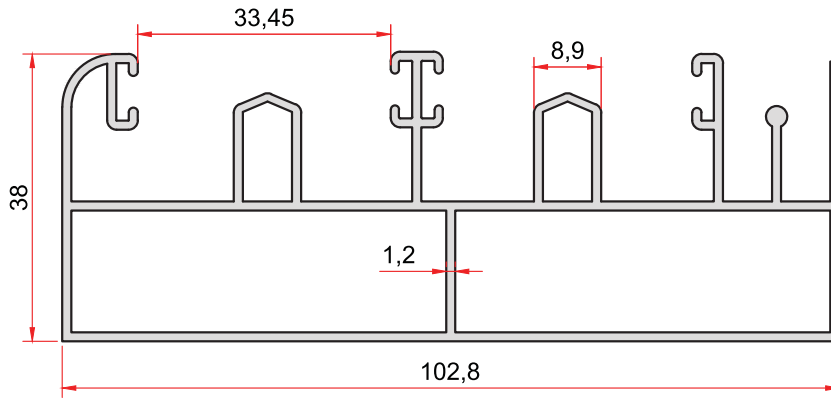

**KOD-CODE** 873  
**TEORİK AĞIRLIK**  
THEORETICAL WEIGHT  
1,471 Kg/m

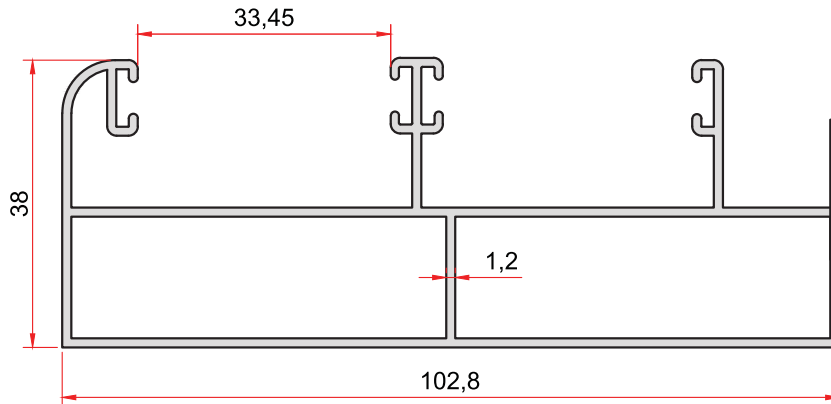

**KOD-CODE** 872  
**TEORİK AĞIRLIK**  
THEORETICAL WEIGHT  
1,215 Kg/m

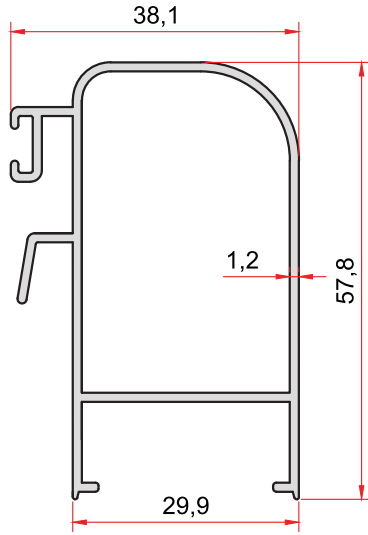

**KOD-CODE** *TEORİK AĞIRLIK*  
*THEORETICAL WEIGHT*  
874 0,656 Kg/m

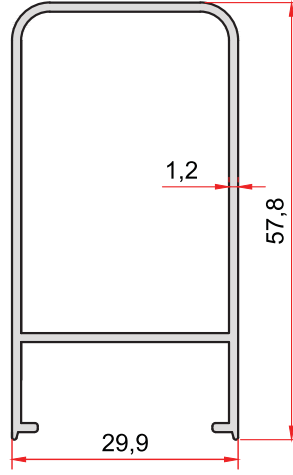

**KOD-CODE** *TEORİK AĞIRLIK*  
*THEORETICAL WEIGHT*  
875 0,551 Kg/m

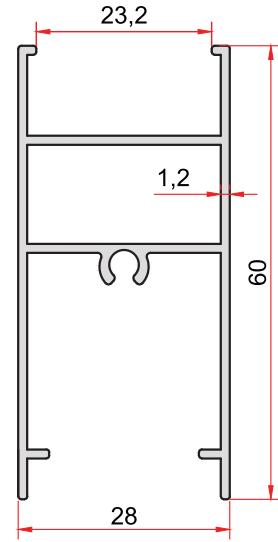

**KOD-CODE** *TEORİK AĞIRLIK*  
*THEORETICAL WEIGHT*  
876 0,610 Kg/m

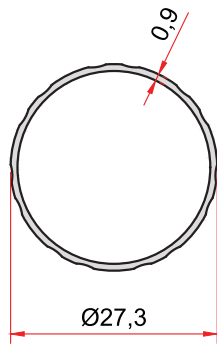

**KOD-CODE** *TEORİK AĞIRLIK*  
*THEORETICAL WEIGHT*  
4022 0,189 Kg/m

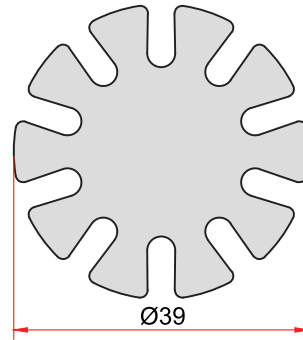

**KOD-CODE** *TEORİK AĞIRLIK*  
*THEORETICAL WEIGHT*  
5094 2,438 Kg/m

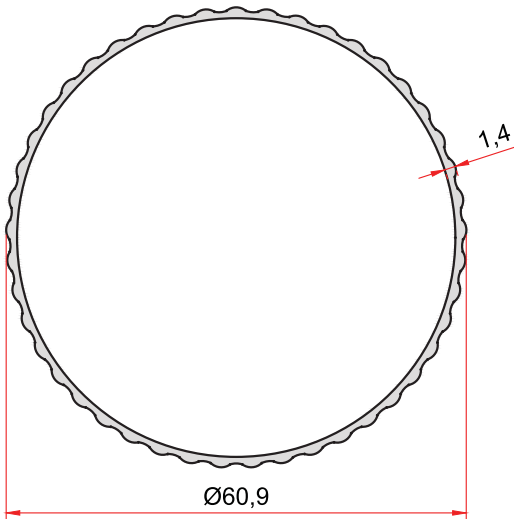

**KOD-CODE** *TEORİK AĞIRLIK*  
*THEORETICAL WEIGHT*  
4014 0,583 Kg/m

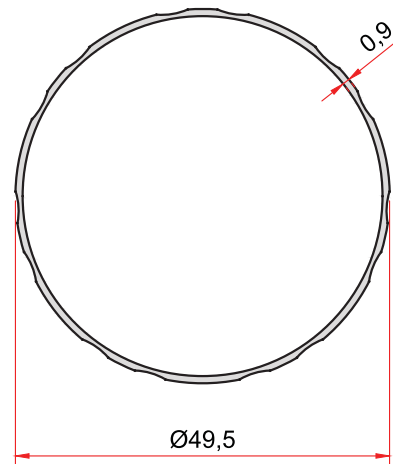

**KOD-CODE** *TEORİK AĞIRLIK*  
*THEORETICAL WEIGHT*  
4021 0,356 Kg/m

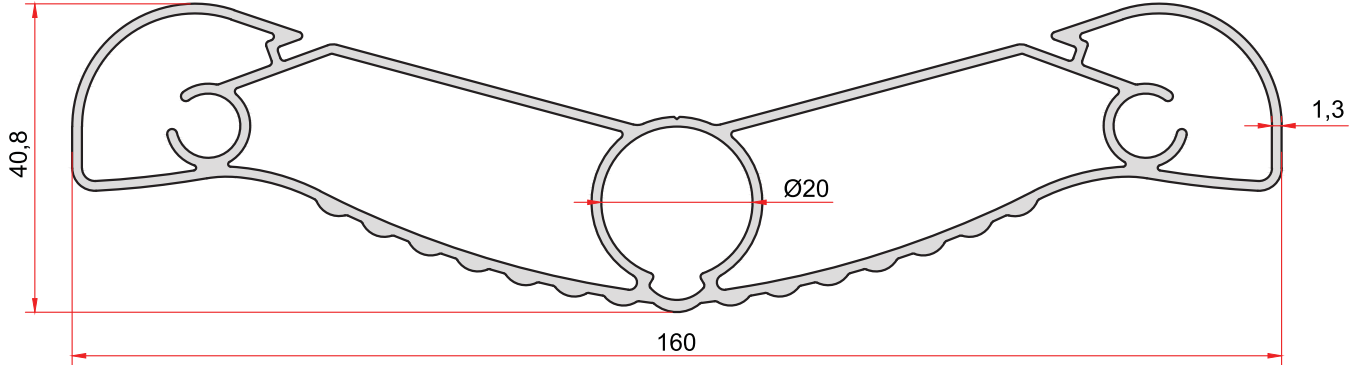

**KOD-CODE** *TEORİK AĞIRLIK*  
**4013** *THEORETICAL WEIGHT*  
**1,852 Kg/m**

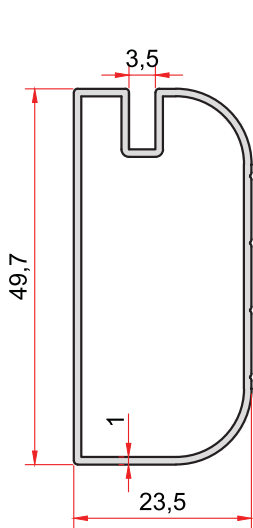

**KOD-CODE** *TEORİK AĞIRLIK*  
**877** *THEORETICAL WEIGHT*  
**0,402 Kg/m**

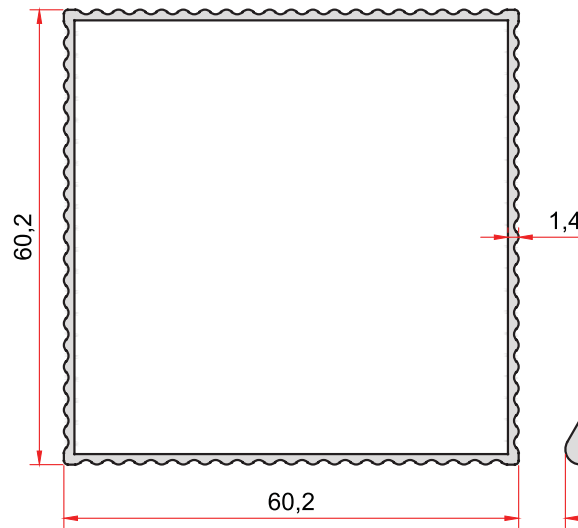

**KOD-CODE** *TEORİK AĞIRLIK*  
**4015** *THEORETICAL WEIGHT*  
**0,702 Kg/m**

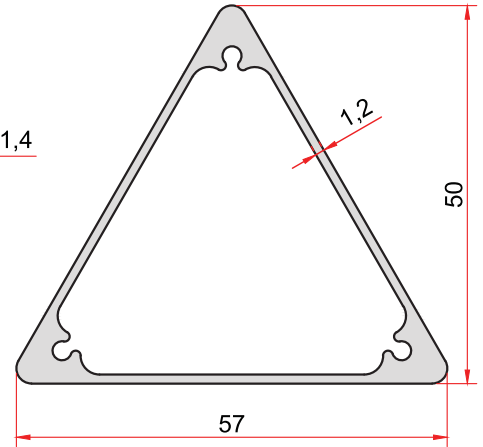

**KOD-CODE** *TEORİK AĞIRLIK*  
**4018** *THEORETICAL WEIGHT*  
**0,788 Kg/m**

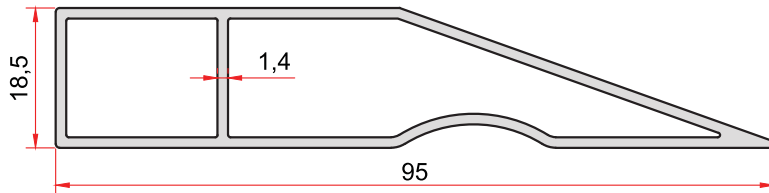

**KOD-CODE** *TEORİK AĞIRLIK*  
**4000** *THEORETICAL WEIGHT*  
**0,837 Kg/m**

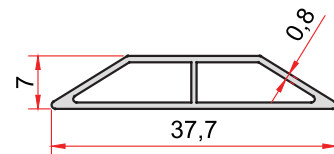

**KOD-CODE** *TEORİK AĞIRLIK*  
**4002** *THEORETICAL WEIGHT*  
**0,189 Kg/m**

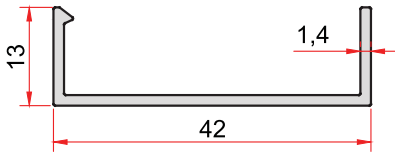

**KOD-CODE**      **TEORİK AĞIRLIK**  
**4003**            **THEORETICAL WEIGHT**  
0,248 Kg/m

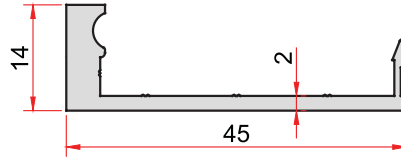

**KOD-CODE**      **TEORİK AĞIRLIK**  
**4011**            **THEORETICAL WEIGHT**  
0,402 Kg/m

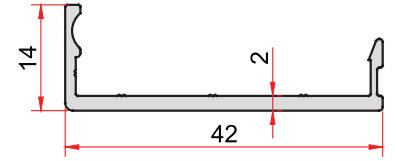

**KOD-CODE**      **TEORİK AĞIRLIK**  
**4012**            **THEORETICAL WEIGHT**  
0,292 Kg/m

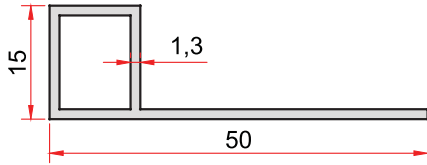

**KOD-CODE**      **TEORİK AĞIRLIK**  
**4020**            **THEORETICAL WEIGHT**  
0,302 Kg/m

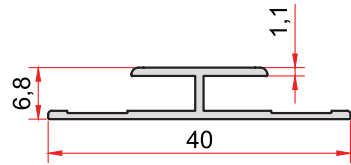

**KOD-CODE**      **TEORİK AĞIRLIK**  
**1061**            **THEORETICAL WEIGHT**  
0,173 Kg/m

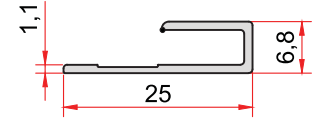

**KOD-CODE**      **TEORİK AĞIRLIK**  
**1062**            **THEORETICAL WEIGHT**  
0,116 Kg/m

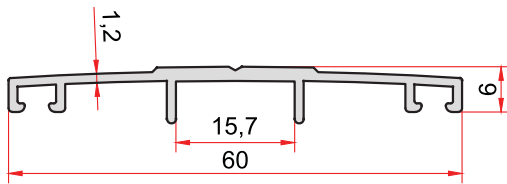

**KOD-CODE**      **TEORİK AĞIRLIK**  
**1063**            **THEORETICAL WEIGHT**  
0,321 Kg/m

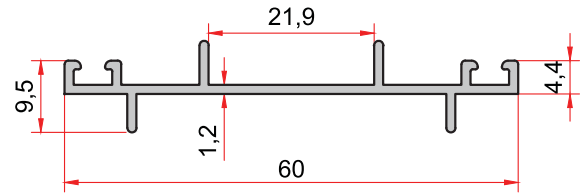

**KOD-CODE**      **TEORİK AĞIRLIK**  
**1064**            **THEORETICAL WEIGHT**  
0,313 Kg/m

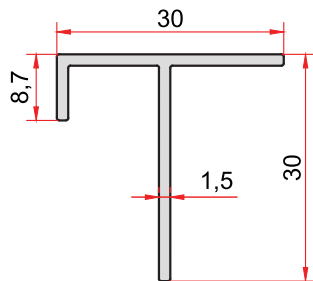

**KOD-CODE**      **TEORİK AĞIRLIK**  
**1059**            **THEORETICAL WEIGHT**  
0,265 Kg/m

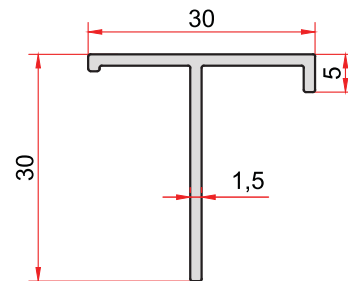

**KOD-CODE**      **TEORİK AĞIRLIK**  
**1060**            **THEORETICAL WEIGHT**  
0,254 Kg/m



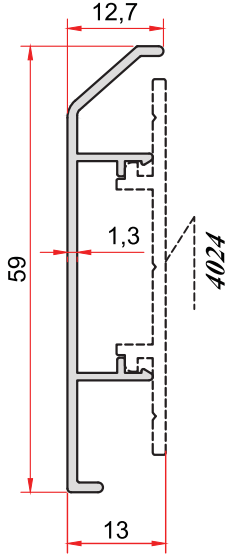

**KOD-CODE** *TEORİK AĞIRLIK*  
**4025** *THEORETICAL WEIGHT*  
**0,305 Kg/m**

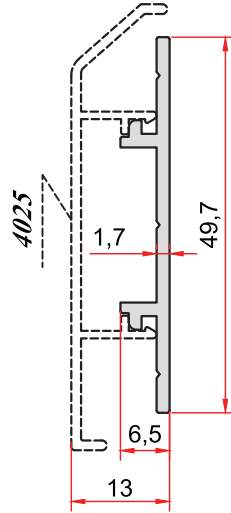

**KOD-CODE** *TEORİK AĞIRLIK*  
**4024** *THEORETICAL WEIGHT*  
**0,286 Kg/m**

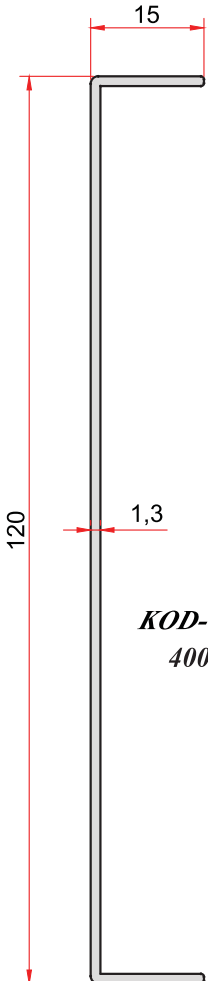
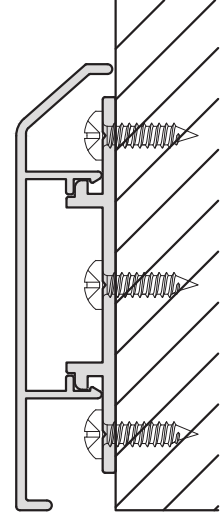

**KOD-CODE** *TEORİK AĞIRLIK*  
**4004** *THEORETICAL WEIGHT*  
**0,516 Kg/m**

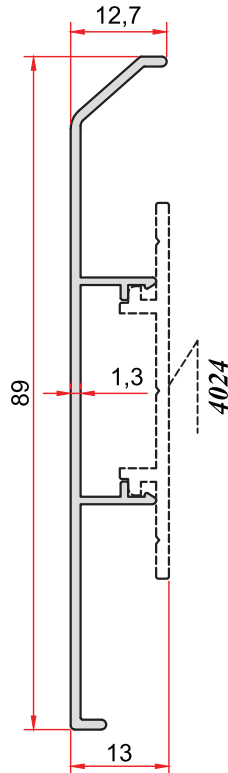

**KOD-CODE** *TEORİK AĞIRLIK*  
**4026** *THEORETICAL WEIGHT*  
**0,410 Kg/m**

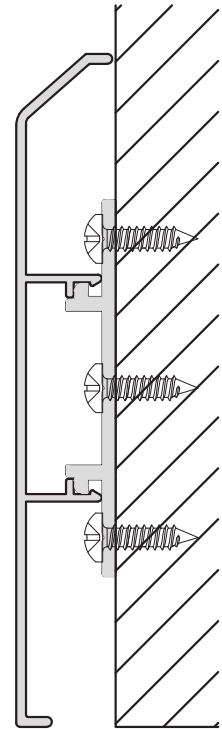

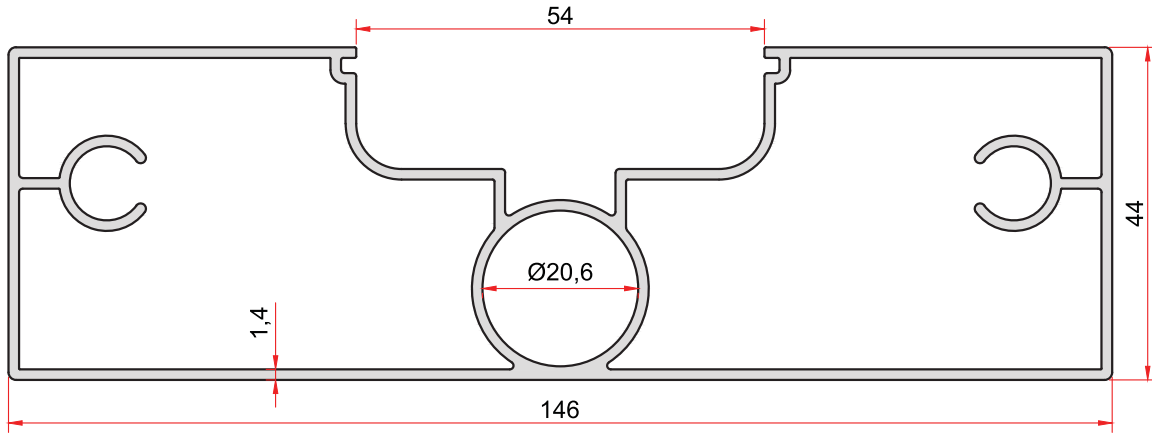

**KOD-CODE** *TEORİK AĞIRLIK*  
*THEORETICAL WEIGHT*  
4027 2,020 Kg/m

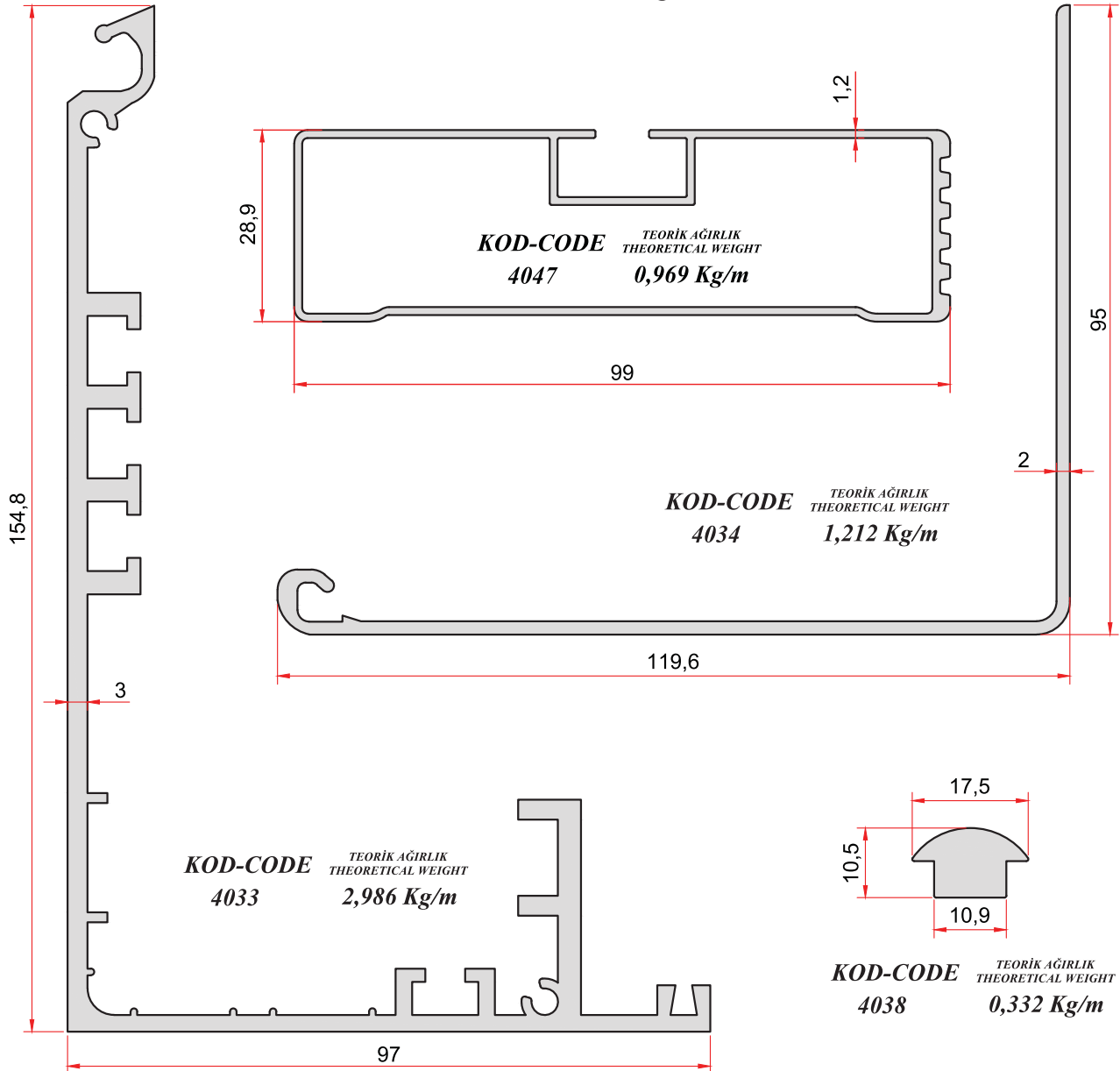

**KOD-CODE** *TEORİK AĞIRLIK*  
*THEORETICAL WEIGHT*  
4033 2,986 Kg/m

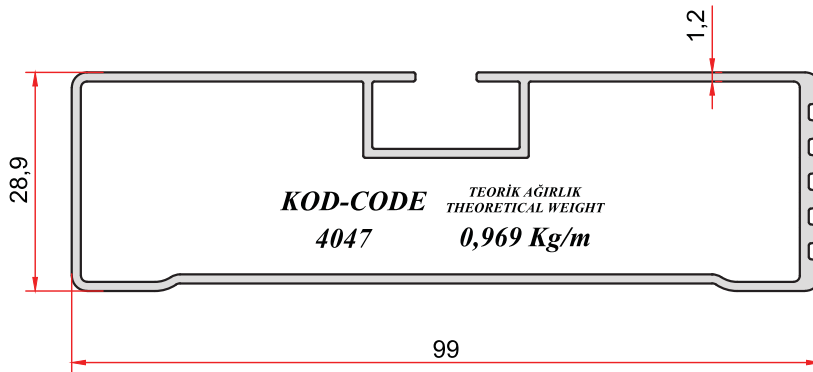

**KOD-CODE** *TEORİK AĞIRLIK*  
*THEORETICAL WEIGHT*  
4047 0,969 Kg/m

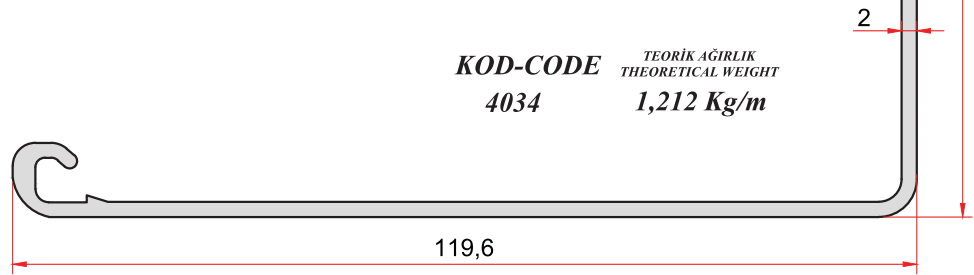

**KOD-CODE** *TEORİK AĞIRLIK*  
*THEORETICAL WEIGHT*  
4034 1,212 Kg/m

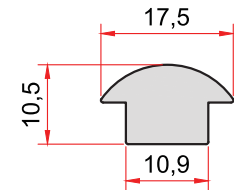

**KOD-CODE** *TEORİK AĞIRLIK*  
*THEORETICAL WEIGHT*  
4038 0,332 Kg/m

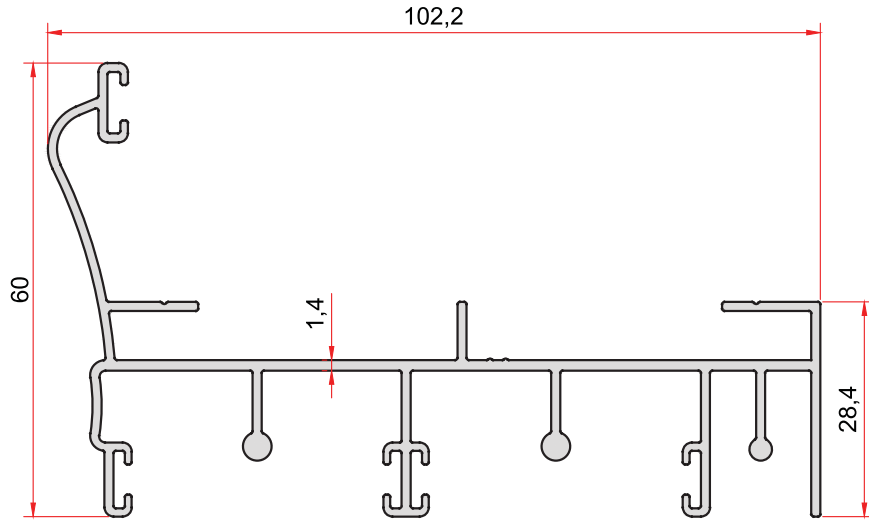

**KOD-CODE** TEORİK AĞIRLIK  
766 THEORETICAL WEIGHT  
1,172 Kg/m

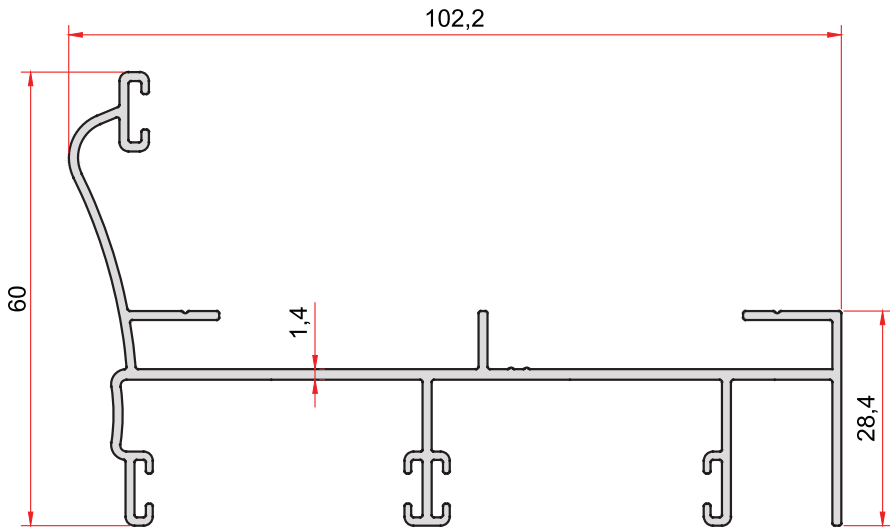

**KOD-CODE** TEORİK AĞIRLIK  
767 THEORETICAL WEIGHT  
1,010 Kg/m

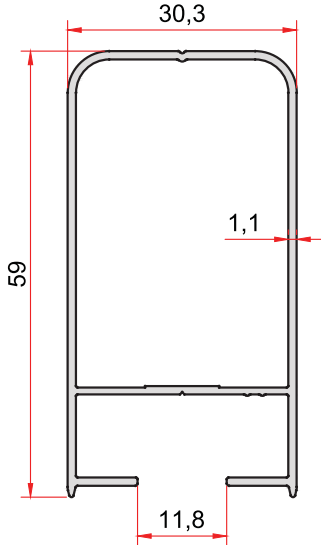

**KOD-CODE** 769 **TEORİK AĞIRLIK** 0,543 Kg/m  
**THEORETICAL WEIGHT**

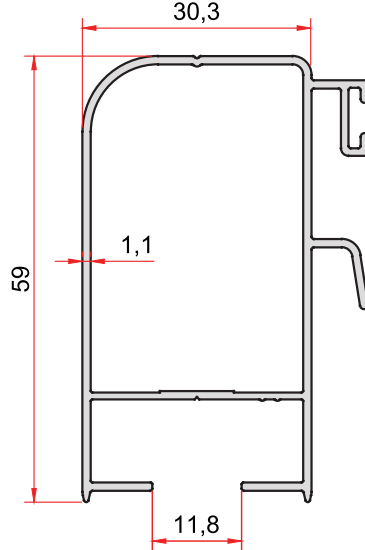

**KOD-CODE** 770 **TEORİK AĞIRLIK** 0,643 Kg/m  
**THEORETICAL WEIGHT**

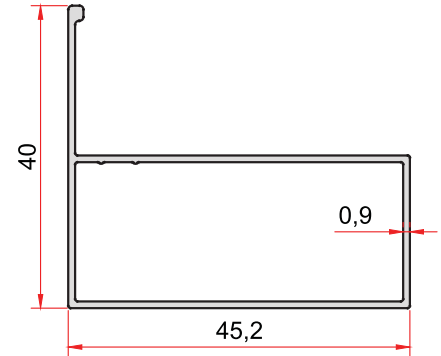

**KOD-CODE** 771 **TEORİK AĞIRLIK** 0,364 Kg/m  
**THEORETICAL WEIGHT**

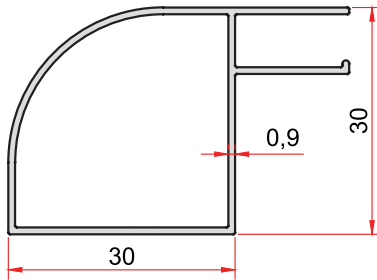

**KOD-CODE** 772 **TEORİK AĞIRLIK** 0,337 Kg/m  
**THEORETICAL WEIGHT**

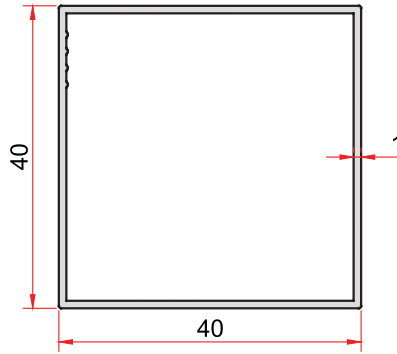

**KOD-CODE** 773 **TEORİK AĞIRLIK** 0,421 Kg/m  
**THEORETICAL WEIGHT**

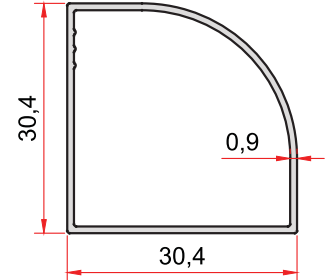

**KOD-CODE** 774 **TEORİK AĞIRLIK** 0,267 Kg/m  
**THEORETICAL WEIGHT**

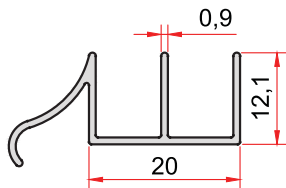

**KOD-CODE** 777 **TEORİK AĞIRLIK** 0,176 Kg/m  
**THEORETICAL WEIGHT**

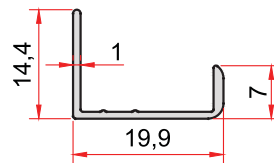

**KOD-CODE** 778 **TEORİK AĞIRLIK** 0,103 Kg/m  
**THEORETICAL WEIGHT**

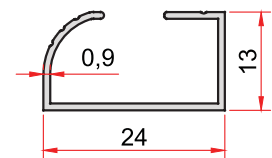

**KOD-CODE** 779 **TEORİK AĞIRLIK** 0,143 Kg/m  
**THEORETICAL WEIGHT**

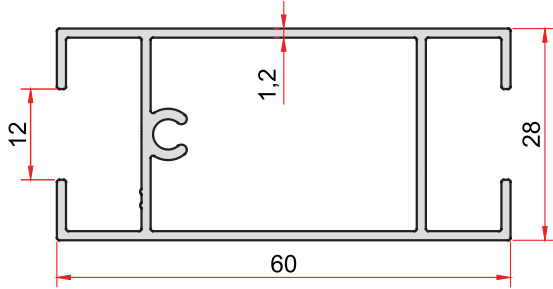

**KOD-CODE** *TEORİK AĞIRLIK*  
*THEORETICAL WEIGHT*  
**780** **0,683 Kg/m**

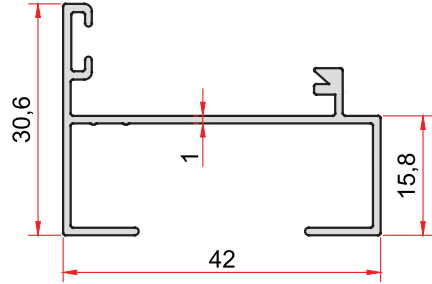

**KOD-CODE** *TEORİK AĞIRLIK*  
*THEORETICAL WEIGHT*  
**781** **0,348 Kg/m**

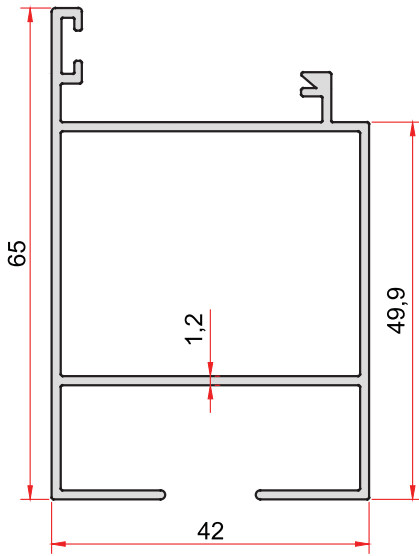

**KOD-CODE** *TEORİK AĞIRLIK*  
*THEORETICAL WEIGHT*  
**782** **0,788 Kg/m**

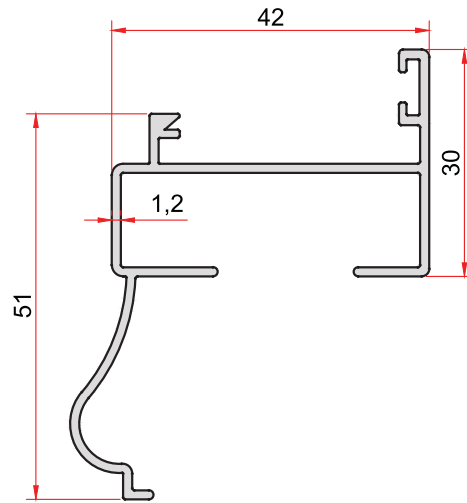

**KOD-CODE** *TEORİK AĞIRLIK*  
*THEORETICAL WEIGHT*  
**783** **0,535 Kg/m**

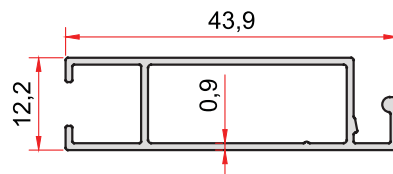

**KOD-CODE** *TEORİK AĞIRLIK*  
*THEORETICAL WEIGHT*  
**768** **0,283 Kg/m**

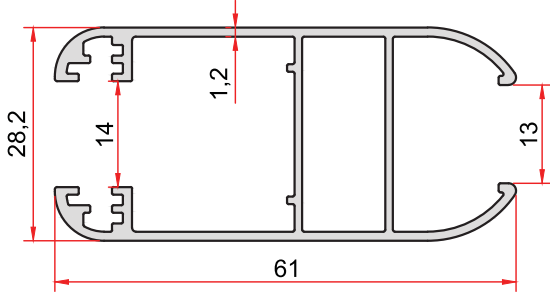

**KOD-CODE** *TEORİK AĞIRLIK*  
*THEORETICAL WEIGHT*  
**784** **0,685 Kg/m**

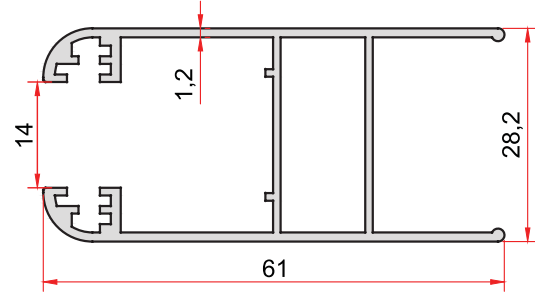

**KOD-CODE** *TEORİK AĞIRLIK*  
*THEORETICAL WEIGHT*  
**786** **0,667 Kg/m**

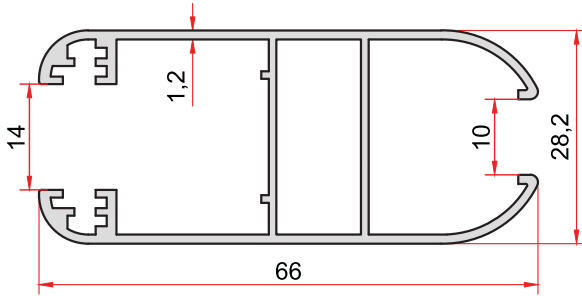

**KOD-CODE** *TEORİK AĞIRLIK*  
*THEORETICAL WEIGHT*  
**785** **0,726 Kg/m**

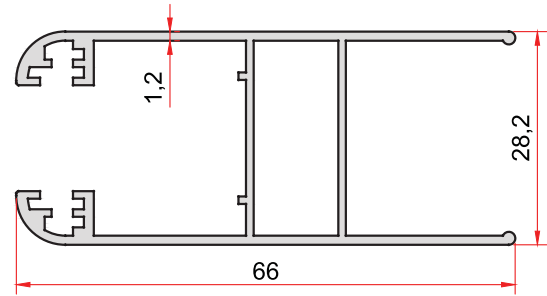

**KOD-CODE** *TEORİK AĞIRLIK*  
*THEORETICAL WEIGHT*  
**851** **0,699 Kg/m**

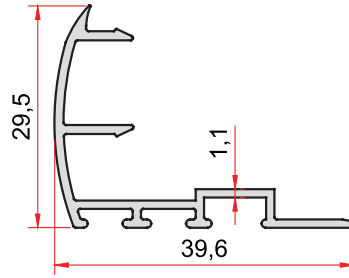

**KOD-CODE** *TEORİK AĞIRLIK*  
*THEORETICAL WEIGHT*  
**787** **0,305 Kg/m**

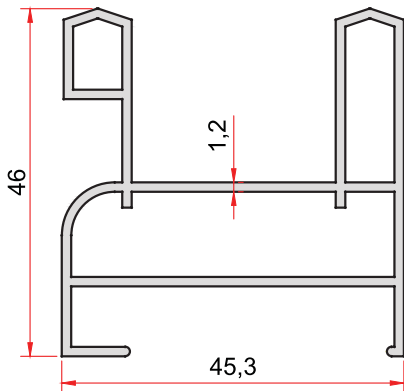

**KOD-CODE** *TEORİK AĞIRLIK*  
*THEORETICAL WEIGHT*  
**788** **0,802 Kg/m**

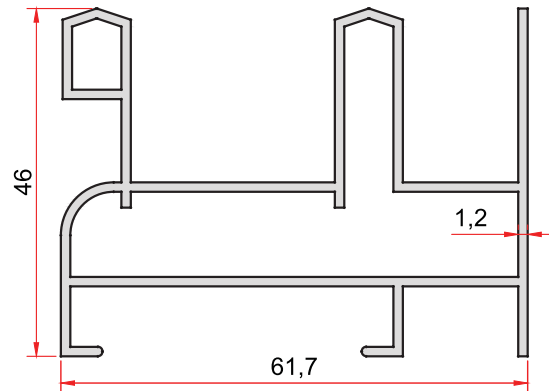

**KOD-CODE** *TEORİK AĞIRLIK*  
*THEORETICAL WEIGHT*  
**803** **0,999 Kg/m**

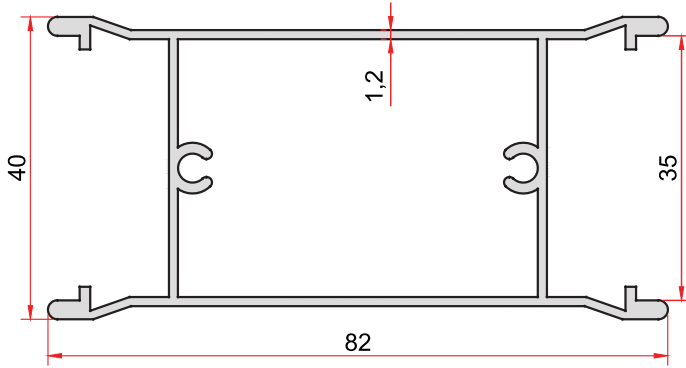
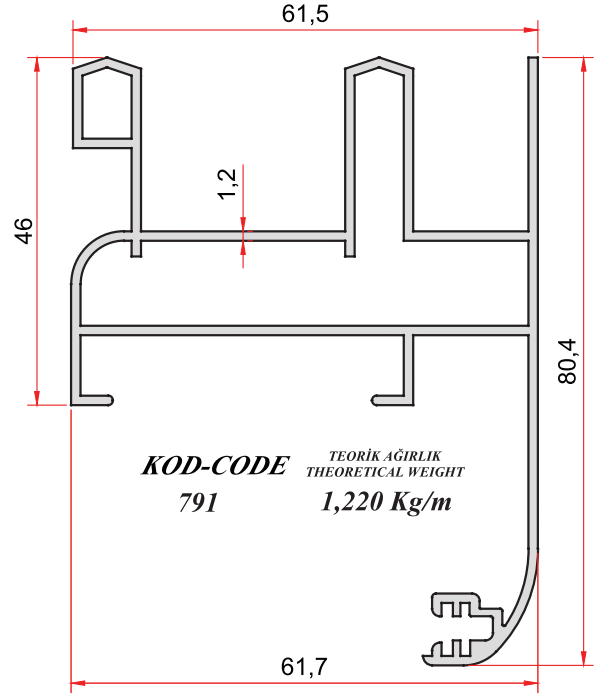
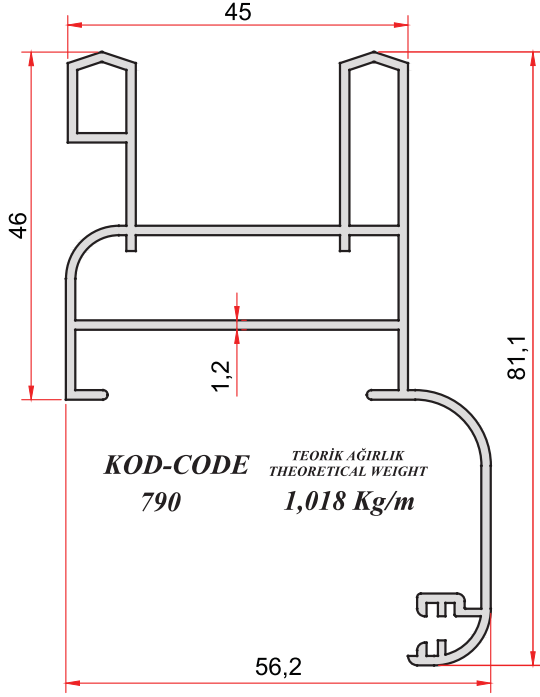

**KOD-CODE** 793 **TEORİK AĞIRLIK** 0,929 Kg/m  
**THEORETICAL WEIGHT**

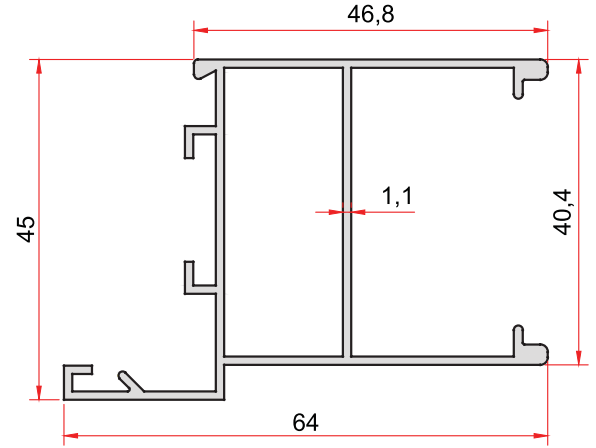

**KOD-CODE** 794 **TEORİK AĞIRLIK** 0,700 Kg/m  
**THEORETICAL WEIGHT**

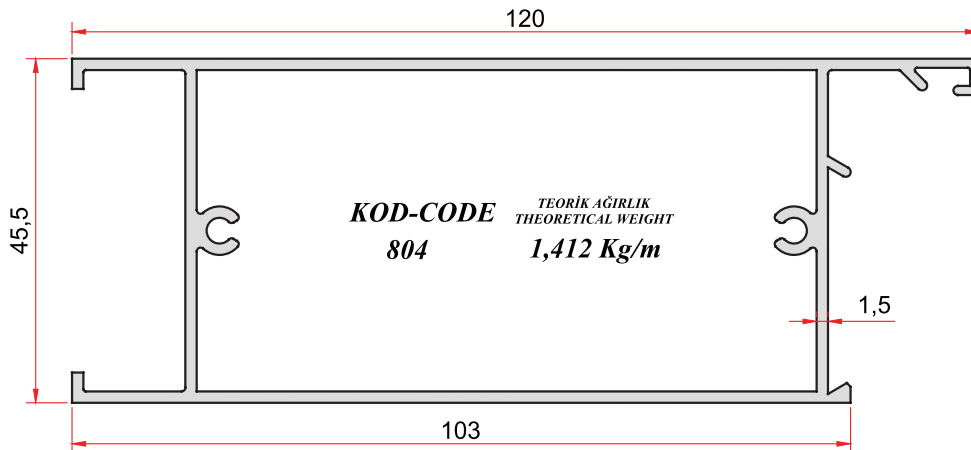

**KOD-CODE** 804 **TEORİK AĞIRLIK** 1,412 Kg/m  
**THEORETICAL WEIGHT**

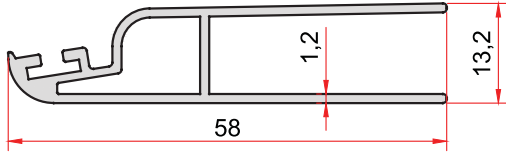

**KOD-CODE** *TEORİK AĞIRLIK*  
*THEORETICAL WEIGHT*  
**798** **0,465 Kg/m**

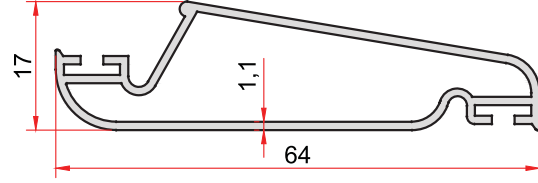

**KOD-CODE** *TEORİK AĞIRLIK*  
*THEORETICAL WEIGHT*  
**797** **0,486 Kg/m**

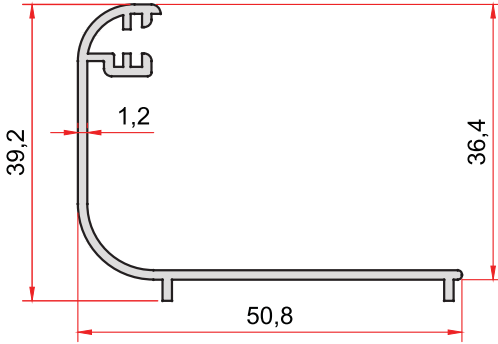

**KOD-CODE** *TEORİK AĞIRLIK*  
*THEORETICAL WEIGHT*  
**800** **0,370 Kg/m**

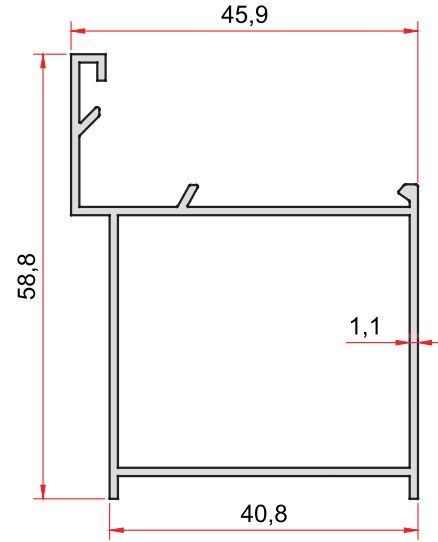

**KOD-CODE** *TEORİK AĞIRLIK*  
*THEORETICAL WEIGHT*  
**799** **0,586 Kg/m**

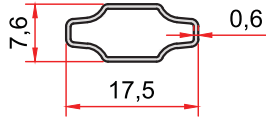

**KOD-CODE** *TEORİK AĞIRLIK*  
*THEORETICAL WEIGHT*  
**792** **0,068 Kg/m**

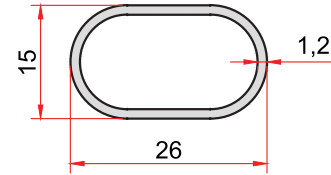

**KOD-CODE** *TEORİK AĞIRLIK*  
*THEORETICAL WEIGHT*  
**802** **0,219 Kg/m**

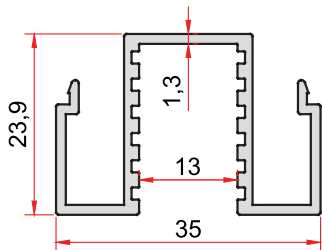

**KOD-CODE** *TEORİK AĞIRLIK*  
*THEORETICAL WEIGHT*  
**796** **0,440 Kg/m**

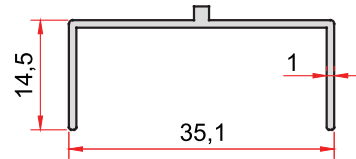

**KOD-CODE** *TEORİK AĞIRLIK*  
*THEORETICAL WEIGHT*  
**795** **0,178 Kg/m**



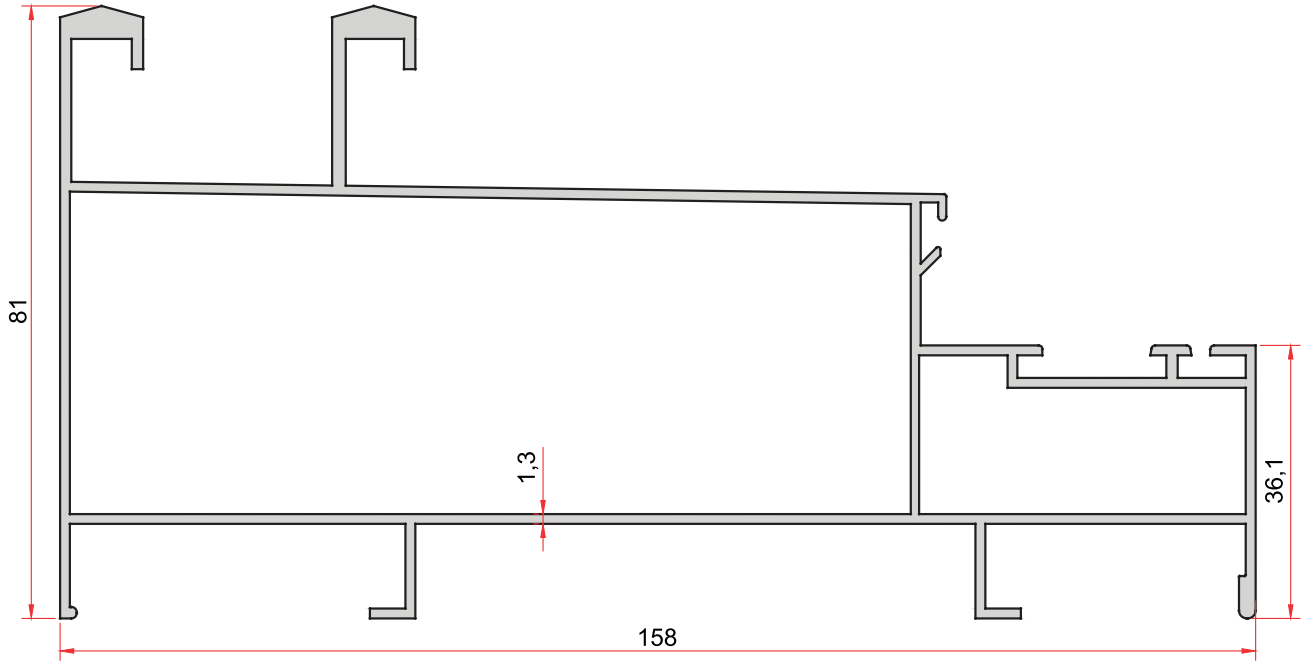

**KOD-CODE**    *TEORİK AĞIRLIK*  
789            *THEORETICAL WEIGHT*  
2,211 Kg/m

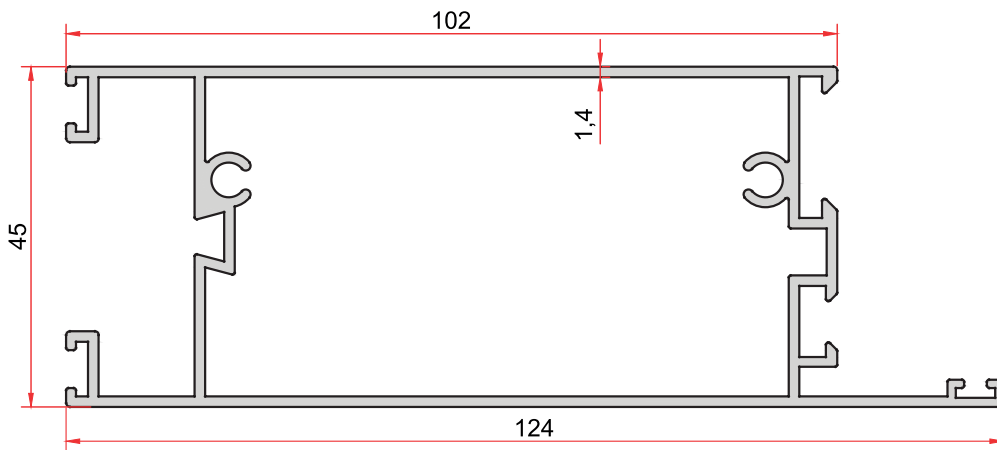

**KOD-CODE**    *TEORİK AĞIRLIK*  
801            *THEORETICAL WEIGHT*  
1,515 Kg/m





**ARFEM<sup>®</sup>**  
ALÜMİNYUM  
**Tente Profilleri**



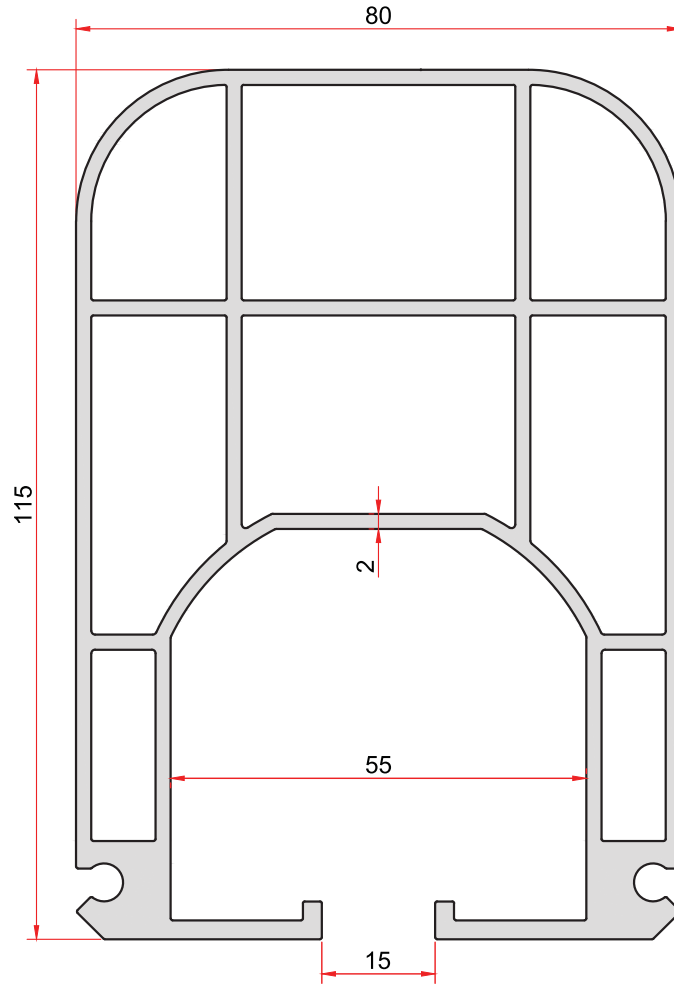

**KOD-CODE** *TEORİK AĞIRLIK*  
*THEORETICAL WEIGHT*  
**97** **4,222 Kg/m**

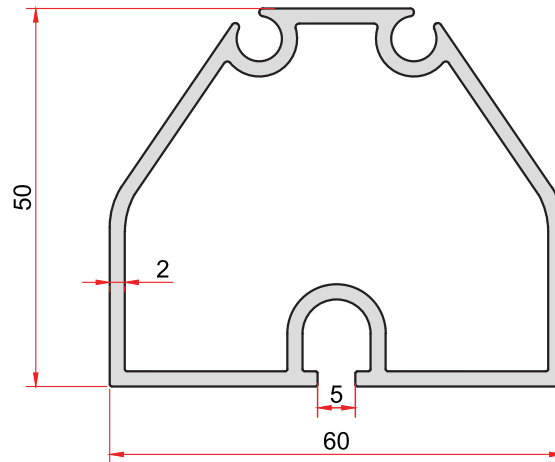

**KOD-CODE** *TEORİK AĞIRLIK*  
*THEORETICAL WEIGHT*  
**98** **1,223 Kg/m**

**ARFEM**<sup>®</sup>  
ALÜMİNYUM

**Soğutma Profilleri**

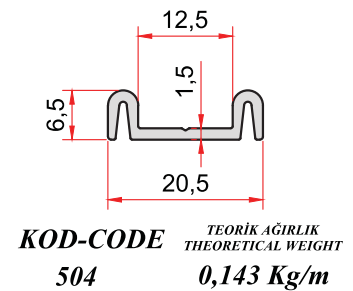
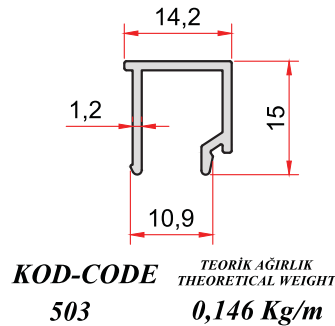
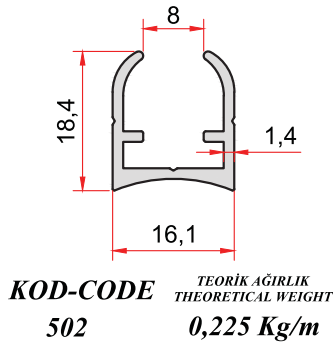
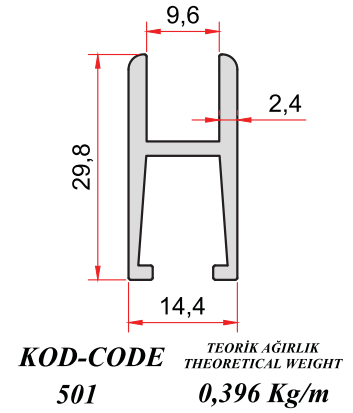
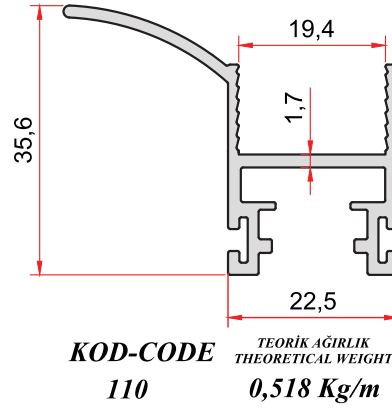
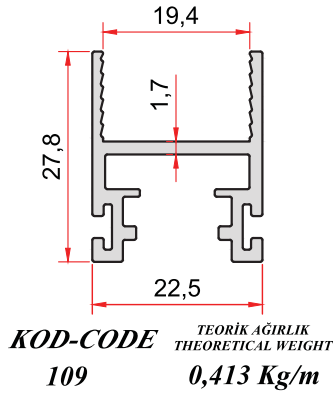
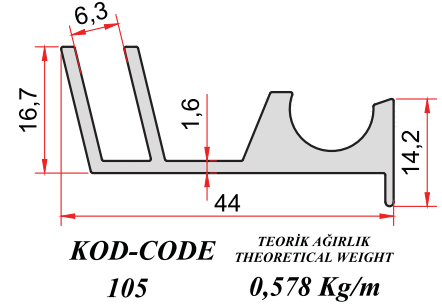
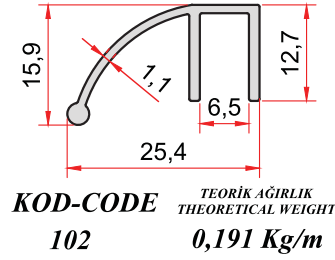
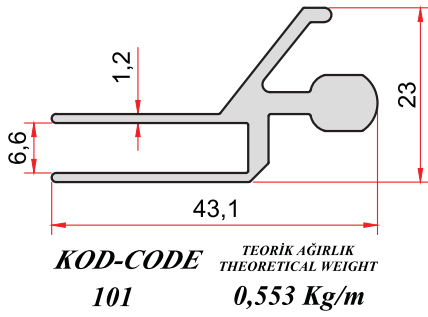
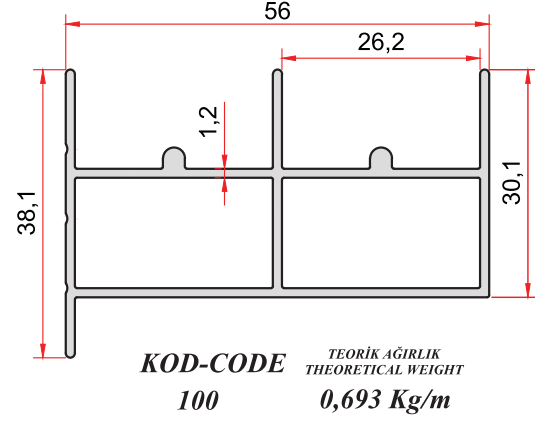
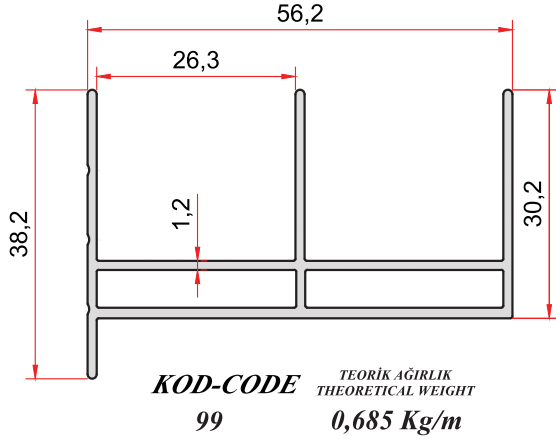



**ARFEM<sup>®</sup>**  
**ALÜMİNYUM**  
**Asansör Profilleri**

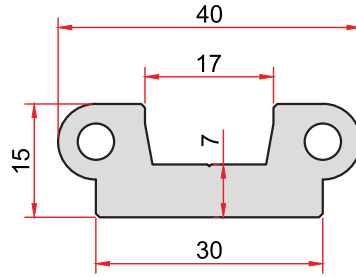

**KOD-CODE**      **TEORİK AĞIRLIK**  
**6501**            **THEORETICAL WEIGHT**  
                         **0,975 Kg/m**

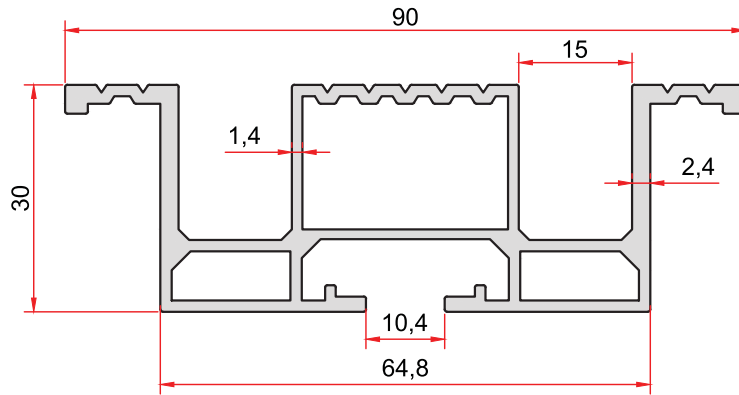

**KOD-CODE**      **TEORİK AĞIRLIK**  
**6502**            **THEORETICAL WEIGHT**  
                         **1,368 Kg/m**



The image shows a modern office environment with glass partitions. The background is a light blue-tinted photograph of an office with desks, chairs, and glass walls. The text is overlaid in the center in a bold, blue, sans-serif font. The word 'ARFEM' is the largest, followed by 'ALÜMİNYUM' and 'Ofis Bölme Profilleri' in a slightly smaller font.

**ARFEM<sup>®</sup>**  
**ALÜMİNYUM**  
**Ofis Bölme Profilleri**

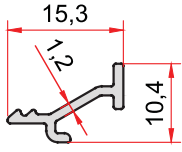

**KOD-CODE** *TEORİK AĞIRLIK*  
*THEORETICAL WEIGHT*  
**AO-1031-12** **0,084 Kg/m**

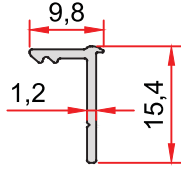

**KOD-CODE** *TEORİK AĞIRLIK*  
*THEORETICAL WEIGHT*  
**AO-1032-13** **0,078 Kg/m**

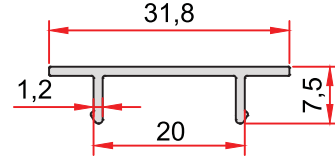

**KOD-CODE** *TEORİK AĞIRLIK*  
*THEORETICAL WEIGHT*  
**AO-1041-12** **0,145 Kg/m**

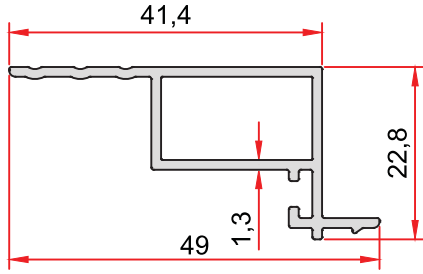

**KOD-CODE** *TEORİK AĞIRLIK*  
*THEORETICAL WEIGHT*  
**AO-1021-13** **0,384 Kg/m**

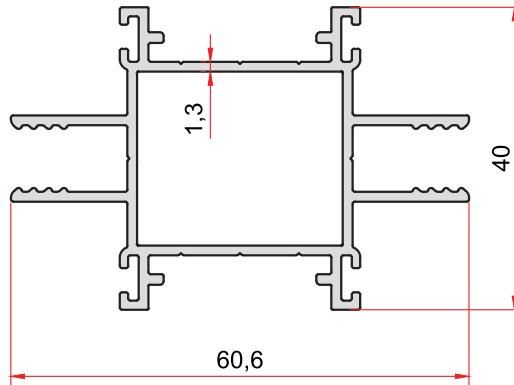

**KOD-CODE** *TEORİK AĞIRLIK*  
*THEORETICAL WEIGHT*  
**AO-1011-13** **0,805 Kg/m**

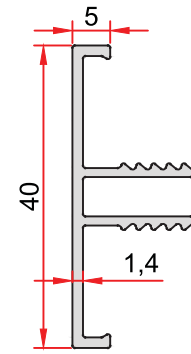

**KOD-CODE** *TEORİK AĞIRLIK*  
*THEORETICAL WEIGHT*  
**AO-1042-14** **0,286 Kg/m**

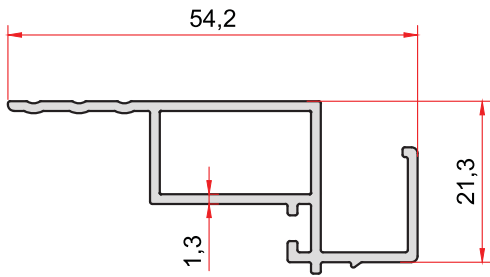

**KOD-CODE** *TEORİK AĞIRLIK*  
*THEORETICAL WEIGHT*  
**AO-1022-13** **0,453 Kg/m**

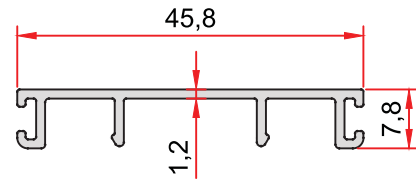

**KOD-CODE** *TEORİK AĞIRLIK*  
*THEORETICAL WEIGHT*  
**AO-1043-12** **0,261 Kg/m**

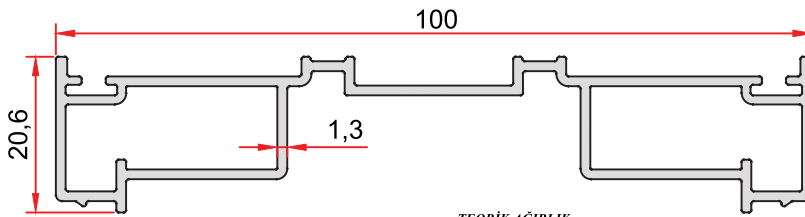

**KOD-CODE** *TEORİK AĞIRLIK*  
*THEORETICAL WEIGHT*  
**AO-1012-13** **0,874 Kg/m**

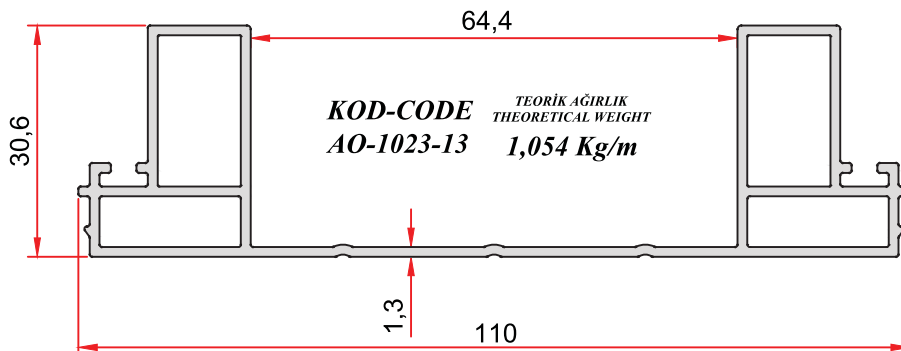

**KOD-CODE** *TEORİK AĞIRLIK*  
*THEORETICAL WEIGHT*  
**AO-1023-13** **1,054 Kg/m**

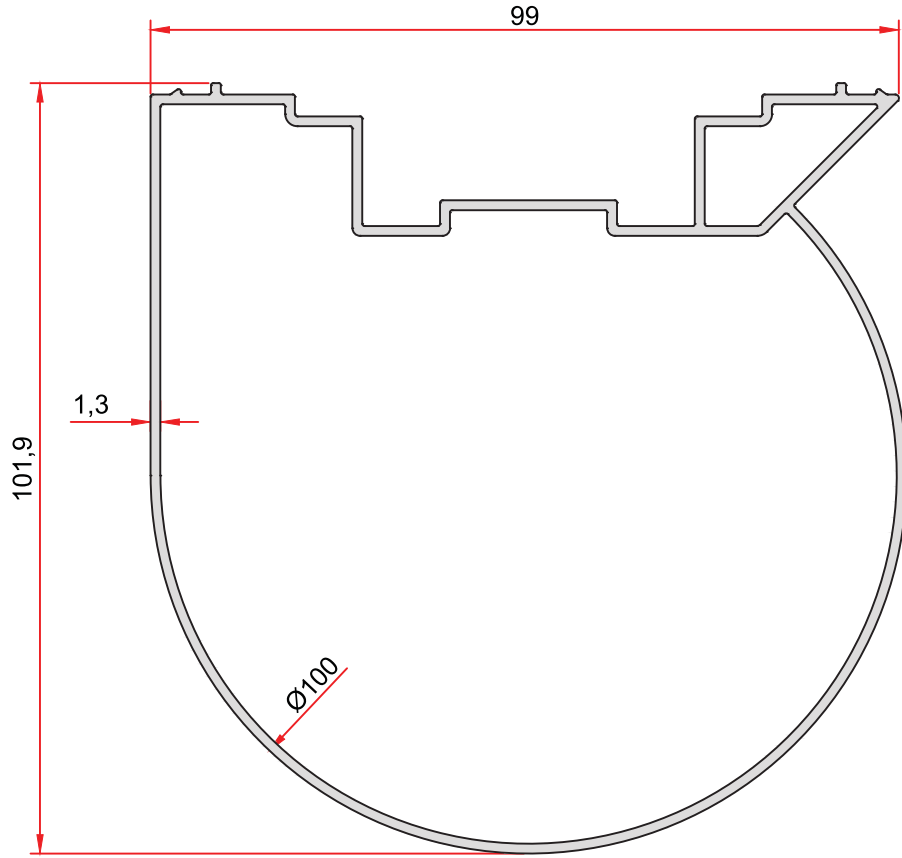

**KOD-CODE**      *TEORİK AĞIRLIK*  
*THEORETICAL WEIGHT*  
**AO-1013-13**    **1,468 Kg/m**

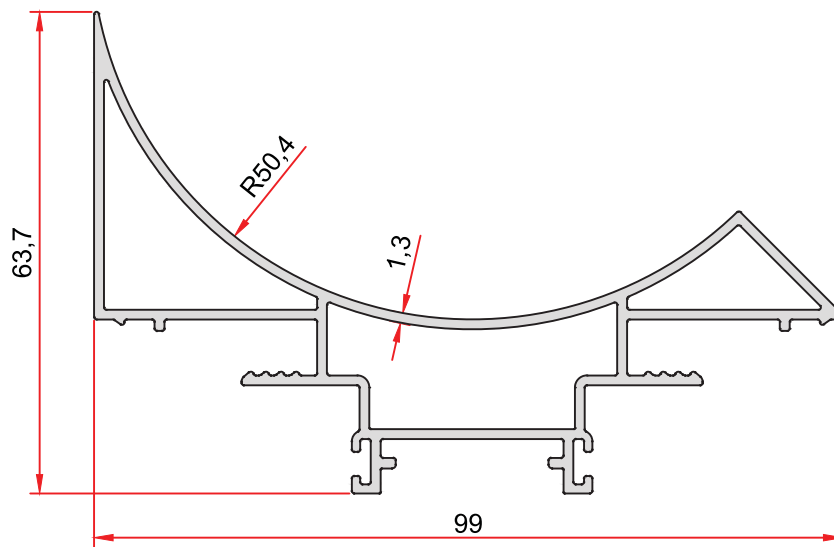

**KOD-CODE**      *TEORİK AĞIRLIK*  
*THEORETICAL WEIGHT*  
**AO-1014-13**    **1,220 Kg/m**

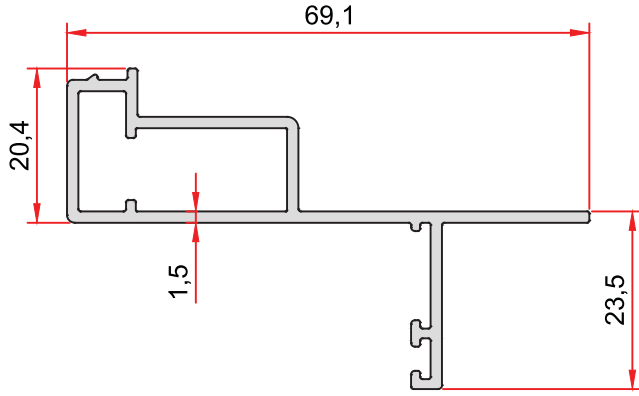

**KOD-CODE** TEORİK AĞIRLIK  
THEORETICAL WEIGHT  
**AO-1024-13** **0,669 Kg/m**

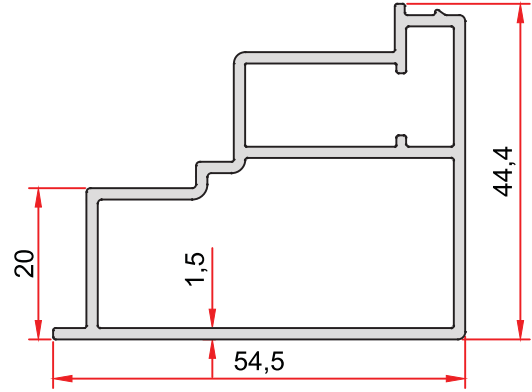

**KOD-CODE** TEORİK AĞIRLIK  
THEORETICAL WEIGHT  
**AO-1025-15** **0,871 Kg/m**

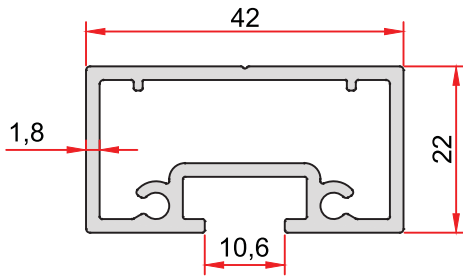

**KOD-CODE** TEORİK AĞIRLIK  
THEORETICAL WEIGHT  
**AO-1027-18** **0,736 Kg/m**

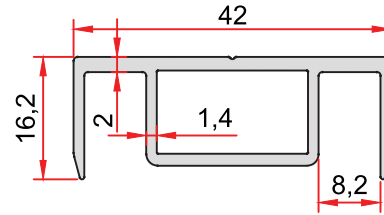

**KOD-CODE** TEORİK AĞIRLIK  
THEORETICAL WEIGHT  
**AO-1028-14** **0,491 Kg/m**

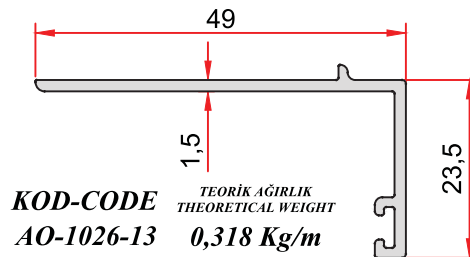

**KOD-CODE** TEORİK AĞIRLIK  
THEORETICAL WEIGHT  
**AO-1026-13** **0,318 Kg/m**

	<b>AC1-02</b>	1 Koli 12 Kg 1 Koli 265 M
	<b>AC2-01</b>	1 Koli 12 Kg 1 Koli 330 M
	<b>AC2-02</b>	1 Koli 10 Kg 1 Koli 210 M
	<b>AC2-03</b>	1 Koli 15 Kg 1 Koli 215 M
	<b>AC3-01</b>	1 Koli 10 Kg 1 Koli 330 M

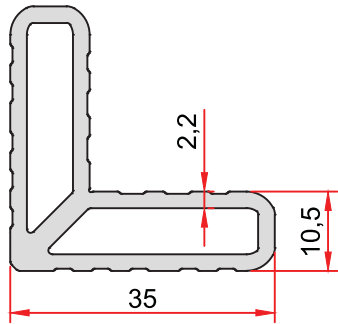

**KOD-CODE** TEORİK AĞIRLIK  
**KT-1105-00** THEORETICAL WEIGHT  
**0,793 Kg/m**

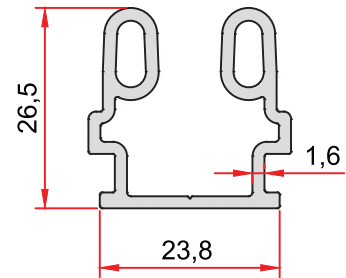

**KOD-CODE** TEORİK AĞIRLIK  
**AO-1051-16** THEORETICAL WEIGHT  
**0,522 Kg/m**

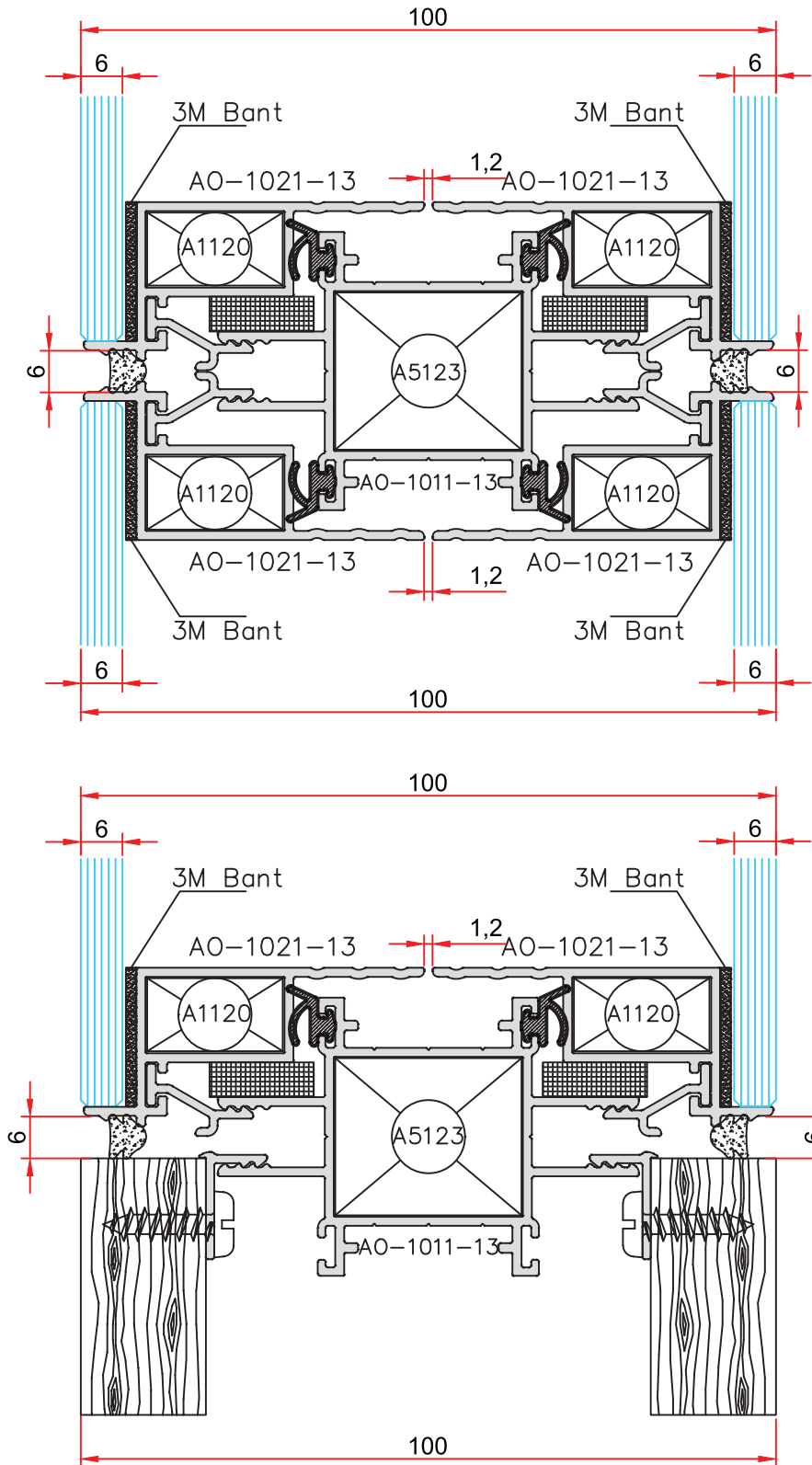

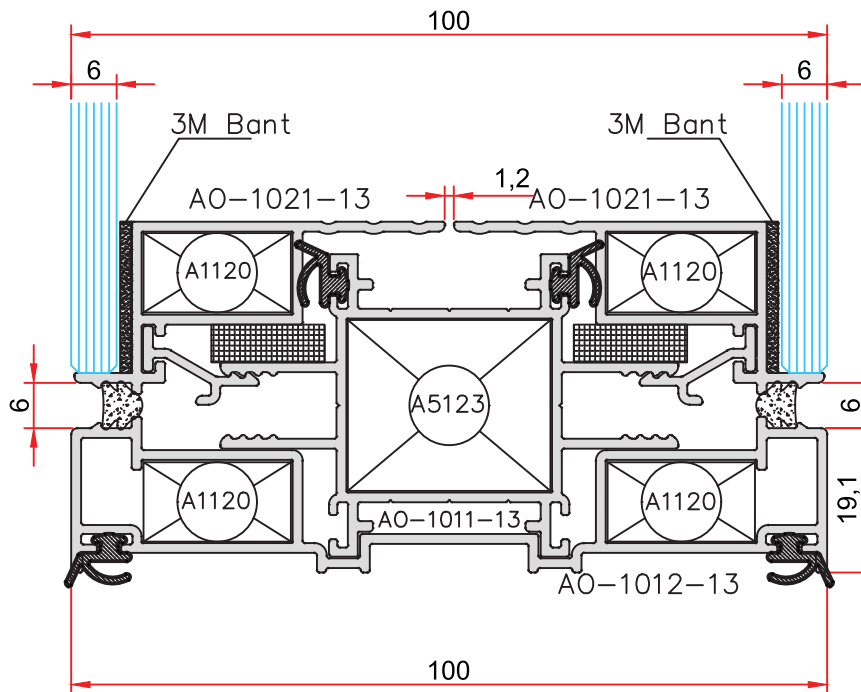
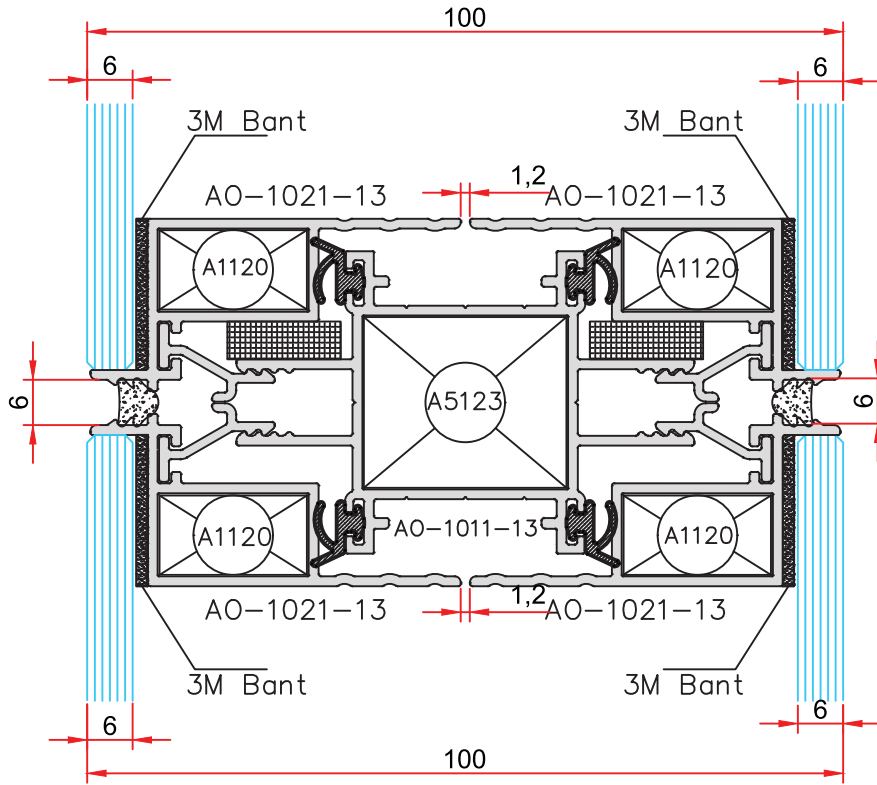

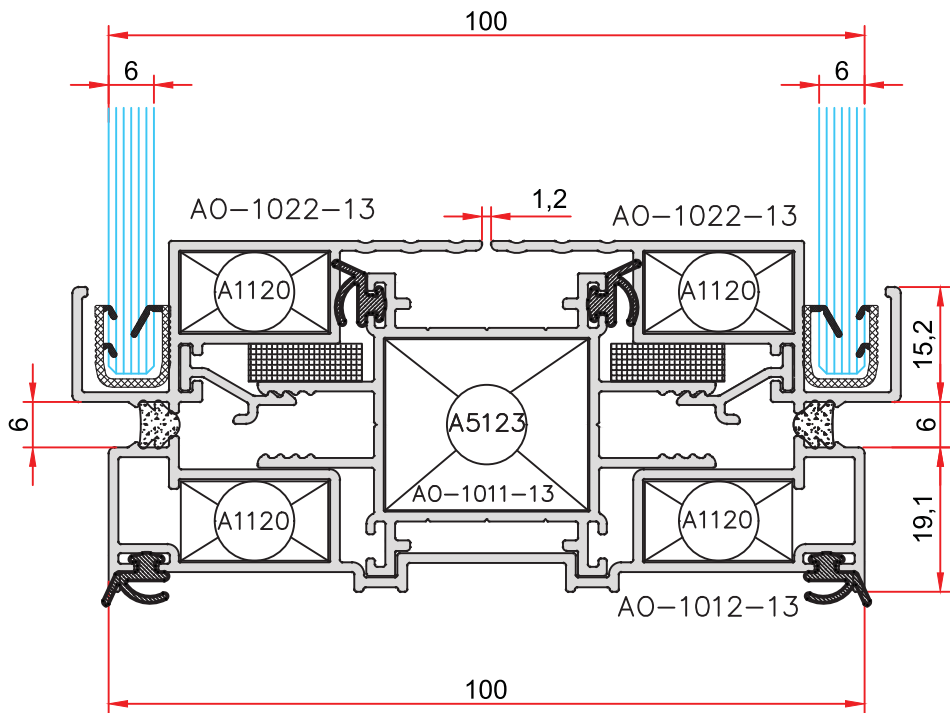
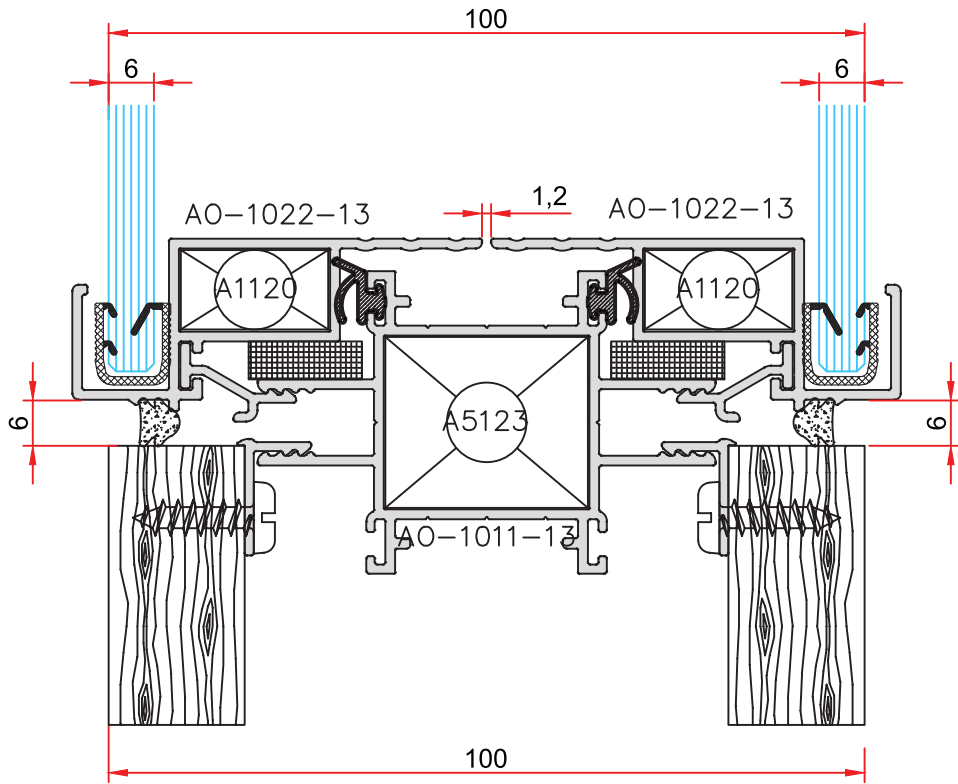



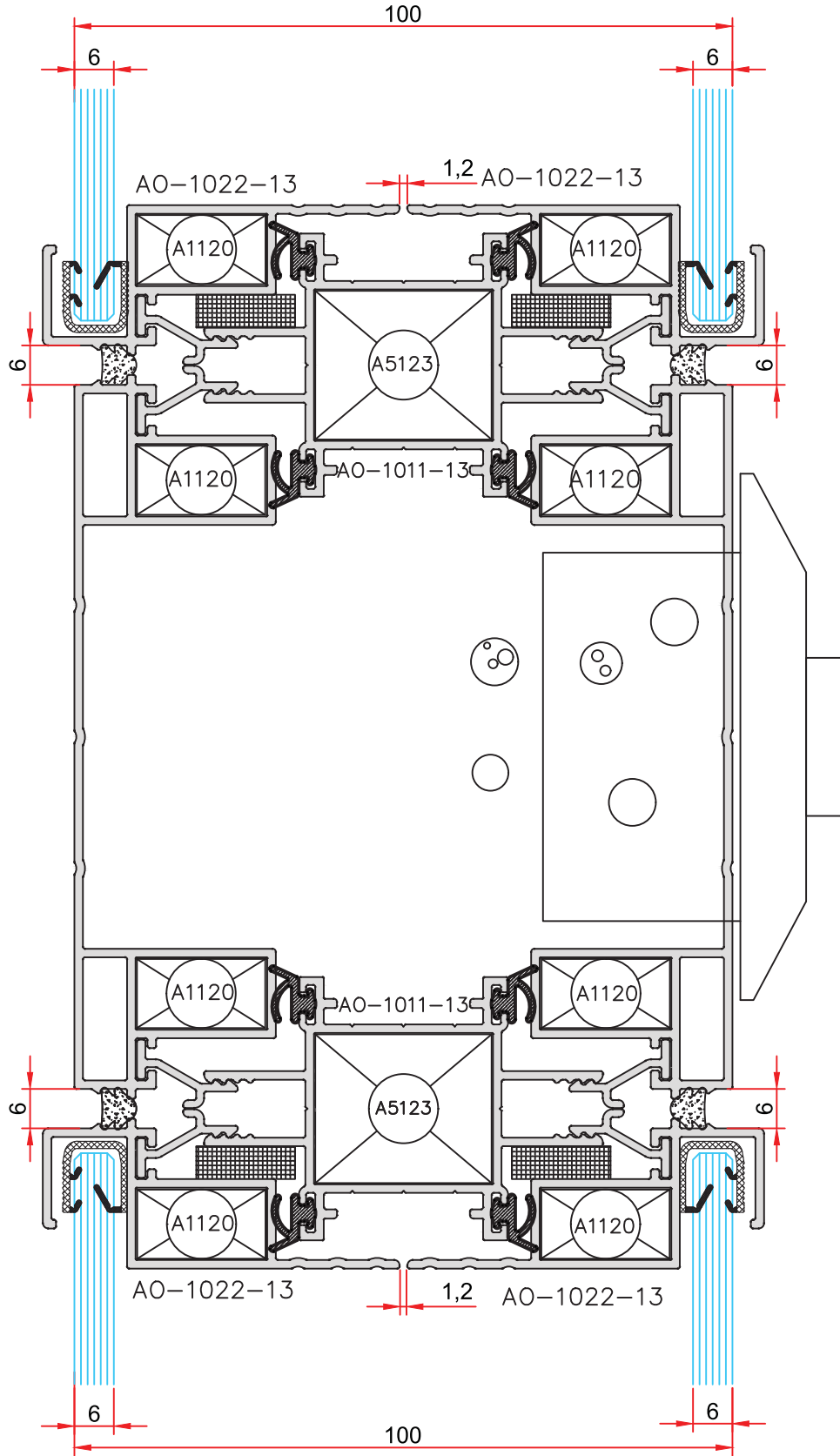

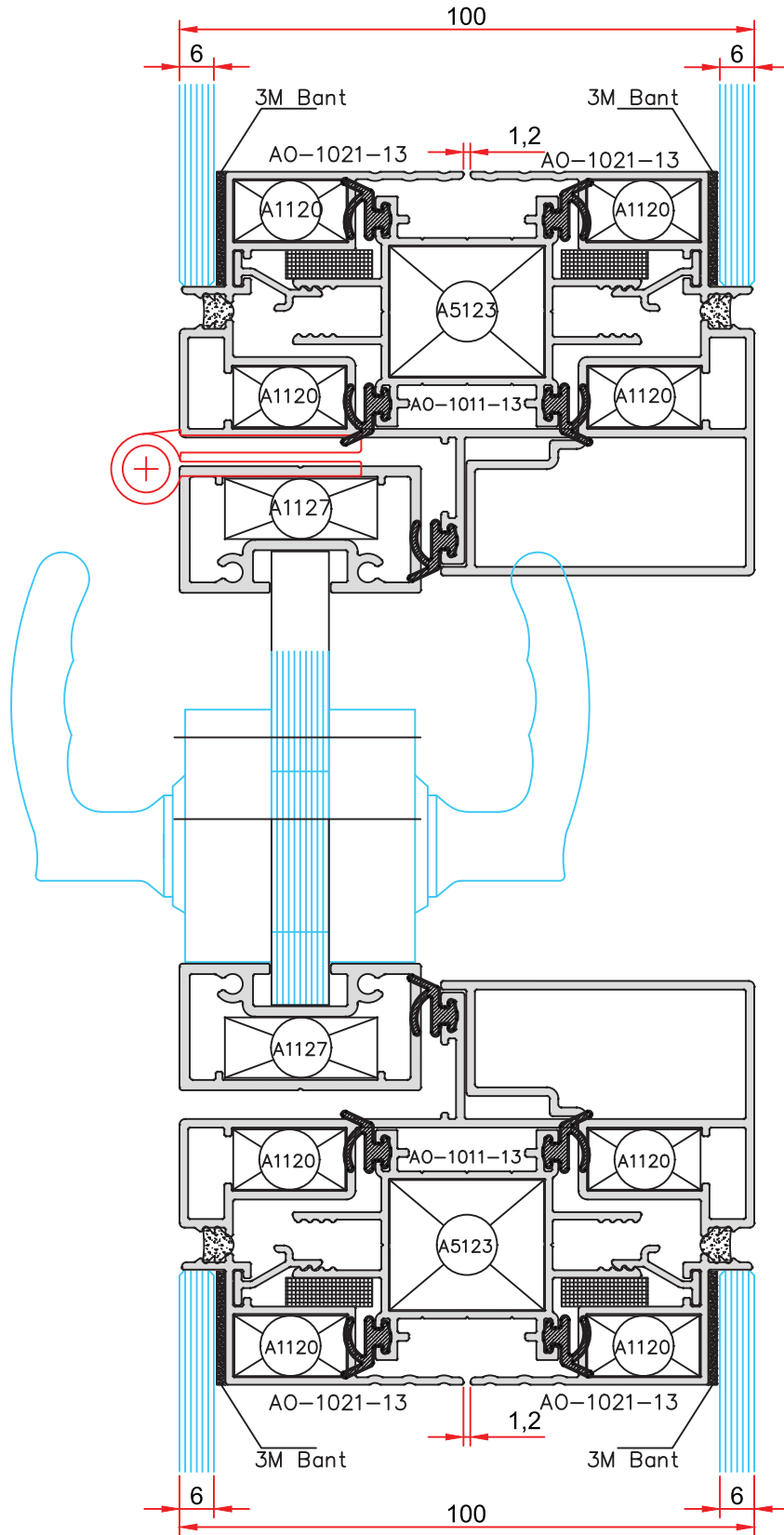

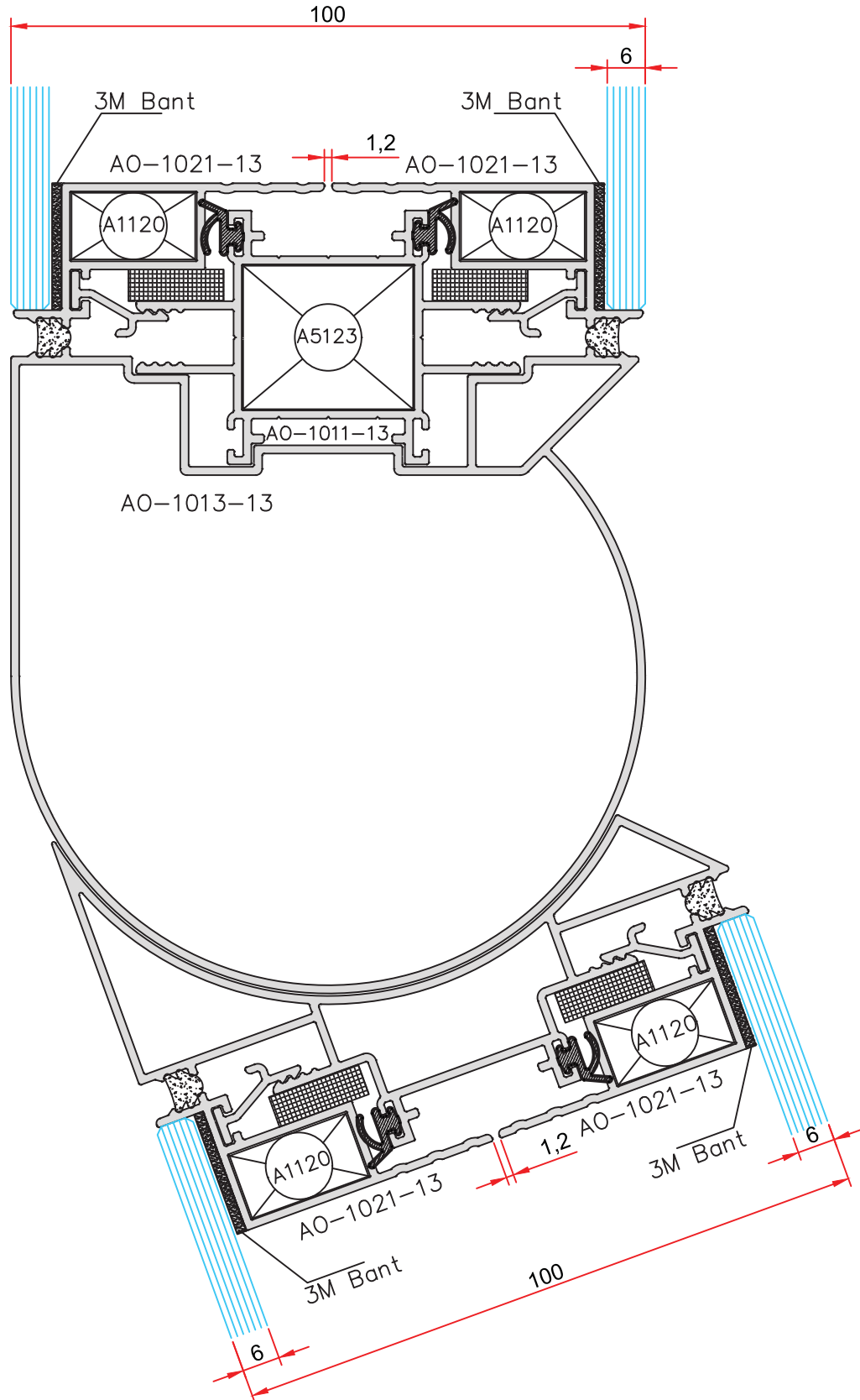

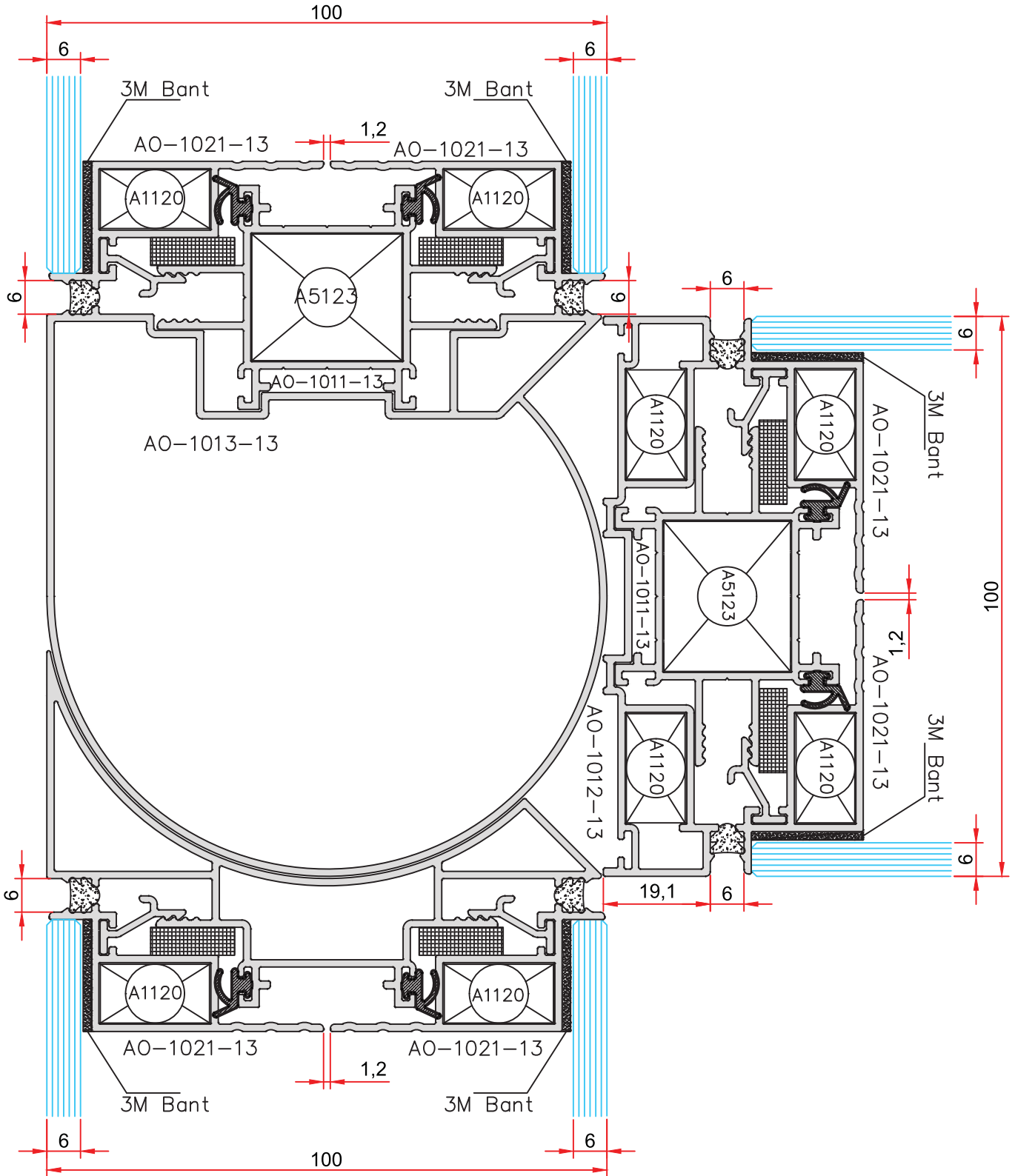

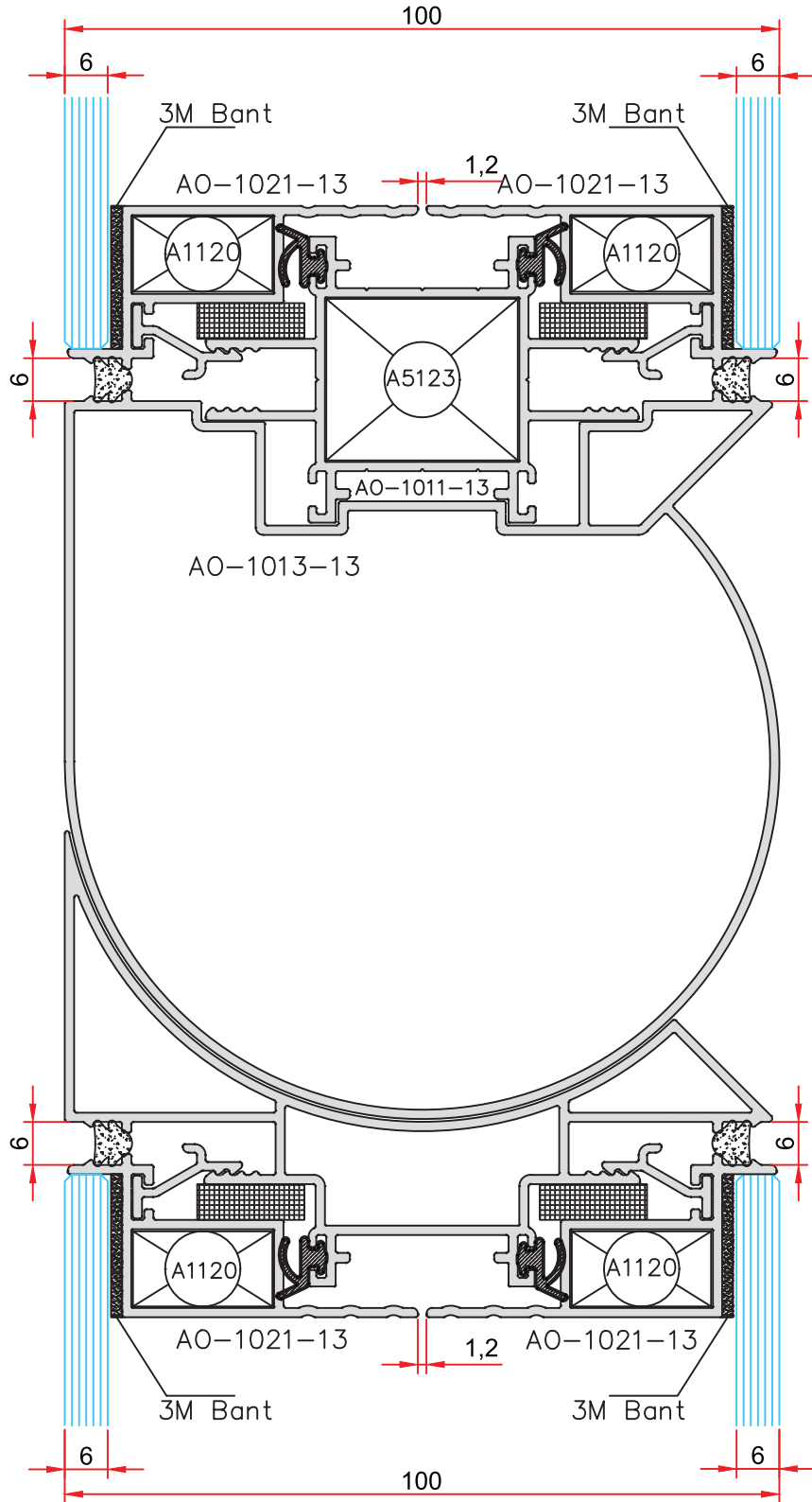

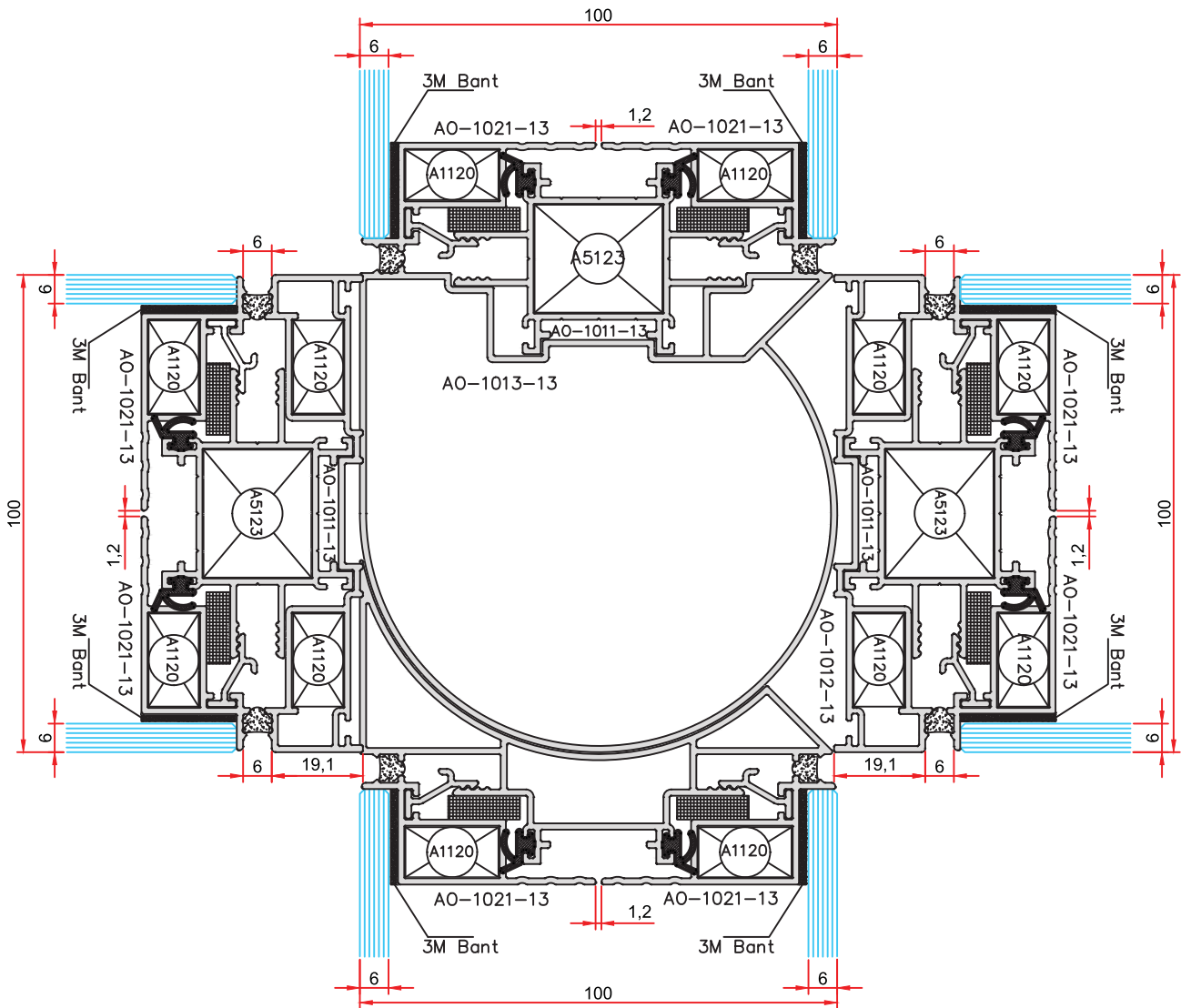



# ARFEM®

## ALÜMİNYUM

Diyarbakır' dan  
Dünya' ya Üretiyoruz

# ARFEM®

## ALÜMİNYUM

- 📍 Yayraş Mah. Organize Sanayi 15. Cad. No:7/1 Yenişehir/DİYARBAKIR  
☎ +90 412 345 01 12 - 13  
☎ +90 412 345 01 09  
✉ info@arfemaluminyum.com.tr  
🌐 www.arfemaluminyum.com.tr

